

कार्यालय नगर निगम, देहरादून।



ई-निविदा सूचना

नगर निगम देहरादून द्वारा राज्य अथवा केन्द्र सरकार के शासकीय/अर्द्धशासकीय विभागों/निगमों में वर्ष 2023-24 हेतु पंजीकृत ठेकेदार/फर्मों को नगर निगम देहरादून क्षेत्रान्तर्गत निम्नांकित निर्माण कार्य की निविदा टू-बिड सिस्टम के तहत ई-टेंडरिंग के माध्यम से ऑनलाईन वेबसाइट <http://www.uktenders.gov.in> पर दिनांक 12.06.2023 तक आमंत्रित की जाती है। सम्बन्धित कार्य में दक्ष फर्मों को इस हेतु प्राथमिकता दी जायेगी। निम्नलिखित कार्य की तकनीकी बिड में अर्ह पाये गये निविदादाताओं की वित्तीय बिड खोली जायेगी। उक्त कार्य की निविदा दि० 20.05.2023 को पूर्वाह्न 11.00 बजे से दि० 12.06.2023 को अपराह्न 4.00 बजे तक ऑनलाईन डाउनलोडिंग/अपलोडिंग के लिए उक्त वेबसाइट पर उपलब्ध होगी। शुद्धि पत्र ऑनलाईन वेबसाइट <http://www.uktenders.gov.in> पर देखी जा सकती है।

नि० सं०	कार्य का नाम	आंगणन राशि (रु० लाख में)	धरोहर राशि (रु० लाख में)	निविदा शुल्क (वाणिज्य कर सहित)	अवधि
1	वार्ड न०-60, आई०टी० पार्क रोड में पार्क का विकास कार्य	113.87	2.28	5000+18%GST	9 माह
2	वार्ड न०-53, में लेन न०-8, गणेश विहार में सार्वजनिक पार्क का विकास कार्य	91.73	1.84	5000+18%GST	9 माह
3	वार्ड न०-33, यमुना कालोनी में पार्क का निर्माण।	167.89	3.36	5000+18%GST	9 माह
4	वार्ड न०-56 ए० ब्लॉक नेहरू कालोनी में सार्वजनिक पार्क का विकास कार्य	88.37	1.77	5000+18%GST	9 माह
5	वार्ड-58 कंदारपुरम में योगा पार्क का निर्माण	499.11	10.00	5000+18%GST	9 माह
6	वार्ड-88 महुवाला में मछली तालाब का रख-रखाव, बनीकरण व वॉकिंग ट्रैक का निर्माण	165.89	3.32	5000+18%GST	9 माह

निविदा धनराशि तथा धरोहर धनराशि की एफ०डी०आर० वित्त नियंत्रक, नगर निगम देहरादून के नाम से प्लेज करनी होगी। निविदा प्रपत्र एवं शर्त तथा तत्सम्बन्धित जानकारी नगर निगम देहरादून की वेबसाइट [www.nagarnigamdehradun.com](http://www.nagarnigamdehradun.com) में अवलोकन एवं प्राप्त की जा सकती है। किसी भी अथवा समस्त निविदाओं को बिना कारण बताये निरस्त करने का पूर्ण अधिकार नगर आयुक्त, नगर निगम देहरादून के पास सुरक्षित होगा।

पत्रांक - 27... / सा०नि०वि० / न०नि० / दे०दून / 23-24

नगर आयुक्त, नगर निगम, देहरादून।  
दिनांक: 18.05.23

प्रतिलिपि:-

1. मा० महापौर महोदय को सूचनार्थ प्रेषित।
2. जिलाधिकारी देहरादून को इस अनुरोध के साथ प्रेषित कि अपने अधीनस्थ विभागों के नोटिस बोर्ड पर चरप्पा करने हेतु निर्देशित करने का कष्ट करें।
3. सम्पादक पाईनियर/हिन्दुस्तान को इस अनुरोध के साथ प्रेषित कि उक्त निविदा सूचना को न्यूनतम क्षेत्रफल में आगामी देहरादून संस्करण में पूर्व में निर्धारित दरों पर छूट देते हुए प्रकाशित कर बिल एवं समाचार की तीन प्रतियां निःशुल्क बिल भुगतान हेतु नगर निगम को उपलब्ध कराने का कष्ट करें।
4. आई०टी० ऑफिसर को इस निर्देश के साथ प्रेषित कि उपरोक्त कार्य की निविदा संबंधित समस्त विवरण नगर निगम की वेबसाइट [www.nagarnigamdehradun.com](http://www.nagarnigamdehradun.com) पर अपलोड करें।
5. नोटिस बोर्ड, नगर निगम देहरादून पर चरप्पा करने हेतु।

अधिशारी, नगर निगम, देहरादून।

# **NATIONAL COMPETITIVE BIDDING**

**E-PROCUREMENT OF  
Civil/Electrical/  
& Allied works under Development of Community Park at  
Lane no.:-08, Ganesh Vihar, Ward no.:-53, Dehradun**



दूरभाष-0135&2655620, 265352, 2658204 फ़ैक्स-0135&2651061  
वेबसाइट-www.nagarnigamdehradun.com  
ई-मेल:[nagar\\_nigam2008@yahoo.com](mailto:nagar_nigam2008@yahoo.com),[nagarnigam.ddn@gmail.com](mailto:nagarnigam.ddn@gmail.com)  
टोल फ्री नं० - 1800-180-4153, कन्ट्रोल रूम - 1800-180-4206

**Technical Bid**

# **STANDARD BIDDING DOCUMENT**

## **INDEX**

<b>S. No.</b>	<b>Volume</b>	<b>Particulars</b>	<b>Page No.</b>
		<b>Technical Bid</b>	
1	I	<u>e</u> -Procurement Notice	03
1.	I	Invitation for Bid (IFB)	04
2.	I	Section 1 – Instruction to Bidder (ITB)	06
3.	I	Section 2 – Qualification Information (QI)	28
4.	I	Section 3 – Conditions of Contract (CC)	41
5.	I	Section 4 – Contract Data (CD)	75
6.	I	Section 5 – Technical Specification	78
7.	I	Section 7 – Security and Other Forms (SOF)	369
8.	I	Section 8 – Drawings	378
		<b>Financial/ Price Bid</b>	
9	II	Section 6 – Bill of Quantity (BOQ)	And a separate file

## कार्यालय नगर निगम देहरादून

दूरभाष-0135&2655620, 265352, 2658204 फैक्स-0135&2651061

वेबसाइट-www.nagarnigamdehradun.com

ईमेल:nagar\_nigam2008@yahoo.com,nagarnigam.ddn@gmail.com

टोल फ्री नं० - 1800-180-4153 कन्ट्रोल रूम - 1800-180-4206

Ref: 727/PWD/NND/2023-2024

Dated: 18-05-23

### E-Tendering

On behalf of Nagar Nigam Dehradun Uttarakhand, E-Tenders are invited by Municipal Commissioner, Nagar Nigam Dehradun from the Contractors registered as Class "B" or above Category with central govt./ state govt./ other organisation. Construction Bids must be submitted online on the website [www.uktenders.gov.in](http://www.uktenders.gov.in) on or before 12/06/2023, 4:00 PM. A complete set of bidding documents in English may be downloaded by contractors from the website [www.uktenders.gov.in](http://www.uktenders.gov.in) which will be available on the website from 20/05/2023 to 12/06/2023. Corrigendum/Addendum regarding this advertisement as and when required will be uploaded on the website [www.uktenders.gov.in](http://www.uktenders.gov.in).

S. No.	District	Detail of Work	Estimated Cost	Earnest Money	Completion Period	Cost of Tender Document
			(Rs. In Lac)	(Rs. In Lac)	(In months)	(In Rs.)
1.	Dehradun	Development of Community Park at Lane no.-08, Ganesh Vihar, Ward no.-53, Dehradun	91.73	1.84	9 months	5000.00+ 18% GST

The important dates are given below for submission of online bids.

1	Date of Publication	19/05/2023
2	Document Download Start Date	20/05/2023
3	Document Download End Date	12/06/2023
4	Pre Bid Meeting Date	27/05/2023
5	Bid Submission End Date (online)	12/06/2023
6	Date of Technical Bid opening	20/06/2023
6	Date of submission of hard copy to Tender document	15/06/2023

Executive Engineer  
अभिशांत  
नगर निगम, देहरादून

Ref:

Dated:

**NATIONAL COMPETITIVE BIDDING**  
**INVITATION FOR BID (IFB)**

1. On behalf of Nagar Nigam Dehradun, E-Tenders are invited by Municipal Commissioner, Nagar Nigam Dehradun from the Contractors registered as Class "B" or above Category with central govt./ state govt./ other organisation for construction of work given in the following table: -

S. No	Name of work	Estimated Cost (Rs. In lac)	Bid Security/ Earnest Money Deposit (Rs. In lac)	Cost of Tender Form	Time of completion
1.	Development of Community Park at Lane no.-08, Ganesh Vihar, Ward no.-53, Dehradun	91.73	1.84	5000.00+18% GST	9 months

2. **Availability of Bid Document and mode of submission:** The bid document is available online and bid should be submitted on line on website [www.uktenders.gov.in](http://www.uktenders.gov.in). The bidder would be required to register in the web-site which is free of cost. For submission of bids, the bidder is required to have Digital Signature Certificate (DSC) from one of the authorized Certifying Authorities (CA). The tender document should be accompanied with non refundable tender document fee of Rs. 5000.00 + 18% GST as applicable. in form of Demand Draft of any Nationalized/ Scheduled bank, payable at Dehradun, in favour of Finance Controller, Nagar Nigam Dehradun. Digital signature is mandatory to participate in the e-tendering. Bidders already possessing the digital signature issued from authorized CAs can use the same in this tender.
3. Nagar Nigam Dehradun will not be responsible for the postal delay or delay in online submission, if any, in delivery of the documents or non receipt of the same.
4. Bids must be accompanied by bid security (Earnest Money Deposit) of the amount specified for the work in the table above, payable at Dehradun and drawn in favor of Finance Controller, Nagar Nigam Dehradun. Bid security will have to be in the form of demand draft or Bid Securing Declaration form only.
5. Only online submission of bids is permitted, therefore; bids must be submitted online on website [www.uktenders.gov.in](http://www.uktenders.gov.in). The technical qualification part of the bid will be opened online on 20/06/2023 at 3:00 PM by the authorized officers. If the office happens to be closed on the date of opening of the bids as specified, the bids will be opened on the next working day on dates at the same time and venue.
6. The Balance Bid Capacity of the tenders shall be calculated on the basis of the formula mentioned in the tender document.

7. The tenderers quoting rates less than estimated rates Additional Performance Security shall be worked out as follows:-
- No Additional Performance Security for item rates up to 5% below the estimated item rate.
  - An Additional Performance Security of 10% of the estimated cost of items, for item rates from 5% to 15 % below the estimated rate.
  - An Additional Performance Security of 15% of the estimated cost of items, for item rates more than 15% below the estimated rate.
8. Date of Downloading of Bidding Document : 20/05/2023
9. Place of Pre-Bid Meeting : Nagar Nigam Dehradun.
- Time and Date of Pre-Bid Meeting : 27/05/2023, 11:00 AM,
10. Date/ Time for receipt of bids through e-tendering: 12/06/2023, 4:00 PM
11. Time and Date of Opening Technical Bid : 20/06/2023, 4:00 PM
12. Last date of submission of Hard Copy of Tender Document: 15/06/2023
13. Time and Date of Opening Financial (Price) Bids: 21/06/2023, 2:00 PM,
14. Place of Opening of Bids : Nagar Nigam Dehradun
15. Response of Pre-Bid Queries/Common Set of Deviation will be uploaded only on website ([www.uktenders.gov.in](http://www.uktenders.gov.in)) within three working days after the pre-bid meeting.
16. The Bidder who downloads the tender document should intimate the undersigned about its downloading, so that undersigned may directly intimate the tenders for any alteration/addition/addendum in the tender document (Besides issuing Corrigendum). Bidder shall be responsible for downloading all the corrigendum/ addendums when uploaded by Nagar Nigam Dehradun.
17. The Municipal Commissioner reserves the right to reject/cancel any or all the tenders without assigning any reasons whatsoever.
18. The downloaded tender document will be considered legally valid for participation in the tender process, if and only if accompanied by document fee as per advertisement.
19. Conditional & Incomplete Tenders will be summarily rejected.
20. Partnership deed is mandatory in case of partnership firm.
21. Electricity and water supply for the construction work etc. shall be arranged by the contractor at his own cost. The water should be suitable for construction purpose as per latest IS code.
22. Other details can be seen in the bidding documents. The Employer shall not be held liable for any delays due to system failure beyond its control. Even though the system will attempt to notify the bidders of any bid updates, the Employer shall not be liable for any information not received by the bidder. It is the bidders' responsibility to verify the website '[www.uktenders.gov.in](http://www.uktenders.gov.in)' for the latest information related to the tender.

Executive Engineer  
नगर निगम, देहरादून

# **SECTION 1**

## **INSTRUCTION TO BIDDERS (ITB)**

## SECTION 1: INSTRUCTION TO BIDDERS (ITB)

### TABLE OF CLAUSES

<b>A.</b>	<b>GENERAL</b>	<b>Page No</b>
1	Scope of Bid	8
2	Source of Funds	8
3	Eligible Bidders	8
4	Qualification of the Bidder	8-12
5	One Bid per Bidder	12
6	Cost of Bidding	12
7	Site Visit	12
<b>B.</b>	<b>BIDDING DOCUMENTS</b>	
8	Content of Bidding Documents	13
9	Clarification of Bidding Documents & Pre bid meeting	13-14
10	Amendment of Bidding Documents	14
<b>C.</b>	<b>PREPARATION OF BIDS</b>	
11	Language of Bid	15
12	Documents Comprising the Bid	15
13	Bid Prices	15
14	Currencies of Bid and Payment	15
15	Bid Validity	15
16	Bid Security	15-16
17	Alternative Proposals by Bidders	16
<b>D.</b>	<b>ONLINE SUBMISSION OF BIDS</b>	
18	Bidding Through E- Tendering & Electronic Submission of Bid	17
19	Deadline for Submission of Bids	17
20	Late Bids	18
21	Modification and Withdrawal of Bids	18
<b>E.</b>	<b>BID OPENING AND EVALUATION</b>	
22	Bid Opening	19
23	Process to be Confidential	19
24	Clarification of Financial Bids & contacting the employer	19
25	Examination of Bids and Determination of Responsiveness	20
26	Correction of Arithmetic errors	20
27	Evaluation and Comparison of Financial Bids	20
<b>F.</b>	<b>AWARD OF CONTRACT</b>	
28	Award Criteria	21
29	Employer's Right to Accept any Bid and to Reject any or all Bids	21
30	Notification of Award and Signing of Agreement.	22
31	Performance Security	22
32	Advance payment and security	23
33	Dispute Review Expert/ Adjudicator	23
34	Corrupt or Fraudulent Practices	23



## **A. GENERAL**

### **1. Scope of Bid**

- 1.1. The Employer [Municipal Commissioner, Nagar Nigam Dehradun] invites bids in electronic tendering system for the construction of works (as defined in these documents and referred to as “the works”) detailed in the table given in Invitation for Bid (IFB).
- 1.2. The successful bidder will be expected to complete the works by the intended completion date specified in the Contract data.
- 1.3. Throughout these bidding documents, the terms bid and tender and their derivatives (bidder/tenders, bid/tender, bidding tendering etc.) are synonymous.
- 1.4. The term “in writing” means communicated in written form and delivered against receipt.
- 1.5. Except where the context requires otherwise, words indicating the singular also include the plural and words indicating the plural also include the singular.

### **2. Source of Funds**

- 2.1. The expenditure on this project will be met from the Govt. of India /Uttarakhand/Nagar Nigam Dehradun.

### **3. Eligible Bidders**

- 3.1. This invitation for bids is open to all eligible bidders meeting the eligibility criteria as defined in clause no 4 (Qualification of the Bidder).
- 3.2. All bidders shall provide in Section-2, Qualification Information and undertaking for Non-Association with Consultant. A firm that has been engaged by the Employer to provide consulting services for the preparation or supervision of the works, and any of its affiliates, shall not be eligible to bid.
- 3.3. Government owned enterprise may only participate if they are legally and financially autonomous, operated under commercial law and are not a dependent agency of the Employer and fulfill all the requirements as described in eligible criteria for this tender.

### **4. Qualification of the Bidder**

- 4.1. All bidders -shall provide Qualification Information as given in Section-2 and Forms of Bid as given in Section-2.
- 4.2. All bidders shall include the following information and documents with their bids in section-2:

- (a) Original demand draft towards the cost of bid document,
- (b) Original bid security in approved form,
- (c) Original affidavit regarding correctness of information furnished with bid document as per provisions of bid document,
- (d) Experience and turnover certificate as per clause 4.4 (A) must also be submitted
- (e) Registration/Empanelment Certificate.
- (f) Electrical License
- (g) General Information as per S. No. 1.1 of Qualification Information. Copies of original documents defining the constitution or legal status, place of registration and principal place of business written power of attorney of the signatory of the Bid to commit the Bidder;
- (h) Total value of related Engineering construction work (Civil/Electrical/Water Supply/Sanitary/Fire Fighting similar works) performed in the last five years;
- (i) Original affidavit regarding, bid validity, correctness of information furnished with bid document, non abundant/blacklisted of firm, non association with PMC/Consultant for this work if applicable, undertaking that bidder would be able to invest a minimum of cost upto 20% of the contract value of work, during implementation of contract, adhering to Special Conditions of Contracts for implementation of measures for protection of environment and duly signed on Rs. 100/- revenue stamp paper and revenue ticket of Rs. 1/- affixed thereon, **(Format Given in Section-2)**
- (j) Evidence of access to or availability of credit facilities (minimum 20% of estimated cost) certified by the bankers; **(Format Given in Section-2)**
- (k) Power of attorney, if applicable.
- (l) PAN Card and GSTIN;
- (m) Form of bid **(Format Given in Section-2)**
- (n) Information regarding bid capacity.
- (o) Annual Turnover Certificate from chartered Accountant for last five financial years forms for the construction works in each financial year. (Clause 4.4 of ITB).
- (p) Balance sheet showing profit and loss of last five financial years (Audited Report).
- (q) Key personnel on requisite format including their self attested bio data, qualification certificates and self declaration form on working in participating firm/organization on 10 rs. Stamp paper.
- (r) Detail of Equipments/Machineries owned or possessed/brought on hire on requisite format. (Clause 4.5 of ITB)
- (s) Undertaking for pending litigation/Arbitration if any.
- (t) Proposals for subcontracting components of work (for each, the qualifications and experience of the identified sub-contractor in the relevant field should be annexed);
- (u) The proposed methodology and programme of construction, backed with equipment planning and deployment, duly supported with broad calculations and quality control procedures proposed to be adopted. Justifying their capability of execution and completion of the work as per technical specifications within the stipulated period of completion as per milestones;
- (v) The bidder shall provide manufacturer's undertaking and authenticity of the products and part codes provided / supplied for the work as mentioned under the technical specification of the products and work shall be carried out by the authorized distributor / dealer / system integrator of the OEM (Original

Equipment manufacturer) only. Manufacturer's authorization certificate needs to be provided in this regard. (As indicated in Appendix)

Pre delivery factory inspection of the materials and equipments is required prior to dispatch of the materials/equipments. Satisfactory document showing genuineness of material shall be produced by supplier as factory inspection is not feasible/ economical considering the small value of items to be imported from abroad. Cost for two persons for factory inspection shall be borne by the contractor. The contractor shall include all charges in their prices for samples, testing & inspection of materials at the works of manufacturer. The contractor's rates shall be deemed to include all such expenditures & cost. The contractor shall also arrange all the test certificates & results & submit to the Engineer in original with the four sets of photo copies along with catalogue & Manuals.

- (u) The Main Contractor shall submit an agreement with electrical contractor who shall give their consent to carry out the work. The electrical contractor shall have 'A' Category licence for electrical works. Both electrical & Fire fighting contractor shall have valid experience as mentioned in appendix to ITB item no. 6

4.3 **(A) To qualify for award of the contract each bidder in its name should have in the last five years as referred to in Appendix.**

i. Achieved minimum annual value of general construction work (as certified by chartered Accountant, and at least 50(fifty) percent of which is from Engineering construction works) carried out in any of the year over last five years, calculated by applying an appropriate multiplier to the projected annual construction expenditure on the subject contract. The turnover will be indexed at the rate as given in Contract Data.

ii. Satisfactorily completed at least one similar work (till publishing date of this RFP) worth 80 % of estimated tender value of Rs. **91.73 Lac**

or,

Atleast two similar works worth 50% each of the estimated tender value of Rs. **91.73 Lac** in the last five years which shall be indexed as below: -

Year	Escalation Factor
2018-2019	1.61
2019-2020	1.46
2020-2021	1.33
2021-2022	1.21
2022-2023	1.1

iii Similar works mean as indicated in Appendix; (Contract Data)

iv Sub Contractor Exp. is in indicated in Appendix; (Contract Data)

- (a) The bidder should submit certificates from an officer the rank not below the Executive Engineer of Govt. or Semi Govt. indicating there in the names of the works completed. Value of works and period during which completed;

- (b) Bidder has to satisfy the eligibility criteria for technical capability competence as well as for financial capacity and organizational resources;
- (c) The experience certificate from any private contractor or private organization and as a sub contractor to prime contractor shall not be considered while evaluating the bid in compliance to the qualifying criteria.

**(B) Each bidder should further demonstrate.**

- (a) Availability of machinery and equipments required as per **Annexure – I**.
- (b) Availability of personnel with adequate experience required as per **Annexure-II**;

**(C) Financial Capabilities.**

The applicant should have: (i) access to, or possess available liquid assets and other financial means (independent of any contractual advance payments) sufficient to meet the construction cash flow requirements for the subject contract, of the certain minimum amount specified; (ii) adequate sources of finance to meet the cash flow requirements of works currently in progress and for future contract commitments; and (iii) financial soundness as established by audited balance sheets and/ or financial statements. Average Annual Financial Turnover of the bidders during the last three years ending 31st March of the previous financial year should be at least 30% of the estimated cost.

- (D)** Bidder should be qualified as indicated in Appendix, proof of certificate of this effect is required to be submitted by the bidders. Bidders should be registered as Class “B” or above Category with central govt./ state govt./ other organisation, proof of certificate of this effect is required to be submitted by the Bidders.

4.4 Sub-Contractors experience and resources shall not be taken into account in determining the bidder’s compliance with the qualifying criteria.

4.5 Bidders who meet the minimum qualification criteria will be qualified only if their available bid capacity is more than the total bid value. The available bid capacity will be calculated as under: -

Escalation Factor (Multiplying factor of evaluating value of work executed year before: -

One – 1.1, Two-1.21, Three -1.33, Four-1.46, Five -1.61

Assessed Available Bid Capacity = (A\*M\*N-B) Where

A= Maximum value of Construction work with or without Electrical works executed in any one year during the last five years (updated to the price level of the year indicated in **Appendix**) taking into account the completed as well as works in progress.

M= Multiplier Factor (Usually 1.5)

N= Number of years prescribed for completion of the works for which bids are invited.

B= Value (updated to the price level of the year indicated in **Appendix**) of existing commitments and on-going works to be completed during the next one).

**Note:-** The statements showing the value of existing commitments and on-going works as well as the stipulated of completion remaining for each of the works listed should be countersigned by the Engineer in charge, not below the rank of an Executive Engineer or equivalent.

- (a) Even though the bidders meet the above qualifying criteria, they are subject to be disqualified if they have:-
- (b) Made misleading or false representations in the forms, statements and attachments submitted in proof of the qualification requirements: and/or.
- (c) Record of poor performance such as abandoning the works, not properly completing the contract, inordinate delays in completion, litigation history, or financial failures, etc. and/or.
- (d) Participated in the previous bidding for the same work and had quoted unreasonably high bid prices and could not furnish justification to the employer.

## **5 One Bid per Bidder**

Each bidder shall submit only one bid for the work. Conditional or alternative bids if submitted will make the bidder non-responsive.

## **6 Cost of Bidding**

- 6.1 The bidder shall bear all costs associated with the preparation and submission of his Bid, and the Employer will in no case be responsible and liable for those costs.

## **7. Site Visit**

- 7.1 The Bidder, at the Bidder's own responsibility and risk is encouraged to visit and examine the site of works and its surroundings and obtain all information that may be necessary for preparing the Bid and entering into a contract for construction of the works. The cost of visiting the site shall be at the Bidder's own expense.

## **B. BIDDING DOCUMENTS**

### **8. Content of Bidding Documents**

8.1 The set of bidding documents comprises the documents listed below and addenda issued in accordance with Clause 11: -

<b>Section</b>	<b>Particulars</b>	<b>Volume No.</b>
	Invitation for Bid	I
1.	Instructions to Bidders	
2.	Qualification Information, Form of Bid and other forms	
3.	Conditions of Contract	
4.	Contract Data	
5.	Technical Specifications	
7.	Securities and other forms	
8.	Drawings	
6.	Bill of Quantities	II

8.2 The bid document is available online on the website [www.uktenders.gov.in](http://www.uktenders.gov.in). The bid document can be downloaded free of cost; however, the bidder is required to submit demand draft towards cost of bid document in favour of the name given in Contract Data Sheet. The bidder is expected to examine carefully all instructions, conditions of contract, contract data, forms, terms, technical specifications, bill of quantities, forms, Annexure and drawings in the Bid Document. Failure to comply with the requirements of the Documents shall be at the bidder's own risk. Pursuant to clause 27 hereof bids which are not substantially responsive to the requirements of the Bid Documents shall be rejected.

### **9. Clarification of Bidding Document, Site Visit, Pre-Bid Meeting**

9.1 A prospective Bidder requiring any clarification of the Bidding Document shall contact the Employer in writing at the Employer's address indicated in the IFB or raise his inquiries during the pre-bid meeting if provided for in accordance with ITB 9.4. The Employer will respond in writing to any request for clarification, provided that such request is received prior to the deadline for submission of bids, within a period given in the IFB. The Employer shall forward copies of its response to all Bidders who have acquired the Bidding Document in accordance with ITB 8.2, including a description of the inquiry but without identifying its source. Should the Employer deem it necessary to amend the Bidding Document as a result of a request for clarification, it shall do so following the procedure under ITB 10

9.2 The Bidder is advised to visit and examine the Site of Works and its surroundings and obtain for itself, on its own risk and responsibility, all information that may be necessary for preparing the bid and entering into a contract for construction of the Works. The costs of

visiting the Site shall be at the Bidder's own expense.

- 9.3 The Bidder and any of its personnel or agents will be granted permission by the Employer to enter upon its premises and lands for the purpose of such visit, but only upon the express condition that the Bidder, its personnel, and agents will release and indemnify the Employer and its personnel and agents from and against all liability in respect thereof, and will be responsible for death or personal injury, loss of or damage to property, and any other loss, damage, costs, and expenses incurred as a result of the inspection.
- 9.4 The Bidder's designated representative is invited to attend a pre-bid meeting, if provided for in the IFB/appendix. The purpose of the meeting will be to clarify issues and to answer questions on any matter that may be raised at that stage.
- 9.5 The Bidder is requested to submit any questions in writing, to reach the Employer not later than one week before the meeting.
- 9.6 Minutes of the pre-bid meeting, including the text of the questions raised, without identifying the source, and the responses given, together with any responses prepared after the meeting, will be transmitted promptly to all Bidders who have acquired the Bidding Document in accordance with ITB 8.2. Any modification to the Bidding Document that may become necessary as a result of the pre-bid meeting shall be made by the Employer exclusively through the issue of an addendum pursuant to ITB 10 and not through the minutes of the pre-bid meeting.
- 9.7 Nonattendance at the pre-bid meeting will not be a cause for disqualification of a Bidder.

## **10 Amendment of Bidding Documents**

10.1 Before the deadline for submission of bids, the Employer may modify the bidding documents by issuing online corrigendum. The corrigendum will appear on the web page of the website [www.uktenders.gov.in](http://www.uktenders.gov.in) under "Latest Corrigendum" and e-mail notification is also automatically sent to those bidders who have moved this tender to their "My Tenders" area.

10.2 Any addendum thus issued shall be part of the bidding documents and deemed to have been communicated to all the bidders who have moved this tender to their "My Tenders" area. In case of any addendum/corrigendum, the system will automatically send e-mails to all bidders who have downloaded the bidding document.

10.3 To give prospective bidders reasonable time in which to take an addendum into account in preparing their bids, the Employer may, at his description, extend as necessary the deadline for submission of bids, in accordance with Sub-Clause 21.2 below.

## **C. PREPARATION OF BIDS**

### **11. Language of the Bid**

11.1 All documents relating to the bid shall be in the English Language.

### **12. Documents Comprising the Bid**

#### **12.1. The bid shall comprise of:**

- a) Technical bid documents as per clause 4 of Section -1 of ITB.
- b) Financial bid i.e Priced Bill of Quantities for items specified (filled by the bidder including GST).

### **13. Bid Prices**

- 13.1 The contract shall be for the whole work as described in Sub-Clause 1.1, based on the priced Bill of Quantities submitted by the Bidder.
- 13.2 The bidder shall make online entries to fill in his offer rate item wise in the bill of quantities. GST shall be paid extra.
- 13.3 The rates and prices quoted by the bidder shall be fixed for the duration of the Contract and shall not be subject to adjustment on any account (For contracts up to 18 months period)

### **14. Currencies of Bid and Payment**

14.1. The unit rates and the prices shall be quoted by the bidder entirely in Indian National Rupees. All payments shall be made in Indian National Rupees (INR).

### **15. Bid Validity**

- 15.1. Bids shall remain valid for a period not less than 90 days after the deadline date for bid submission specified in Clause-21. A bid valid for a shorter period shall be rejected by the Employer as non-responsive. In case of discrepancy in bid validity period between that given by the undertaking pursuant to Clause 13.2(d) iv and the Form of Bid submitted by the bidder, the later shall be deemed to stand corrected in accordance with the former and the bidder has to provide for any additional security that is required.
- 15.2. In exceptional circumstances, prior to expiry of the original time limit, the Employer request that the bidders may extend the period of validity for a specified additional period. The request and the bidders' responses shall be made in writing or by cable. A bidder may refuse the request without forfeiting his bid security. A bidder agreeing to the request will not be required or permitted to modify his bid except, but will be required to extend the validity of his bid security for a period of the extension and in compliance with Clause 17 in all respects.

### **16. Bid Security**

16.1. The Bidder shall furnish as part of his Bid, a Bid security/EMD amount as shown in IFB (Volume-I) for this particular work. This bid security shall be in favour of Employer as named in Appendix and may be in one of the following forms:

- (a) Demand Draft payment from any scheduled Indian Bank and Nationalized Bank located in India and approved by the Reserve Bank of India.



(b) Bid Securing Declaration Form

- 16.2. Any bid not accompanied by an acceptable Bid Security and not secured as indicated in Sub-Clause 17.1 above.
- 16.3. The Bid Security of unsuccessful bidders will be returned within 90 days of the end of the Bid validity period specified in Sub-Clause 16.1.
- 16.4. The Bid Security of the successful bidder will be discharged when the bidder has signed the Agreement and furnished the required Performance Security.
- 16.5. The Bid Security may be forfeited.
- (a) If the bidder withdraws the bid after bid opening during the period of bid validity.
  - (b) If the Bidder does not accept the correction of the Bid Price pursuant to Clause 28; or
  - (c) In the case of a successful Bidder, if the Bidder fails within the specified time limit to.
    - (i) Sign the Agreement; or
    - (ii) Furnish the required Performance Security.

**17. Alternative Proposal by Bidders**

- 17.1 Bidders shall submit offers that fully comply with the requirements of the bidding documents, including the condition of contract (including mobilization advance or time for completion), basic technical design as indicated in the drawing and specifications. Conditional offer or alternative offers will not be considered further in the process of tender evaluation.

## **D. ONLINE SUBMISSION OF BID**

### **18. Bidding through E-Tendering System:**

**18.1.1** The bidding under this contract is electronic bid submission through website **www.uktenders.gov.in**. Detailed guidelines for viewing bids and submission of online bids are given on the website. The Invitation for Bids under Nagar Nigam Dehradun is published on this website. Any citizen or prospective bidder can logon to this website and view the Invitation for Bids and can view the details of works for which bids are invited. The perspective bidder can submit bids on line; however, the bidder is required to have enrolment/registration in the website and should have valid Digital Signature Certificate (DSC) in the form of smart card/e-token. The DSC can be obtained from any authorized certifying agencies. The Digital Signature registration has to be done with the e-token, after logging into the site. After this, the bidder can login the site through the secured login by entering the password of the e-token & the user id/ password chosen during registration.

After getting the bid schedules, the Bidder should go through them carefully and then submit the documents as asked, otherwise, the bid will be rejected.

**18.1.2** The completed bid comprising of documents indicated in ITB clause 13, should be uploaded on the website given above through e-tendering along with scanned copies of requisite certificates as are mentioned in different sections in the bidding document and scanned copy of bid security in case it is provided in the form of DD/online payment.

**18.1.3** The bidder shall furnish information as described in the Form of Bid on commissions or gratuities, if any, paid or to be paid to agents relating to the Bid, and to contract execution if the bidder is awarded the contract.

### **18.2 Electronic Submission of Bids: www.uktenders.gov.in**

**18.2.1** This is a **Two cover bid** so the bidder shall submit online in two files as Technical and Financial Part. The above files will have markings as given in the Appendix.

The contents of the Technical and Financial Qualification shall be as specified in clause 13 of the ITB. All the documents are required to be signed digitally by the bidder. After electronic on line bid submission, the system generates a unique bid identification number which is time stamped. This shall be treated as acknowledgement of bid submission.

### **19. Deadline for Submission of the Bids**

19.1. Complete Bids in two parts as per clause 18 above must be received by the Employer online not later than the date and time indicated in the Appendix.

19.2. The Employer may extend the deadline for submission of bids by issuing an amendment in accordance with Clause-11.3 in which case all rights and obligations of the Employer the bidders previously subject to the original deadline will then be subject to the new deadline.

**20. Late Bids**

- 20.1. The electronic bidding system would not allow any late submission of bids after due date & time as per server time.

**21. Modification and Withdrawal of Bids**

- 21.1. Bidders may modify their bids by uploading their request for modification before the deadline for submission of bids. For this the bidder need not make any additional payment towards the cost of tender document. For bid modification and consequential re-submission, the bidder is not required to withdraw his bid submitted earlier. The last modified bid submitted by the bidder within the bid submission time shall be considered as the bid. For this purpose, modification/ withdrawal by other means will not be accepted. In on line system of bid submission, the modification and consequential re-submission of bids is allowed any number of times. The bidders may withdraw his bid by uploading their request before the deadline for submission of bids, however, if the bid is withdrawn, the re-submission of the bid is allowed.
- 21.2. No bid shall be modified or withdrawn after the deadline of submission of bids.
- 21.3. Withdrawal or modification of a Bid between the deadline for submission of bids and the expiration of the original period of bid validity specified in Clause 15.1 above or as extended pursuant to clause 15.2 may result in the forfeiture of the Bid security pursuant to Clause 16.5.

## **E. BID OPENING AND EVALUATION**

### **22 Bid opening**

- 22.1** The Employer inviting bids or its authorized representatives will open the bids online and this could be viewed by the bidders also online.
- 22.2** The file containing the technical qualification part of the Two cover bid will be opened first.
- 22.3** In all cases, the amount of bid security, cost of bid documents, and validity of the bid shall be scrutinized. Thereafter, the bidders' name and such other details as the Employer may consider appropriate, will be notified as Part I bid opening summary by the authority inviting bids at the on-line opening. A separate electronic summary of the opening is generated and kept online.
- 22.4** The Employer will also prepare minutes of the Bid opening, including the information disclosed in accordance with Clause 21.3 of ITB and upload the same for viewing online.
- 22.5** Evaluation of Part I of bids with respect to bid security, qualification information and other information furnished in Part I of the bid in pursuant to Clause 12.1 of ITB, shall be taken up and a list will be drawn up of the qualified bidders whose are eligible for opening of Part II of bids.
- 22.6** The result of evaluation of Part I of the Bids shall be made public on e-procurement portal.
- 22.7.** The Employer shall inform, the bidders, who have qualified during evaluation of Part I of bids, of the date, time of online opening of Part II of the bid, if the specified date of opening of financial bid is changed.
- 22.8** Part II of bids of only those bidders will be opened online, who have qualified in Part I of the bid. The bidders' names, the Bid prices, the total amount of each bid, and such other details as the Employer may consider appropriate will be notified online by the Employer at the time of bid opening. Any Bid price, which is not declared and recorded, will not be taken into account in Bid Evaluation
- 22.9** The Employer shall prepare the minutes of the online opening of Part II of Bids and upload the same for viewing online.

### **23. Process to be Confidential**

Information relating to the examination, clarification, evaluation, and comparison of Bids and recommendations for the award of a contract shall not be disclosed to Bidders or any other persons not officially concerned with such process until the award to the successful Bidder has been announced. Any effort by a Bidder to influence the Employer's processing of Bids or award decisions may result in the rejection of his Bid.

### **24. Clarification of Bids and Contacting the Employer**

- 24.1** No Bidder shall contact the Employer on any matter relating to its bid from the time of the bid opening to the time the contract is awarded. If the bidder wishes to bring additional information to the notice of the Employer, it should do so in writing.

## **25. Examination of Bids and Determination of Responsiveness**

- 25.1. During the detailed evaluation of “Technical Bids”, the Employer will determine whether each Bid (a) meets the eligibility criteria defined in Clause-3 and 4; (b) has been properly signed; (c) is accompanied by the required securities and, (d) is substantial responsive to the requirement of the Bidding documents. During the detailed evaluation the “Financial Bid”, the responsiveness of the Bids will be further determined with response to the remaining bid conditions i.e. priced bill of quantities, technical specifications and drawings.
- 25.2 A substantially responsive “Financial Bid” is one which conforms to all the terms, conditions, and specifications of the Bidding documents, without material deviation or reservation. A material deviation or reservation is one (a) which affects in any substantial way the scope, quality, or performance of the Works: (b) which limits in any substantial way, Inconsistent with the Bidding documents, the Employer’s rights of the Bidder’s obligations under the Contract: or (c) whose rectification would affect unfairly the competitive position of other Bidders presenting substantially responsive Bids.
- 25.3 If a “Financial Bid” is not substantially responses, it will be rejected by the Employer, and may not subsequently be made responsive by correction in withdrawal of the non-conforming deviation or reservation

## **26. Correction of Arithmetical Errors**

- 26.1 During the evaluation of Price Bids, the Employer shall correct arithmetical errors on the following basis:
- (a) only for unit price contracts, if there is a discrepancy between the unit price and the total price that is obtained by multiplying the unit price and quantity, the unit price shall prevail and the total price shall be corrected, unless in the opinion of the Employer there is an obvious misplacement of the decimal point in the unit price, in which case the total price as quoted shall govern and the unit price shall be corrected;
  - (b) if there is an error in a total corresponding to the addition or subtraction of subtotals, the subtotals shall prevail and the total shall be corrected;
  - (c) if there is a discrepancy between the bid price in the Summary of Bill of Quantities and the bid amount in item (c) of the Letter of Price Bid, the bid price in the Summary of Bill of Quantities will prevail and the bid amount in item (c) of the Letter of Price Bid will be corrected; and
  - (d) if there is a discrepancy between words and figures, the amount in words shall prevail, unless the amount expressed in words is related to an arithmetic error, in which case the amount in figures shall prevail subject to (a), (b) and (c) above.
- 26.2 If the Bidder that submitted the lowest evaluated bid does not accept the correction of errors, its Bid shall be disqualified and its bid security may be forfeited or its bid securing declaration executed.

## **27. Evaluation and Comparison of Financial Bids**

- 27.1 The Employer will evaluate and compare only the Bids determined to be substantially responsive in accordance with Sub-Clause-25.

- 27.2 In evaluating the Bid, the Employer will determine for each Bids evaluated Bid Price by adjusting the Bid Price as follows,
- 27.2.1 Making any correction for errors pursuant to Clause-26; or
  - 27.2.2 Making appropriate adjustment for any other acceptance evaluations deviations: and
  - 27.2.3 Making appropriate adjustments to reflect discounts or other price modifications offered in accordance with Sub-Clause-21.8
- 27.3 The Employer reserves the right to accept or reject any variation or deviation. Variations and deviations and other factors, which are in excess of the requirements of the Bidding documents or otherwise result in unsolicited benefits for the Employer shall not be taken into account in Bid evaluation.
- 27.4 The estimated effect of the price adjustment conditions under Clause 51 of the Condition of Contract, during the period of implementation of the Contract, will not be taken into account in Bid evaluation.
- 27.5 If the Bid of the successful Bidder is seriously unbalanced in relation to the departmental estimated cost of work to be performed under the contract, the Employer may require the Bidder to produce detailed price analysis for any or all items of the Bill of Quantities, to demonstrate the internal consistency of those prices with the construction methods and schedule proposed. After evaluation of the price analysis, the Employer may require that the amount of the performance security set forth in Clause 30 of ITB be increased as below:
- (a) No Additional Performance Security for item rates up to 5% below the estimated item rate.
  - (b) An Additional Performance Security of 10% of the estimated cost of items, for item rates from 5% to 15 % below the estimated rate.
  - (c) An Additional Performance Security of 15% of the estimated cost of items, for item rates more than 15% below the estimated rate
- 27.6 A bid which contains several items in the Bill of Quantities which are unrealistically priced low and which cannot be substantiated satisfactorily by the bidder, may be rejected as non-responsive.

## **F. AWARD OF CONTRACT**

### **28. Award Criteria**

- 28.1. The Employer will award the contract to the Bidder whose Bid has been determined to be responsive to the Bidding documents and who has offered the lowest evaluated Bid Price, provided that such Bidder has been determined to be (a) eligible in accordance with the provisions of Clauses-3 and (b) qualified in accordance with the provisions of Clause-4. & to be within the available bid capacity adjusted to account for his bid price which is evaluated the lowest.

### **29 Employer's Right to accept any Bid and to reject any or all Bids.**

- 29.1 The Employer reserves the right to accept or reject any bid, and to annul the bidding process and reject all bids at any time prior to contract award, without thereby incurring any liability to Bidders, In case of annulment, all bids submitted and specifically, bid securities, shall be promptly returned to the Bidders

### **30. Notification of Award and Signing of Agreement.**

- 30.1 The Bidder whose Bid has been accepted will be notified of the award by the Employer prior to expiration of the Bid validity period by cable, telex or facsimile confirmed by registered letter. This letter (hereinafter and in the conditions of contract called the "Letter of Acceptance") will state the same that the Employer will pay the Contractor in consideration of the execution, completion, and maintenance of the Works by the Contractor as prescribed by the Contract (hereinafter and in the Contract called the "Contract Price"). The website has provision to display the details of award of work. The Employer shall publish on the website the result identifying the bid and the following information: (a) name of each bidder who submitted a bid; (b) bid prices as announced online during the bid opening of Part II of the bids; (c) name and evaluated prices of each bid; (d) name of bidders whose bids were rejected during evaluation of either Part I or Part II of the bids and the reasons for their rejection; and (e) name of the winning bidder the price offered and summary scope of the contract awarded
- 30.2 The notification of award will constitute the formation of the Contract, subject only to the furnishing of a performance security in accordance with the provisions of Clause-30.
- 30.3 The Agreement will incorporate all documents between the Employer and the successful Bidder. It will be signed by the Employer and the successful Bidder in the office of the Employer, within 07 days after receipt of the Performance Guarantee by the Employer.
- 30.4 Upon the furnishing by the successful Bidder of the Performance Security the Employer will promptly notify the other Bidders that their Bids have been unsuccessful.

### **31. Performance Security (Performance Guarantee)**

- 31.1 Within 14 days of receipt of the Letter of Acceptance, the successful Bidder shall deliver to the Employer a Performance Security (Performance Guarantee) in any of the forms given below for an amount equivalent to 5% of the Contract price or estimated cost whichever is more and additional security for unbalanced Bids in accordance with Clause-28.5 of ITB and Clause-55 of Conditions of Contract. If the contractor fails to submit the above within 14 days, he shall pay interest to MUNICIPAL COMMISSIONER, NAGAR NIGAM DEHRADUN @ 12% in the form of FDR/Bank Guarantee for beyond 14 days and upto 30 days with the request letter for extension of time for submission of performance guarantee.

- (a) FDR/Bank Guarantee as indicated in Appendix. (Refer Section-7).

The Performance Security and Additional Performance Security as applicable shall be refunded to the contractor after satisfactory completion of the works and after the payment of the final bill.

- 31.2 Failure of the successful Bidder to comply with the requirements of Sub-clause 35.1 shall constitute sufficient grounds for cancellation of the award and forfeiture of the Bid Security.
- 31.3 The employer shall retain from each payment due to the Contractor an amount of 5% of Bill amount subject to a maximum of 5% of the contract price until the defect liability period has passed and the Engineer has certified that all the defects notified by the Engineer to the Contractor before the end of this period have been corrected. The Defect Liability Period shall be 12 months from the date of issuance of completion certificate by Engineer-in-charge.

### **32. Advance Payment and Security**

- 32.1 The Employer may provide an Advance Payment on the Contract Price as stipulated in the Conditions of Contract, subject to maximum amount, as stated in the Contract Data.

### **33. Dispute Review Expert**

- 33.1 Dispute Review Expert/ Conciliator is indicated in Appendix

### **34. Corrupt or Fraudulent Practices**

- 34.1 The employer requires the Bidders/Suppliers Contractors under this contracts observe the highest standard of ethics during the procurement and execution of this contract. In pursuance of this policy:
- a) "Corrupt practice" means the offering, giving, receiving for soliciting of anything of value to influence the action of a public official in the procurement process or in contract execution and
  - b) "Fraudulent practice" means a misrepresentation of facts in order to influence a procurement process or the execution of a contract to the detriment of the Employer and includes collusive practice among Bidders (Prior to or after bid submission) designed to establish bid prices at artificial non-competitive levels and to deprive the Employer of the benefits of free and open competition.
  - c) The Employer will reject a proposal for award of work if he determines that the Bidder recommended for award has engaged in corrupt or fraudulent practices in completing for the contract in question.
  - d) The Employer will declare a Bidder ineligible either indefinitely or for a stated period of time, for award of a contract/contracts if he, at any time determines that the Bidder has engaged in corrupt or fraudulent practices in competing for, or in executing the contract.



## Contract Data

Clause Reference  
With respect to  
Section-1

1.	Name of the Employer is <b>Municipal Commissioner, Nagar Nigam Dehradun.</b>	[CL.1.1]												
2.	The last five years 2018-2019 2019-2020 2020-2021 2021-2022 2022-2023	[CL.4.3 (A)]												
3.	Minimum annual value of general construction work over last five years: <b>Rs 91.73 Lacs</b>	[Cl.4.3A(i)]												
4.	Satisfactorily completed atleast one similar work (till publishing date of this RFP): <b>Rs. 73.38 Lac</b> or, Atleast two similar works worth: <b>Rs. 45.87 Lac</b> in the last five years which shall be indexed as below: -  <table style="margin-left: auto; margin-right: auto;"> <thead> <tr> <th style="text-align: center;">Year</th> <th style="text-align: center;">Escalation Factor</th> </tr> </thead> <tbody> <tr> <td style="text-align: center;">2018-2019</td> <td style="text-align: center;">1.61</td> </tr> <tr> <td style="text-align: center;">2019-2020</td> <td style="text-align: center;">1.46</td> </tr> <tr> <td style="text-align: center;">2020-2021</td> <td style="text-align: center;">1.33</td> </tr> <tr> <td style="text-align: center;">2021-2022</td> <td style="text-align: center;">1.21</td> </tr> <tr> <td style="text-align: center;">2022-2023</td> <td style="text-align: center;">1.1</td> </tr> </tbody> </table>	Year	Escalation Factor	2018-2019	1.61	2019-2020	1.46	2020-2021	1.33	2021-2022	1.21	2022-2023	1.1	[Cl.4.3A(ii)]
Year	Escalation Factor													
2018-2019	1.61													
2019-2020	1.46													
2020-2021	1.33													
2021-2022	1.21													
2022-2023	1.1													
5.	Similar Works Exp-. <b>Civil works</b>	[Cl.4.3A(iii)]												
6.	Average annual financial turn during the last three financial years: <b>Rs 27.52 Lacs</b>	[Cl.4.3(C)]												
7.	Liquid assets and/or availability of credit facilities: <b>Rs. 30.27 Lac</b>	[Cl.4.3(C)]												
8.	Pre-bid meeting to be held at Venue- <b>Office of Municipal Commissioner, Nagar Nigam Dehradun</b> <b>Date: 27/05/2023</b> <b>Time: 11:00 AM</b>	[Cl.9.4]												
09.	The technical bid will be opened online at Venue: <b>Office of Municipal Commissioner, Nagar Nigam Dehradun</b>	[Cl.22.1]												
10.	Address of employer: <b>Office of Municipal Commissioner, Nagar Nigam Dehradun</b>	[Cl.9.1]												
11.	The bids should be submitted latest by 4:00 PM on 12/06/2023	[Cl.19.1]												
12.	The bid security shall be in favour of <b>Finance Controller, Nagar Nigam Dehradun</b> issued from any nationalized/scheduled bank, payable at Dehradun	[Cl.8.2, Cl.16.1]												
115.	The name of Dispute Review Expert is- <b>Mr. J. P. Raturi, (E.E.,Nagar Nigam Dehradun.</b>	[Cl.33.1]												

**Annexure -I****List of Machinery/Equipments required for the on-Contract Work  
[Refer Clause 4.4 B(a) of ITB]**

<b>Sl. No.</b>	<b>Item of Equipment</b>	<b>* No. Owned/ Leased</b>
1.	Water Tanker	4 Nos.
2.	C.C. Batching Mix Plant (1 M <sup>3</sup> )	1 No.
3.	Concrete Mixer with lift	2 No.
4.	Concrete Mixer with hopper with pipe line /Transit mixer/Boom Pump	2 No.
5.	JCB Machine	1 No.
6.	Pin/ Needle Vibrator/ Surface Vibrator	6 Nos
7.	Generator 25 KVA	1 No.
8.	Grinding/Polishing Machine	2 No.
9.	Concrete Pump.	2 No.
10.	Stone cutting machine	6 Nos.
11.	Shuttering	3000 m <sup>2</sup>
12.	Leveling machine	1 No.
13.	Theodolite	1 No.
14.	Total Station machine	1 No.
15.	Site lab testing equipment	
	i -Cube testing machine	1 No.
	ii- Cube mould	30 Nos.
	iii- Slump cone	2 Nos.
	iv- Varnire Calipers	1 No.
	v- Screw gauge	1 No.
	vi- Weighing machine	1 No.
	vii- Silt testing container	4 Nos.
	viii- Sieves as per IS for coarse & fine aggregate	Complete Set
16	Welding Machine	2 Nos.
17	Drill Machine	3 Nos.
18	Cutter Machine	3 Nos.
19	Multimeter	2 Nos.
20	Crimping tool	2 Nos.
21	Punching tool	2 Nos

22	Weight Machine Coarse	2 Nos
23	Line tester	2 Nos.
24	Pliers	5 Nos.
25	Screw Drivers	5 set.
26	Megar	1 No.
27	Earth Tester	1 No.
28	Multi meter/ Tong Tester	1 No.
29	Crimping Tools	1 No.

**\* List is indicative; Nos. shall change as per nature of the work.**

**List of Key Personnel to be Employed on Contract Work**  
**[Refer Clause 4.4 B(b) of ITB]**

Sl. Nos	Cost of Work	Nos. of Key Personnel (Minimum Qualification & Experience)		
		Degree Engineering (Civil)	Diploma Engineering (Civil & Electrical each)	Supervisor (10+2)
i.	Upto Rs. 1 Crore	-	1 (2 yrs.)	1 (2 yrs)
ii.	Above Rs. 1 Crore and upto Rs. 5 Crore	-	2 (3 yrs.)	2 (3yrs.)
iii.	Above Rs. 5 Crore and upto Rs. 10 Crore	1 (2 yrs.)	2 (3yrs.)	2 (3 yrs.)
iv.	Above Rs. 10 Crore and upto Rs. 25 Crore	1 (4 yrs.)	2 (5 yrs.)	2 (5 yrs.)
v.	Above Rs. 25 Crore	2 (6 yrs. & 4 yrs.)	3 (5 yrs.)	4 (5 yrs.)

## **SECTION-2**

### **QUALIFICATION INFORMATION (QI)**

## QUALIFICATION INFORMATION

### (Refer Clause 4 of ITB)

The information to be filled by the bidder at the following pages will be used for purposes of post qualification as provided for in **Clause-4** of the Instructions to Bidders. This information will not be incorporated in the Contract.

#### 1.1 **General Information (Refer Clause 4.2 (g) of ITB.**

(a)	Name of Firm:	
(b)	Head Office Address:	
(c)	Local office Address:	
(d)	Telephone:	Contact Person: Nationality:
(e)	Fax Nos.	e-mail:
(f)	Place of Incorporation/Registration and In corporation/Registration Nos.	
(g)	Place and Business:-	
(h)	Name and Designation of power Attorney (Attach certified copy)	
(i)	Main Lines of Business :	
(j)	PAN Nos. and GST Nos. :	

#### 1.2. Total value of Civil Engineering work performed in the last Five years on Rs. 91.73 Lacs Refer Clause 4.3 (A.i) of ITB]

<b>Year</b>	<b>Cost of Project**</b>
2018-2019	.....
2019-2020	.....
2020-2021	.....
2021-2022	.....
2022-2023	.....
<b>Total</b>	.....

\* **Immediately preceding the financial year in which bid is received.**

\*\* **Attach certificate from Chartered Accountant.**

1.3 The details of similar works performed as prime contractor over the last five years.\*\* [Refer Clause 4.3 (A.ii) of ITB]

<b>Years**</b>	<b>Project Name</b>	<b>Name of the Employer*</b>	<b>Description of work</b>	<b>Contract Nos.</b>	<b>Value of Contract (Rs. Crore)</b>	<b>Date of issue of work order</b>	<b>Stipulated period of completion</b>	<b>Actual date of completion*</b>	<b>Remarks explaining reasons for delay &amp; work completed</b>
<i>1</i>	<i>2</i>	<i>3</i>	<i>4</i>	<i>5</i>	<i>6</i>	<i>7</i>	<i>8</i>	<i>9</i>	<i>10</i>

\* Attach certificate(s) from the Engineer(s)-in-charge.

\*\* Immediately preceding the financial year in which bid is received.

1.4 Information of Bid Capacity (works for which bids have been submitted and works which are yet to be completed) as on the date of this bid.

(A) Existing commitments and on-going works: [Refer Clauses 4.5 of ITB]

Description of works	Place & Date	Contract Nos.	Name & Address of Employer	Value of Contract (Rs. Cr.)	Stipulated Period of Completion	Value of works * remaining to be completed (Rs. Cr.)	Anticipated date of completion
<i>1</i>	<i>2</i>	<i>3</i>	<i>4</i>	<i>5</i>	<i>6</i>	<i>7</i>	<i>8</i>

\* Attach certificate(s) from the Engineer-in-charge.



1.4 (B) Works for which bids already submitted: [Refer Clauses 4.5 of ITB]

Description of works	Place & State	Name & Address of Employer	Estimated value of works (Rs. Cr.)	Stipulated period of completion	Date when decision is expected	Remarks if any
<i>1</i>	<i>2</i>	<i>3</i>	<i>4</i>	<i>5</i>	<i>6</i>	<i>7</i>

1.5 Availability of key items of Contractor's Equipment essential for carrying out the works [Refer Clause-4.3 B (a)]. The Bidder should list all the information requested below;

Item of Equipment	Requirement		Availability proposals			Remarks (from whom to be purchased)
	Nos.	Capacity	Owned/Leased to be procured	Nos./ Capacity	Age/ Condition	
<i>1</i>	<i>2</i>	<i>3</i>	<i>4</i>	<i>5</i>	<i>6</i>	<i>7</i>

1.6 Qualification and experience of key personnel required for administration and execution of the Contract [Refer Clause-4.3 B (b)]. Attach biographical data;

<b>Position</b>	<b>Name</b>	<b>Qualification</b>	<b>Year of Experience (General)</b>	<b>Years of experience in the proposed position</b>
<i>1</i>	<i>2</i>	<i>3</i>	<i>4</i>	<i>5</i>

1.7 Proposed sub-contracts and firms involved. [Refer Clause 4.4 of ITB]

<b>Items of the works</b>	<b>Value of Sub contract</b>	<b>Sub contractor (Name &amp; Address)</b>	<b>Experience in similar work</b>
<i>1</i>	<i>2</i>	<i>3</i>	<i>4</i>

**Attach copies of certificates on possession of valid license as required and experience for Services (Electrical, Fire Fighting, HVAC works )**

- 1.8 Financial reports for the last five years: balance sheets, profit and loss statements, auditors' reports (in case of companies/corporation), etc. List them and attach copies.
- 1.9 Evidence of access to financial resources to meet the qualifications requirements: cash in hand, lines of credit, etc. List them and attach copies of support documents.
- 1.10 Name, address, and telephone, telex, and fax numbers of the Bidders' bankers who may provide references if contacted by the Employer.
- 1.11 Information on litigation history in which the Bidder is involved [Refer Clause 4.2(s)].

Other Party (ies)	Employer	Cause of Dispute	Amount involved	Remarks showing Present Status

- 1.12 Statement of compliance under the requirements of Sub clause-3.2 of the instructions to Bidders, (Name of consultant engaged for project preparation is (.....)).
- 1.13 Proposed work method and schedule. The Bidder should attach descriptions, drawings and charts as necessary to comply with the requirements of the Biddings documents. [Refer ITB Clause 4.2 (u)].
- 1.14 Programme
- 1.15 Quality Assurance Programme

**2 Additional Requirements**

- 2.1 Bidders should provide any additional information required to fulfill the requirements of Clause 4 of the Instructions to the Bidders of applicable.
  - (a) Affidavit for submitting correct information etc.
  - (b) Undertaking for not having any association with the consultant or any other entity connected of the subject work.

---

**Note:- Clause 1.8 to 1.11 of Qualification Information (QI) are not applicable for prequalified Contractors/Firms.**

## **BANK CERTIFICATE**

### **Availability of Credit Facilities**

**(Refer Clause 4.2 (j) of ITB)**

This is to certify that M/s \_\_\_\_\_ is a construction company with a good financial standing.

If the contract for the work, namely “\_\_\_\_\_” is awarded to the above firm, we shall be able to provide overdraft/credit facilities to the extent of Rs. \_\_\_\_\_ to meet their working capital requirements for executing the above contract during the contract period.

**(Signature)**

**Name of Bank**

**Senior Bank Manager**

**Address of the Bank**

## **Affidavit on Rs. 100 Stamp Paper**

1. I the undersigned do hereby undertake that our firm M/S \_\_\_\_\_ agree to abide by this bid for a period of 90 days for the date fixed for receiving on line the same and it shall be binding on us and may be accepted at any time before the expiration of that period.
2. I, the undersigned do hereby certify that all the statements made in the required attachments are true and correct.
3. The undersigned also hereby certifies that neither our firm M/s \_\_\_\_\_ has abandoned any work in India nor any contract awarded to us for such works have been rescinded and that our firm has not been blacklisted in India during last five years prior to the date of this bid.
4. The undersigned hereby authorize(s) and request(s) any bank, person, firm or corporation to furnish pertinent information deemed necessary and requested by the Department to verify this statement or regarding my (our) competence and general reputation.
5. The undersigned understands and agrees that further qualifying information may be requested, and agrees to furnish any such information at the request of the Department/Project implementing agency.
6. The specialized works e.g. electrical, fire fighting, HVAC system, IT & communication system shall be carried out by the expert personnel or license holder (as may be applicable) as per direction of the Employer.
7. I, the undersigned understand and agree for adhering to Special Conditions of Contracts for implementation of measures for protection of environment.
8. The undersigned do hereby undertake that our firm M/s \_\_\_\_\_ would invest minimum cash up to 20% of the contract value of the work during implementation of the Contract.
9. The undersigned do hereby undertake that our firm M/s \_\_\_\_\_ is not associated directly or indirectly, with the Consultant or any other entity that has prepared the design, specifications, and other documents for the Project.
10. The decision of evaluation committee in any case shall be acceptable to us.

\_\_\_\_\_  
(Signed by an Authorized Officer of the Firm)

\_\_\_\_\_  
Title of Officer

\_\_\_\_\_  
Name of Firm

\_\_\_\_\_  
DATE

**Annual Turnover Data**  
**[Refer clause 4.3 (C) of ITB]**

Name of Applicant:

All firms must complete the information in this form. The information regarding to the all turn over of Applicant in terms of the amount billed to the clients for each i.e. work in progress or completed.

<b>Average Annual Financial Turnover Data (For construction works only) for the last three year</b>	
<b>Turnover (Rupees in Lacs)</b>	
2020-2021	
2021-2022	
2022-2023	

Data to be certified by registered Chartered Accountant Firm.



**FORM OF BID**

[Refer Clause 4.2(m), section-1, ITB]

**Description of work:**

To : Municipal Commissioner,  
Nagar Nigam Dehradun

- 1- We offer to execute the work described above and remedy any defects there in conformity with the conditions of contract specification, drawing, bill of quantity and addenda based on item rate quoted by me on the Schedule- B (Bill of Quantity).
- 2- We undertake, if our Bid is accepted, to commence the Works as soon as is reasonable possible after the receipt of the Engineer's notice to commence, and to complete the whole of the Works comprised in the Contract within the time stated in the document.
- 3- We agree to abide by this Bid for the period of 90 days from the date fixed for receiving the same, and it shall remain binding upon us and may be accepted at any time before the expiry of that period.
- 4- Unless and until a formal agreement is prepared and executed this bid, together with your written acceptance thereof, shall constitute a binding contract between us.
- 5- We understand that you are not bound to accept the lowest or any tender you may receive.
- 6- We accept the appointment of **Mr. J. P. Raturi**, Executive Engineer, Nagar Nigam Dehradun as Dispute Review Expert if required.

Dated this .....day of .....20.....

Signature ..... in the capacity of .....duly  
authorized to sign bids for and on behalf of.....  
..... (in block capital or typed)

**SECTION – 3**

**CONDITIONS OF CONTRACT**

# CONDITIONS OF CONTRACT

## TABLE OF CONTENTS

<b>A.</b>	<b>General</b>	<b>Pg.No</b>	<b>D.</b>	<b>Cost Control</b>	<b>Pg.No</b>
1.	Definition	44	43.	Bill of Quantities	56
2.	Interpretation	45	44.	Variations	56
3.	Language and Law	46	45.	Payments for variations	58
4.	Engineer's Decisions	46	46.	Cash flow forecasts	58
5.	Delegation	46	47.	Payment certificate	58
6.	Communications	46	48.	Payment's measurement of work done	58
7.	Sub-contracting	46	49.	Tax	60
8.	Other Contractors	46	50.	Currencies	60
9.	Personnel	47	51.	Price Adjustment	60
10.	Employer's Contractor's Risk	47	52.	Retention (Security Deposit)	60
11.	Employer's Risks	47	53.	Liquidated Damages/compensation for delay	60
12.	Contractor's Risks	47	54.	Advance Payment	61
13.	Insurance	47	55.	Securities	61
14.	Site Investigation Reports	48	56.	Payment Terms	61
15.	Queries about the Contract Data	48	57.	Cost of Repair	61
16.	Contractor to Construct the works	48	58.	Royalty payable on minor minerals- Employer to be indemnified.	61
17.	The works to be completed by the intended completion date	48	59.	Production of Vouchers etc by the contractor	61
18.	Approval by the Engineer	48	<b>E. Finishing the Contract</b>		
19.	Safety	48	60.	Completion	63
20.	Discoveries	48	61.	Taking over	63
21.	Possession of the site	48	62.	Final Account (Final Bill)	63
22.	Access to the Site	49	63.	Operating and Maintenance Manuals	63
23.	Instructions	49	64.	Termination	63
24.	Dispute	49	65.	Payment upon Termination	64
25.	Procedure for Disputes	49	66.	Property	65
26.	Replacement & Dispute Review Expert	50	67.	Foreclosure of contract due to abandonment or reduction in scope of work.	65
27.	Unauthorized occupation of building during Construction	50	68.	Termination of Contract on death of Contractor	66
28.	Changes in firm's Constitution to be intimated.	51	69.	Work to be Carried out on Risk & Cost	66
29.	Electricity supply required at the works.	51	70.	Release from performance	67
30.	Unfiltered water supply required for the work.	51	<b>F. Special Condition of Contract</b>		
31.	Watching and Lightings.	51	71.	Labour	68
<b>B. Time Control</b>			72.	Compliance with labour regulations.	68
32.	Programme	52	73.	Salient Features of some major Labour Laws	68
33.	Extension of the intended completion date	52	74.	Arbitration	72
34.	Delays Ordered by the Engineer	52	75.	Protection of Environment	73
35.	Early Warning	53			
<b>C. Quality Control</b>					
36.	Identifying defects	54			
37.	Work to be open to inspection	54			
38.	Notice to be given before work is covered up	54			
39.	Tests	54			
40.	Correction of Defects	54			
41.	Uncorrected Defects	54			
42.	Action where no Specifications are specified	55			

# GENERAL CONDITIONS OF CONTRACT

## A. GENERAL

### 1. Definitions

1.1. Terms which are defined in the Contract Data are not also defined in the Conditions of Contract but keep their defined meanings, Capital initials are used to identify defined terms.

The **Adjudicator** (synonymous with **Disputed Review Expert** is the person appointed jointly by the Employer and the Contractor to resolve disputes in the fined instance as provided of in Clause 24 and 25, **The name of the Adjudicator defined in the Contract Data.**

**Bill of Quantities** means the priced and completed Bill of Quantities forming part of the Bid.

**The Client means the user department**

The **Completion Date** is the date of completion of the works as certified by the Engineer in accordance with sub-Clause 63.1.

The **Contract** is the contract between the Employer and the Contractor to execute complete and maintain the works. It consists of the documents listed in Clause 2.3 below.

The **Contract Data** defined the documents and other information which comprise the contractor.

The **Contractor** is a person or corporate body whose Bid to carry out the work has been accepted by the Employer.

The **Contractor's Bid** is the completed Bidding document submitted by the Contractor to the Employer and includes Technical and Financial Bids.

The **Contractor Price** is the price stated in the Letter of Acceptance and thereof as adjusted in accordance with the provisions of the Contract.

**Days** are calendar days months are calendar months.

A **Defect** is any part of the works not completed in accordance with the contract.

A **Defects Liability Period** is the period named in the Contract Data calculated from the Completion date.

**Drawings** include calculations and other information provided or approved by the Engineer for the execution of the Contract.

The **Employer** is the party who will employ Contractor to carry out the works.

The **Engineer/Engineer – in- charge** is the person named in the Contract Data (or any other competent person appointed and notified to the contractor to act in replacement of the Engineers) who is responsible for supervising the contractor, administering the contract certifying payments due, to the contractor, issuing and valuing, variations to the contract according extensions of time and valuing the compensation events.

**Equipment** is the Contractor's machinery and vehicles brought temporarily to the site to construct the work.

**Force Majeure** means an exceptional event or circumstance: which is beyond a Party's control; which such Party could not reasonably have provided against before entering into the Contract; which, having arisen, such Party could not reasonably have avoided or overcome; and, which is not substantially attributable to the other Party.

The **Initial Contract Price** is the Contract Price listed in the Employer's Letter of Acceptance.

The **Intended Completion Date** is the date on which it is intended that the Contractor shall complete the works. The Intended Completion Date is specified in the Contract Data. The Intended Completion Date may be revised only by the Engineer by issuing an extension of time.

**Letter of Acceptance** means the formal acceptance by the Employer of the Bid and denotes the formation of the Contract at the date of acceptance.

**Materials** are all supplies, including consumables, used by the contractor for incorporation in the works.

**Plant** is any integral part of the works which is to have a mechanical, electrical, electronic or chemical or biological function.

The **Site** is the area defined as such in the Contract Data.

**Site Investigation Reports** are those which were included on the Building documents and are factual interpretative reports about the surface and sub-surface conditions at the site.

**Specification** means the Specification of the works included in the Contract and any modification or addition made or approved by the Engineer.

The **Start Date** is given in the Contract Data. It is the date even the Contractor shall commence execution of the works. It does not necessarily coincide with any of the Site Possession Dates.

A **Subcontractor** is a person or corporate body who has a contract with the Contractor to carry out a part of the work in the Contract which includes work on the Site.

**Temporary Works** are works designed, constructed, installed and removed by the Contractor which are needed for construction or installation of the works. A **Variation** is an instruction given by the Engineer which varies the works.

The **Works** are what the Contract requires the Contractor to construct, install and turn over to the Employer as defined in the Contract Data.

## **2. Interpretation**

2.1. In interpreting these Conditions of Contract singular also means plural, male also means female or neuter, and the other way around, Heading has no significance. Words have their normal meaning under the language of the Contract unless specifically defined. The Engineer will provide instructions clarifying questions conditions, contract.

- 2.2. If sectional completion is specified in the Contract Data references in the Conditions of Contract to the Works, the Completion Date and the Intended Completion Date apply to any Section of the Works (other than references to the Completion Date and Intended Completion Date for the whole of the Works).
- 2.3. The documents forming the Contract shall be interpreted in the following order of priority.
- (a) Agreement
  - (b) Letter of Acceptance, notice to proceed with the works
  - (c) Contractor's Bid
  - (d) Contract Data
  - (e) Conditions of Contract including Special Conditions of Contract.
  - (f) Specifications
  - (g) Drawings
  - (h) Bill of Quantities and
  - (i) Any other document listed in the Contract Data as forming part of the Contract.

### **3. Language and law.**

- 3.1. The language of the Contract and the law governing the Contract are stated in the Contract Data.

### **4. Engineer's Decisions**

- 4.1. Except where otherwise specifically stated, the Engineer will decide contractual matters between the Employer and the Contractor in the role representing the Employer.

### **5. Delegation**

- 5.1. The Engineer may delegate any of his duties and responsibilities to other people except to the Adjudicator after notifying the Contractor and may cancel any delegation after notifying the Contractor.

### **6. Communications**

- 6.1. Communications between parties which are referred to in the conditions are effectively only when in writing. A notice shall be effective only when it is delivered (in terms of Indian Contract Act).

### **7. Sub Contractor**

- 7.1. The Contractor may sub-contract any portion of work, up to a limit specified in Contract Data, with the approval of the Engineer but may not assign the Contract without the approval of the **Employer** in writing. Sub-contracting does not alter the Contractor's obligations.

### **8. Other Contractors**

- 8.1. The Contractor shall cooperate and share the Site with other contractors, public authorities, utilities, and the Employer between the dates given in the Schedules of other Contractors. The Contractor shall as refer to in the Contract Data, also provide facilities and services for them as described in the Schedule. The employer may modify the schedule of other contractors and shall notify the contractor of any such modification.

## **9. Personnel**

- 9.1. The Contractor shall employ the key personnel named in the Schedule of Key Personnel as referred to in the Contract Data to carry out the functions stated in the Schedule or other personnel approved by the Engineer. The Engineer all approved any proposal replacement of key personnel only if their qualifications, abilities and relevant experience are substantially equal to or better than those of the personnel listed in the Schedule. [Refer Section-1, Annexure-II, Ref Clause 4.5 B (b)]
- 9.2. If the Engineer asks the Contractor to remove a person who is a member of the Contractor's staff or his work force stating the reasons the Contractor shall ensure that the person leaves the Site within seven days and has no further connection with the work in the Contract.

## **10. Employer's and Contractor's Risks**

- 10.1. The Employer carries the risk which this Contract state are Employer's Risk and the Contractor carries the risks which this Contract states are Contractor's risks.

## **11. Employer's Risks**

- 11.1. The Employer is responsible for the expected risks which are (a) is so far as they directly affect the execution of the Works in India the risks of war, hostilities, invention, act of foreign enemies, rebellion, revolution, installation of military or usurped pavers civil war, riot commotion or disorder (unless restricted to the Contractor to the Contractor's employee and contamination from any nuclear rule or nuclear waste or radioactive toxic explosive, or (b) a cause due solely to the design of the works other that the Contractor design.

## **12. Contractor's Risks**

- 12.1. All risks of loss or damage to physical property and of personal/ injury & death which arise during and in consequence of the performance of the Contract then the expected risks are the responsibility of the Contractor.

## **13. Insurance**

- 13.1. The Contractor shall provide, in the joint names of the Employer and the Contractor, insurance cover from the Start Date to the end of the Defect Labiality Period the amounts and deductibles stated in the Contract Data for the following events which are due to the Contractor's risks.
  - (a) Loss of or damages to the Works, Plant and Material.
  - (b) Loss of or damages to Equipments.
  - (c) Loss of or damages of property (except the works, plant, materials and equipment) in connection with the contract; and
  - (d) Personal injury or death.
- 13.2. Policies and certificates for insurance shall be delivered by the Contractor to the Engineer for the Engineer's approval before the Start Date. All each insurance shall provide for compensation to be payable in the types and proportions of currencies required to rectify the loss or damage incurred.
- 13.3. If the Contractor does not provide any of the policies and certificates required, the Employer may affect the insurance which the Contractor should have provided and recover the premiums the Employer has paid from payments otherwise due to the Contractor or, if no payment is due, the payment of the premiums shall be debt due.
- 13.4. Alterations to the terms of insurance shall not be made without the approval of the Engineer.

13.5. Both parties shall comply with any conditions of the insurance policies.

#### **14. Site Investigation Reports**

14.1. The Contractor, in preparing the Bid, shall rely on any site investigation reports referred to in the Contract Data, supplemented by any information available to the Bidder.

#### **15. Queries about the Contract Data**

15.1 The engineer will clarify queries on the Contract Data.

#### **16. Contractor to Construct the Works**

16.1. The Contractor shall construct and install the Works in accordance with the Specification and Drawings.

#### **17. The Works to be Completed by the Intended Completion Date**

17.1. The Contractor may commence execution of the Works on the Start Date and shall carry out the works in accordance with the programme submitted by the Contractor, as updated with the approval of the Engineer, and complete them by the intended Completion Date.

#### **18. Approval by the Engineer**

18.1. The Contractor shall submit Specifications and Drawings showing the propose Temporary Works to the Engineer, who is to approve them if they comply with the Specification and Drawings.

18.2. The Contractor shall be responsible for design of Temporary Works.

18.3. The Engineer's approval shall not alter the Contractor's responsibility for design of Temporary Works.

18.4. The contractor shall obtain approvals of third parties to the design of the temporary works, where required are subject to prior approval by the Engineer before their use.

#### **19. Safety**

19.1. The Contractor shall be responsible for the safety of all activities on the site by providing safety jackets, helmets etc for their workers as well as to the staff of Nagar Nigam Dehradun deployed at the site.

19.2. GI sheet barricading, temporary fencing, guards, lights and protection works is to be installed by the contractor in order to segregate the execution site. No extra payment will be paid to the Contractor for this work. The work is to be carried out as per instruction/ satisfaction of Engineer-in-charge.

#### **20. Discoveries**

20.1. Anything of historical or other interest or of significant value unexpectedly discovered of the site is the property of the Employer. The Contractor is to notify the Engineer of such discoveries and carry out the Engineer's instructions of dealing with them.

#### **21. Possession of the Site.**

21.1. The Employer shall give possession of all parts of the site to the Contractor, If possession of a part is not given by the date stated in the Contract Data the Employer is deemed to have delayed the start of the relevant activities and this will be Compensation Event.

21.2. Site office should be established by the contractor within 15 days of award of work.



## **22. Access of the Site**

- 22.1. The Contractor shall allow the Engineer and any person authorized by the Engineer access to the site, to any place where work in connection with the Contract is being carried out or is intended to be carried out and to any place where material or plant are being manufactured/fabricated/assembled for the works.

## **23. Instructions**

- 23.1. The Contractors shall carry out all instructions of the Engineer pertaining to works which comply with the applicable laws where the site is located.
- 23.2. The Contractor shall permit the Employer to inspect the Contractor's accounts and recovered relating to the performance of the Contractor and to have them audited by audit appointed by the Employers if so required by the Employer.

## **24. Disputes**

- 24.1. If the contractor believes that a decision taken by the Engineer was either outside the authority given to the Engineer by the Contract or that the decision was wrongly taken, the decision shall be referred to the Dispute Review Expert as stated in Contract data, within 14 days of the notification of the Engineer's decision.

## **25. Procedure for Disputes**

- 25.1. The Dispute Review Expert shall give a decision in writing within 28 days of receipt of a notification of dispute.
- (a) If the contractor is dissatisfied with the instructions or decision of the Dispute Review Expert, the contractor may, within 15 days of the receipt of the decision, appeal to the Municipal Commissioner, Nagar Nigam Dehradun who shall afford an opportunity to the contractor to be heard, if the latter so desires, and to offer evidence in support of his appeal. The Municipal Commissioner, Nagar Nigam Dehradun shall give his decision within 30 days of receipt of contractor's appeal. If the contractor is dissatisfied with this decision, the contractor shall within a period of 30 days from receipt of the decision, give notice to the Municipal Commissioner, Nagar Nigam Dehradun for appointment of arbitrator failing which the said decision shall be final, binding and conclusive and not referable to adjudication by the arbitrator.
- (b) Except where the decision has become final, binding and conclusive in terms of Sub Para (a) above, disputes or difference shall be referred for adjudication through arbitration by a sole arbitrator appointed by the Municipal Commissioner, Nagar Nigam Dehradun. If the arbitrator so appointed is unable or unwilling to act or resigns his appointment or vacates his office due to any reason whatsoever, another sole arbitrator shall be appointed in the manner aforesaid. Such person shall be entitled to proceed with the reference from the stage at which it was left by his predecessor.
- (c) It is a term of this contract that the party invoking arbitration shall give a list of disputes with amounts claimed in respect of each such dispute along with the notice for appointment of arbitrator and giving reference to the rejection by the Municipal Commissioner, Nagar Nigam Dehradun of the appeal.
- (d) It is also a term of this contract that no person, other than a person appointed by Municipal Commissioner, Nagar Nigam Dehradun as aforesaid should act as arbitrator.

- (e) It is also a term of this contract that if the contractor does not make any demand for appointment of arbitrator in respect of any claims in writing as aforesaid within 120 days of receiving the intimation from the Engineer-in-charge that the final bill is ready for payment, the claim of the contractor shall be deemed to have been waived and absolutely barred and the Nagar Nigam shall be discharged and released of all liabilities under the contract in respect of these claims.
- (f) The arbitration shall be conducted in accordance with the provisions of the Arbitration and Conciliation Act, 1996 (26 of 1996) or any statutory modifications or re-enactment thereof and the rules made there under and for the time being in force shall apply to the arbitration proceeding under this clause.
- (g) It is also a term of this contract that the arbitrator shall adjudicate on only such disputes as are referred to him by the appointing authority and give separate award against each dispute and claim referred to him and in all cases where the total amount of the claims by any party exceeds Rs. 1,00,000/- the arbitrator shall give reasons for the award.
- (h) It is also a term of the contract that if any fees are payable to the arbitrator, these shall be paid equally by both the parties.
- (i) It is also a term of the contract that the arbitrator shall be deemed to have entered on the reference on the date he issues notice to both the parties calling them to submit their statement of claims and counter statement of claims. The venue of the arbitration shall be such place as may be fixed by the arbitrator in his sole discretion. The fees, if any, of the arbitrator shall if required to be paid before the award is made and published, be paid half and half by each of the parties. The cost of the reference and of the award (including the fees, if any, of the arbitrator) shall be in the discretion of the arbitrator who may direct to any by whom and in what manner, such costs or any part thereof shall be paid and fix or settle the amount of costs to be so paid.

25.2 The arbitration shall be conducted in accordance with the arbitration procedure stated in the Special Condition of Contract Clause Nos. 4 and General Condition of Contract Clause Nos. 25.1 above.

## **26. Replacement of Dispute Review Expert.**

26.1 Not Applicable

## **27. Unauthorized occupation of building during construction**

It shall be the responsibility of the Contractor to see that the building under construction is not occupied by anybody unauthorisedly during construction, and is handed over to the Employer with vacant possession of complete building. If such building though completed is occupied illegally, then the Employer shall have the option to refuse to accept the said building/ buildings in that position. Any delay in acceptance on this account will be treated as the delay in completion and for such delay a levy up to 5% of tendered value of work may be imposed by the Employer whose decision shall be final both with regard to the justification and quantum and be binding on the Contractor.

However, the Employer, through a notice, may require the Contractor to remove the illegal occupation any time on or before construction and delivery.

## **28. Changes in firm's Constitution to be intimated**

Where the Contractor is a partnership firm, the previous approval in writing of the Engineer shall be obtained before any change is made in the constitution of the firm. Where the Contractor is an individual or a Hindu undivided family business concern such approval as aforesaid shall likewise be obtained before the Contractor enters into any partnership agreement where under the partnership firm would have the right to carry out the works hereby undertaken by the Contractor.

## **29. Electricity Supply required at the works**

### **29.1 Arrangement**

The Contractor shall make his own arrangement for electricity required for the work and nothing extra will be paid for the same.

### **29.2 Conditions**

- a) Distribution arrangements shall be done by the Contractor at his cost as per approved layout. He shall provide required clearances for overhead lines to facilitate easy movement of machinery. These overhead lines shall be shifted and rerouted at the Contractor's cost during execution of work if the same are found to obstruct any other work of any agency working at site or requires to be shifted due to unforeseen reasons.
- b) On completion of the Work, the Contractor shall, to the satisfaction of the Engineer, remove all wiring installed by him and make good, any disturbance or damage done.
- c) The Contractor shall employ a certified and licensed Electrician for carrying out this work.

## **30. Unfiltered water supply required for the work**

The Contractor shall make his own arrangements for water required for the work and nothing extra will be paid for the same. This will be subject to the following conditions:-

- (a) That the water used by the Contractor shall be fit for construction purposes to the satisfaction of the Employer.
- (b) The Employer shall make alternative arrangements for supply of water at the risk and cost of the Contractor if the arrangements made by the Contractor for procurement of water are in the opinion of the Employer, unsatisfactory.

## **31. Watching and Lighting**

The Contractor shall in connection with the Works, provide and maintain at his own cost all lights, guards, fencing and watching when and where necessary or as required by the Engineer or by any duly constituted authority, for the protection of the Works, or for the safety and convenience of the public or others.

## **B. TIME CONTROL**

### **32. Programme**

- 32.1. Within the time stated in the Contract Data the Contractor shall submit to the Engineer for Approval a programme showing the general methods, arrangements, Order and timing for all the activities in the Works along with monthly cash flow forecast.
- 32.2. An update of the programme shall be programme showing the actual programme achieved on each activity and the effect of the progress achieved on the timing of the remaining work including any changes to the sequence of the activities.
- 32.3. The Contractor shall submit to the Engineer, for approval, an updated programme at intervals no longer than the period stated in the Contract Data. If the Contractor does not submit an updated programme within this period, the Engineer may withhold the amount stated in the Contract Data from the next payment certificate and continue to withhold amount until the next payment after the date on which the over due programme has been submitted.
- 32.4. The Engineer's approval of the programme shall not alter the Contractor is obligations. The Contractor may revise the programme and submit it to the Engineer at any time. A revised programme is to show the effect of Variations and Compensation Events.

### **33. Extension of the Intended Completion Date.**

- 33.1. The Engineer shall extend the Intended Completion Date if a Compensation Event occurs or a Variation is issued which makes it impossible for completion to be achieved by the Intended Completion Date without the Contractor taking steps to accelerate the remaining work and which would cause the Contractor to incur additional cost.
- 33.2. The Engineer shall decide whether and by how much to extend the Intended completion data within 30 days of the contractor asking the Engineer for a decision upon the effect of a compensation Event or Variation and submitting full supporting information. If the contractor has failed to give early warning of or has failed to cooperate in dealing with a delay, the delay by this failure shall not be considered in assessing the new intended completion date.
- 33.3. The Engineer shall within 14 days of receiving full justification from the contractor for extension of Intended Completion Date refer to the Municipal Commissioner, Nagar Nigam Dehradun his decision. The Employer shall in not more than 21 days communicate to the Engineer the acceptance of otherwise of the Engineer's decision. If the Employer fails to give his acceptance, the Engineer shall not grant the extension and the contractor may refer the matter to the Dispute Review Expert under Clause Nos. 24.1.

### **34. Delays Ordered by the Engineer**

- 34.1 For execution of work the extended time be allowed in accordance with this condition shall be the essence of the contract. The execution of the work shall commence form such time period mentioned in schedule. If the contractor shall desire an extension of the time for completion of the work on the ground of his having been unavoidably hindered in its execution, or any other ground he shall apply in writing to the officer accepting the contract on behalf of the Government through the Engineer-in-charge

and a copy thereof is sent to Engineer-in-Charge within 30 days of hindrance on account of which he desires such extension as aforesaid. The cases of the extension of the time beyond the time schedule as per milestone shall be submitted to the authority next higher to the officer accepting the contract on behalf of the Government provided that the extension of time should be limited to 50% of the total period of that particular miles stone. In case this period exceeds more than – 50%, it shall be submitted to authority next to next higher to the office accepting the contract as the case may be.

34.2 The Engineer may instruct the Contractor to delay the start or progress of any activity within the Works.

**35. Early Warning**

35.1 The Contractor is to warn the Engineer at the earliest opportunity of specific likely future events or circumstances that may adversely affect the quality of the work increase the Contract Price or delays the execution of works. The Engineer may require the Contractor to provide and estimate of the expected effect of the future event or circumstances on the Contract Price and Completion Date. The estimate is to be provided by the Contractor as soon as reasonably possible.

35.2 The Contractor shall cooperate with the Engineer in making and consider proposals for how the effect of such an event circumstance can be avoided or reduced anyone involved in the work and in carrying out any resulting instruction of the Engineer.

## **C. QUALITY CONTROL**

### **36 Identifying Defects**

- 36.1. The Engineer shall check the Contractor's work and notify the Contractor of any Defects that are found. Such checking shall not affect the Contractor's responsibilities. The Engineer may instruct the Contractor to search for a Defect and to uncover and test any work that the Engineer considers may have a Defect.

### **37 Work to be open to inspection**

All works under or in the course of executive or executed in pursuance of the contract shall at all times be open to the inspection & supervision of the Engineer-in-Charge & his subordinates, & the contractor shall at all times during the usual working hours and at all other times, at which reasonable notice of intention of the Engineer-in-Charge or his subordinate to visit the works shall have been given to the contractor, either himself be present to receive order and instruction or have a responsible agent duly accredited in writing present for that purpose. Orders given to the contractor's agent shall be considered to have the same force as they had been given to the contractor himself.

### **38. Notice to be given before work is covered up**

The contractor shall not give less than five days, notice in writing to the Engineer-in-Charge before covering up or otherwise placing beyond the reach the measurement of any work in order that the same be measured and correct dimension thereof be taken before the same is so covered up or placed beyond the reach of measurement of any work without the consent in writing of the Engineer-in-Charge of the work & if the work shall be covered up or placed beyond the reach of measurement without such notice having been given or consent obtained, the same shall be uncovered at the contractor's expense, and in default thereof no payment or allowance shall be made for such work or the materials with which the same was executed.

### **39. Tests**

- 39.1. If the Engineer instructs the Contractor to carry out a test not specified in the specification to check whether any work has a Defect and the test shows that it does, the Contractor shall pay for the test and any samples, if there is no Defect the test shall be a Compensation Event.
- 39.2 Test laboratory and testing equipments required for the project should be available at site.

### **40. Correction of Defects**

- 40.1. The Engineer shall give notice to the Contractor of any Defects before the end of the Defects Liability Period, which begins at Completion and is defined in the Contract Data. The Defects Liability Period shall be extended for as long as Defects remain to be corrected.
- 40.2. Every time notice of a Defect is given, the Contractor shall correct the notified Defect within the length of time specified by the Engineer's notice.

### **41. Uncorrected Defects**

- 41.1. If the Contractor has not corrected a Defect within the time specified in the Engineer's notice, the Engineer will assess the cost of having the Defect corrected, and the Contractor will pay this amount.

**42. Action where no Specifications are specified**

In the case of any class of work for which there is no such specification, such work shall be carried out in accordance with the Bureau of Indian Standards Specifications. In case there is no such specification in Bureau of India Standards, the work shall be carried out as per manufacturer's specifications. In case there are no such specifications as required above, the work shall be carried out in all respects in accordance with the instructions and requirements of the Engineer.

## **D. COST CONTROL**

### **43. Bill of Quantities**

- 43.1. The Bill of Quantities shall contain items for the construction, installation, testing and commissioning work to be done by the Contractor.
- 43.2. The Bill of Quantities is used to calculate the Contract Price. The Contractor is paid for the quantity of the work done at the rate in the Bill of Quantities for each item.

### **44. Variations**

#### **44.1. Variation means:**

- (a) Increase or decrease in quantity of any work included in the Contract.
- (b) Omission of any such work (but not if the omitted work is to be carried out by the Employer by another contractor).
- (c) Additional work of any kind necessary for the completion of the Works.
- (d) Substitution of any item due to technical or administrative reasons.

#### **44.2 Variations in Quantities during Execution of work Contracts: The procedure detailed below shall be adopted for dealing with variations in quantities during execution of works contracts:**

44.2.1 Individual NS items in contracts shall be operated with variation of plus or minus 25% and payment would be made as per the agreement rate. For this, no finance concurrence would be required.

44.2.2 In case an increase in quantity of an individual item by more than 25% of the agreement quantity is considered unavoidable, the same shall be got executed by not practicable, quantity of that item may be operated in excess of 125% of the agreement quantity subject to the following condition:

- (a) Operation of an item by more than 125% of the agreement quantity needs the approval of an officer of the rank less than Municipal Commissioner, Nagar Nigam, Dehradun .
  - (i) Quantities operated in excess of 125% but upto 140% of the agreement quantity of the concerned item, shall be paid at 98% of the rate awarded for that item in that particular tender;
  - (ii) Quantities operated in excess of 140% but upto 150% of the agreement quantity of the concerned item shall be paid at 96% of the rate awarded for that item in that particular tender;
  - (iii) Variation in quantities of individual items beyond 150% will be prohibited and would be permitted only in exceptional unavoidable circumstances with the concurrence of associate finance and shall be paid at 96% of the rate awarded for that item in that particular tender.
- (b) The variation in quantities as per the above formula will apply only to the individual items of the contract and not on the overall contract value.
- (c) Execution of quantities beyond 150% of the overall agreemental value should not be permitted and, if found necessary, should be only through fresh tenders or by negotiating with existing contractor, with prior personal concurrence of Finance Controller and approval of Municipal Commissioner.

**Note:- Prior to the above that deviation's, the availability of funds should be ensured by the accepting officer that the total cost of the work does not exceed the sanctioned amount.**

44.3 In cases where decrease is involved during execution of contract:



- (a) The contract signing authority can decrease the items upto 25% of individual item without finance concurrence (if not banned).
  - (b) For decrease beyond 25% for individual items of 25% of contract agreement value, the approval of an officer not less than rank of Municipal Commissioner, Nagar Nigam Dehradun may be taken, after obtaining 'No Claim Certificate' From the contractor and with finance concurrence, giving detailed reasons for each such decrease in the quantities.
  - (c) It should be certified that the work proposed to the reduced will not be required in the same work.
- 44.4 The limit for varying quantities for minor value items shall be 100% (as against 25% prescribed for other items). A minor value item for this purpose is defined as an item whose original agreement value is less than 1% of the total original agreement value.
- 44.5 No such quantity variation limit shall apply for foundation items.
- 44.6 As far as SOR/DSR items are concerned, the limit of 25% would apply to the value of SOR/DSR schedule as whole and not on individual SOR/DSR items. However, in case of NS items, the limit of 25% would apply on the individual items irrespective of the manner of quoting the rate (single percentage rate or individual item rate).
- 44.7 The aspect of vitiation of tender with respect to variation in quantities should be checked and avoided. In case of vitiation of the tender (Both for increase as well as decrease of value of contract agreement), sanction of the competent authority as per single tender should be obtained.

**Note: The Quantity of the same items, which has not been banned by the tender committee may be decrease or increased the items.**

- 44.8 During the execution of the work, the quantities of the proposed Extra/substitute items will be executed as per the following procedures:-
- 44.8.1 Individual Extra/substitute item upto 01% of the initial/original contract agreement cost can be accepted Project Manager.
  - 44.8.2 Individually Extra/substitute item upto 03% of the initial/original contract agreement cost can be accepted by Municipal Commissioner, Nagar Nigam Dehradun.
  - 44.8.3 Individually Extra/substitute item upto 05% of the initial/original contract agreement cost can be accepted by Chief Municipal Commissioner, Nagar Nigam Dehradun (Project).
  - 44.8.4 Individually Extra/substitute item upto 10% of the initial/original contract agreement cost can be accepted by Managing Director.

**Note:-**

- (i) Before accepting the above procedure (1-4) the availability of funds should be ensured by accepting officer so the total cost of the work is not more than the sanctioned cost.
- (ii) Valid reason is required to be submitted for proposing any Extra/substitute items.
- (iii) The Rates of extra items will be calculated according to the current SOR/DSR/current Market rate.

**45. Payments for Variations – As per clause Nos. 44.**

**46. Cash Flow Forecasts**

- 46.1. When the Programme is updated, the contractor is to provide the Engineer an updated cash flow forecast.

## **47. Payment Certificates**

- 47.1 The contractor shall submit to the Engineer monthly (bill) in the departmentally issued printed form statements of the estimated value of the works completed less the cumulative amount certified previously.
- 47.2 The Engineer shall check the contractor's monthly statement within 14 days and certify the amount to be paid the contractor after taking into account any credit or debit for the month in question in respect of materials for the relevant amounts and under conditions set forth in sub- clause 57.4 of the contract data.
- 47.3. The value of the works executed shall be determined by the Engineer.
- 47.4. The value of work executed shall comprise the value of the quantities of the items in the Bill of Quantities completed.
- 47.5 The value of work executed shall include the valuation of Variations.
- 47.6. The Engineer may exclude any item certified in a previous certificate or reduce the proportion of any item previously certified in any certificate in the light of later information.

## **48. Payments**

### **48.1 Measurement of Work Done**

- (a) Engineer shall, except as otherwise provided, ascertain and determine by measurement the value in accordance with the Contract of work done.
- (b) All measurements of all items having financial value shall be entered in Measurement Book and/or level field Book so that complete record is obtained of all works performed under the Contract.
- (c) All measurements and levels shall be taken jointly by the Engineer or his authorized representative and by the Contractor or his authorized representative from time to time during the progress of the work and such measurements shall be signed and dated by the Engineer and the Contractor or their representatives in token of their acceptance. If the Contractor objects to any of the measurements recorded, a note shall be made to that effect with reason and signed by both the parties. Any measurement taken by the Engineer in the presence of the Contractor or in his absence after due notice has been given to him in consequence of objection made by the Contractor shall be final and binding on the Contractor, and no claim whatsoever shall thereafter be entertained regarding the accuracy and classification of the measurement.
- (d) If for any reason the Contractor or his authorized representative is not available and the work of recording measurements is suspended by the Engineer or his representative, the Engineer shall not entertain any claim from the Contractor for any loss or damages on this account. If the Contractor or his authorized representative does not remain present at the time of such measurements after the Contractor or his authorized representative has been given a notice in writing three (3) days in advance or fails to countersign or to record objection within a week from the date of the measurement, then such measurements recorded in his absence by the Engineer or his representative shall be deemed to be accepted by the Contractor.
- (e) The Contractor shall, without extra charge, provide all assistance with

every appliance, labour and other things necessary for measurements and recording levels.

- (f) Except where any general or detailed description of the work expressly shows to the contrary, measurements shall be taken in accordance with the procedure set forth in the specifications notwithstanding any provision in the relevant Standard Method of measurement or any general or local custom. In the case of items which are not covered by specifications, measurements shall be taken in accordance with the relevant standard method of measurements issued by the Bureau of Indian standards and if for any item no such standard is available, then a mutually agreed method shall be followed.
- (g) The Contractor shall give not less than seven days' notice to the Engineer or his authorized representative in charge of the work before covering up or otherwise placing beyond the reach of measurement any work in order that the same may be measured and correct dimensions thereof be taken before the same is covered up or placed beyond the reach of measurement and shall not cover up and place beyond reach of measurement any work without consent in writing of the Engineer or his authorized representative in charge of the work who shall within the aforesaid period of seven days inspect the work, and if any work shall be covered up or placed beyond the reach of measurements without such notice having been given or the Engineer consent being obtained in writing, the same shall be uncovered at the Contractor's expense, or in default thereof no payment or allowance shall be made for such work or the materials with which the same was executed.
- (h) Employer or his authorized representative may cause either themselves or through another officer of the Employer to check the measurements recorded jointly or otherwise as aforesaid and all provisions stipulated herein above shall be applicable to such checking of measurements or levels.
- (i) It is also a term of this Contract that recording of measurements of any item of work in the measurement book and/ or its payment in the interim, on account or final bill shall not be considered as conclusive evidence as to the sufficiency of any work or material to which it relates nor shall it relieve the Contractor from liabilities from any over measurement or defects noticed till completion of the defects liability period.

48.2 Payments shall be adjusted for deductions for advance payments, retention, other recoveries in terms of the contract and taxes at source, as applicable under the law. The Employer shall pay the Contractor the amounts certified by the Engineer within 28 days of the date of each certificate.

48.3 If an amount certified is increased in a later certificate as a result of an award by the Adjudicator or an Arbitrator, the Contractor shall be paid interest upon the delayed payment as set out in this clause. Interest shall be calculated from the date upon which the increased amount would have been certified in the absence of dispute.

48.4 Items of the Works for which no rate or price has been entered in will not be paid for by the Employer and shall be deemed covered by other rates and prices in the Contract.

#### **49. Tax**

49.1. The rates quoted by the Contractor shall be deemed to be inclusive of the sales and all other taxes that the Contractor will have to pay for the performance of this Contract. The Employer will perform such duties in regard to the deduction of such taxes at source as per applicable law. The GST shall be claimed by the contractor in their bills & paid as per Govt. rules.

#### **50. Currencies**

50.1. All payments shall be made in Indian Rupees (INR).

#### **51. Price Adjustment- Deleted.**

#### **52. Retention (Security Deposit)-**

52.1. The Employer shall retain from each payment due to the Contractor the proportion stated in the Contract Data until Completion of the whole of the Works.

52.2. On Completion of the whole of the works, the total amount retained is repaid to the contractor when the Defects Liabilities period has passed and the Employer has certified that all Defects notified to the Contractor before the end of this period have been corrected.

52.3. On Completion of the whole works, contractor may substitute retention money with an “on demand” bank guarantee.

#### **53. Liquidated Damages/ Compensation for Delay**

53.1 The Contractor shall pay liquidated damages to the Employer at the rate per week stated in the Contract Data for week day that the Completion Date is later than the Intended Completion Date (for the whole of the works or the milestone as stated in the contract data). The total amount of liquidated damages shall not exceed the amount defined in the Contract Data. The Employer may deduct liquidated damages from payments due to the Contractor. Payment of liquidated damages does not affect the Contractor’s liabilities.

53.2. If the Intended Completion Date is extended after liquidated damages have been paid, the Engineer shall correct any overpayment of liquidated damages by the Contractor by adjusting the next payment certificate.

53.3 The payment or deduction of such damages shall not relieve the contractor from his obligation to complete the works or from any other of his obligations and liabilities under the contract.

#### **54. Advance Payment**

54.1 The Contractor is to use the advance payment only to pay for Equipment, Plant, Materials, and mobilization expenses required specifically for execution of the Contract. The Contractor shall demonstrate that advance payment has been used in this way by supplying copies of invoices or other documents to the Engineer.

54.1 The recovery of mobilization advance shall start from bill after the work done exceeds 10% of the initial contract price or three months from the date of payment of advance whichever period concludes earlier and shall be made at the rate of 15% of the work done in each running bill. The recovery of advance shall be completed when 90% of the work has been completed or prior to the expiry of original time for

completion whichever is earlier. No account shall be taken of the advance payment or its repayment in assessing valuations of work done, Variations, price adjustments, Compensation Events, Bonuses, or Liquidated Damages.

## **55. Securities**

55.1 The Performance Security/ Performance Guarantee (including additional security for unbalanced bids) shall be provided to the Employer no later than the date specified in the Letter of Acceptance and shall be issued in an amount and form and by a bank or surety acceptable to the Employer, and denominated in Indian Rupees. The Performance Security/ Performance Guarantee shall be valid until a date 60 days from the date of issue of the certificate of completion/ extended date of completion (if any).

## **56. Payment terms**

- 56.1: The payment schedule for the supply, installation, testing and commissioning of items will be as under:
- a. On supply/delivery of items in good condition at site (which comply with the specifications of items): 50% of the BOQ rate.
  - b. On installation/fixing and testing & commissioning: remaining 50% of the BOQ rate.

## **57. Cost of Repairs**

57.1 Loss or damage to the Works or Materials to be incorporated in the Works between the Start Date and the end of the Defects Correction periods shall be remedied by the Contractor at the Contractor's cost if the loss or damage arises from the Contractor's acts or omissions.

## **58. Royalty Payable on minor minerals – Employer to be indemnified.**

Where the State Government has enacted any legislation to the effect that the user of minor minerals such as red bajri, stone, kankar etc., will be responsible to ensure that for the minerals used in the work, the quarry operator extracting the minerals has paid royalty as due to the State Government, before any Bill is paid to the Contractor, the Contractor should furnish a declaration to the Employer confirming that royalty as due has been paid to the State Government for the minerals used in the works. The Contractor should also indemnify the Employer against any legal action that may be instituted against the Employer by the State Government consequent on violation of the provisions in the relevant Act by the Contractor.

## **59. Production of vouchers etc by the Contractor**

- (a) The Contractor shall, whenever required produce or cause to be produced for examination by the Engineer any quotation, invoice, cost or other account, book of accounts, voucher, receipt, letter, memorandum, paper of writing or any copy of or extract from any such document and also furnish information and returns verified in such manner as may be required in any way relating to the execution of this Contract or relevant for verifying or ascertaining cost of execution of this Contract and the decision of the Engineer on the question of relevancy of any documents, information or return being final and binding on the parties. The Contractor shall similarly produce vouchers etc. if required to prove to the Engineer that the materials supplied by him, are in accordance with the specifications laid down in the Contract.
- (b) If any portion of the work in a Contract is being carried out by a Sub Contractor or any subsidiary or allied firm or Company in terms of permission granted

under Clause 7 of Contract, the Engineer shall have power to secure the book of such sub Contractor or any subsidiary or allied firm or company through the Contractor and such book shall be open to the Engineer's inspection.

- (c) The obligations imposed by sub clause (a) and (b) above are without prejudice to the obligations of the Contractor under any statute, rules or orders binding on the Contractor.

## **E. FINISHING THE CONTRACT**

### **60. Completion**

- 60.1. The Contractor shall request the Engineer to issue a Certificate of Completion of the Works and the Engineer will do so upon deciding that the Work is completed
- 60.2. Within fifteen days of the receipt of the notice, the Engineer-in-Charge shall inspect the work and if there is no visible defect on the face of the work, shall give the contractor a certificate of completion. If the Engineer-in-charge finds that the work has been fully completed, it shall be mentioned in the certificate to be granted. On the other hand, if it is found that there are certain visible defects to be removed, the certificate to be granted by Engineer-in-charge shall specifically mention the details of the visible defects along with the estimate of the cost for removing these defects. The final certificate of completion of work shall be given after the visible defects pointed out as above have been removed.

### **61. Taking Over**

- 61.1. The Client shall take over the Site and the Works within One month of the Engineer issuing a certificate of Completion, from the Contractor in the presence of the Employer.

### **62. Final Account (Final Bill)**

- 62.1. The Contractor shall supply to the Engineer a detailed account of the total amount that the Contractor considers payable under the Contract before the end of the Defect Liability Period. The Engineer shall issue a Defect Liability Certificate and certify any final payment that is due to the Contractor within 56 days of receiving the contractor's account if it is correct and complete. If it is not, the Engineer shall issue within 56 days a schedule that states the scope of the corrections or additions that are necessary. If the Final Account is still unsatisfactory after it has been resubmitted, the Engineer shall decide on the amount payable to the Contractor and issue a payment certificate, within 56 days of receiving the Contractor's revised account.

### **63. Operating and Maintenance Manuals**

- 63.1. If "as built" Drawings and/or operating and maintenance manuals are required the Contractor shall supply them by the dates stated in the Contract Data.
- 63.2. If the Contractor does not supply the Drawings and/or manually by the date stated in the Contract Data, or they do not receive the Engineer's approval, the Engineer shall withhold the amount stated in the Contract Data from payments due to the Contract

### **64. Termination**

- 64.1. The Employer or the Contractor may terminate the Contract if the other party causes a fundamental breach of the Contract.
- 64.2. Fundamental breaches of Contract include, but shall not be limited to the following:
  - (a) The Contractor stops work for 28 days when no stoppage of work is shown on the current Programme and the stoppage has not been authorized the Engineer.
  - (b) The Engineer instructs the Contractor to delay the progress of the work and the instruction is not withdrawn within 28 days;
  - (c) The Employer or the Contractor is made bankrupt or goes into liquidation other than for a reconstruction or amalgamation.

- (d) A payment certified by the Engineer is not paid by the Employer to Contractor with 56 days of the date of Engineer's certificate;
- (e) The Engineer gives notice that failure to correct a particular Defect is a fundamental breach of Contract and the Contractor fails to correct it was a reasonable period of time determined by the Engineer.
- (f) The contractor does not maintain a security which is required.
- (g) The contractor has delayed the completion of works by the number of days which the maximum amount of liquidated damages can be as defined on the Contract data and
- (h) If the Contractor, in the judgment of the Employer has engaged in corrupt or fraudulent practices in competing for or in executing the Contract.

For the purpose of this paragraph: "corrupt practice means the offering, giving, receiving or soliciting of any thing of value to influence the action of a public official in the procurement process or in contract execution. "Fraudulent practice" means a misrepresentation of facts in order to influence a procurement process or the execution of a contract to the detriment of the Borrower, and includes collusive practice among Bidders (prior to or after bid submission) designed to establish bid prices at artificial non-competitive levels and to deprive the Borrower of the benefits of free and open competition."

- 64.3 When either party to the Contract gives notice of a breach of contract to the Engineer for a cause other than those listed under Sub Clause 64.2 above, the Engineer shall decide whether the breach is fundamental or not.
- 64.4. Notwithstanding the above, the Employer may terminate the Contract for convenience.
- 64.5. If the Contract is terminated, the Contractor shall stop work immediately, make the Site safe and secure and leave the Site as soon as reasonably possible.

**65. Payment upon Termination**

- 65.1. If the Contract is terminated because of a fundamental breach of Contract by the Contractor, the Engineer shall issue a certificate for the value of the work done less advance payments received up to the date of the issue of the certificate, less other recoveries due in terms of the contract, less taxes due to be deducted at source as per applicable law and less the percentage to apply to the work not completed as indicated in the Contract Data. Additional Liquidated Damages shall not apply. If the total amount due to the Employer exceeds any payment due in the Contractor the difference shall be a debt payable to the Employer.
- 65.2. If the Contract is terminated at the Employer's convenience or because of fundamental breach of Contract by the Employer, the Engineer shall issue a certificate the value of the work done, the cost of balance material brought by the contractor for as available as site. The reasonable cost of removal of Equipment, repatriation of the Contract personnel employed solely on the works, and the Contractor's costs of protecting and security the profit and less advance payments received up to the date of the certificate, less other recoveries due in terms of the contract and less taxes due to be deducted at sources as per applicable law.



## **66. Property**

66.1. All materials on the Site. Plant, Equipment, Temporary works and works deemed to be the property of the Employer, if the Contract is terminated because Contractor's default.

## **67. Foreclosure of Contract due to Abandonment or Reduction in Scope of Work**

67.1 If at any time after acceptance of the tender the Employer shall decide to abandon or reduce the scope of the works for any reason whatsoever and hence not require the whole or any part of the works to be carried out, the Engineer shall give notice in writing to that effect to the Contractor and the Contractor shall act accordingly in the matter. The Contractor shall have no claim to any payment of compensation or otherwise whatsoever, on account of any profit or advantage which he might have derived from the execution of the works in full but which he did not derive in consequence of the foreclosure of the whole or part of the works.

67.2 The Contractor shall be paid at the rates as stipulated in Clause 46 for works executed at site and, in addition, a reasonable amount as certified by the Engineer whose decision shall be final and binding on the Contractor, for the items hereunder mentioned which could not be utilized on the work to the full extent in view of the foreclosure:

- (a) Any expenditure incurred on preliminary site work, e.g. temporary access roads, temporary labour huts, staff quarters and site office, storage accommodation and water storage tanks.
- (b) The Employer shall have the option to take over Contractor's materials or any part thereof either brought to site or of which the Contractor is legally bound to accept delivery from suppliers (for incorporation in or incidental to the work) provided, however, the Employer shall be bound to take over the materials or such portions thereof as the Contractor does not desire to retain. For materials taken over or to be taken over by the Employer cost of such materials as detailed by Engineer shall be paid. The cost shall, however, take into account purchase price, cost of transportation and deterioration or damage which may have been caused to materials whilst in the custody of the Contractor.
- (c) If any materials supplied by the Employer are rendered surplus, the same except normal wastage shall be returned by the Contractor to the Employer at rates not exceeding those at which these were originally issued less allowance for any deterioration or damage which may have been caused whilst the materials were in the custody of the Contractor. In addition, cost of transporting such materials from site to the Employer's stores, if so required by the Employer shall be paid.
- (d) Reasonable compensation for transfer of T & P from site to Contractor's permanent stores or to his other works, whichever is less. If T & P are not transported to either of the said places, no cost of transportation shall be payable.
- (e) Reasonable compensation for repatriation of Contractor's site staff and imported labour to the extent necessary.

67.3 The Contractor shall, if required by the Engineer furnish to him books

of account, wage books, time sheets and other relevant documents and evidence as may be necessary to enable him to certify the reasonable amount payable under this condition.

- 67.4 The reasonable amount of items on 67.2 (a), 67.2 (d), & 67.2 (e) above shall not be in excess of 2% of the cost of the work remaining incomplete on the date of closure, i.e. total stipulated cost of the work as per accepted tender less the cost of work actually executed under the Contract and less the cost of Contractor's materials at site taken over by the Employer as per item (ii) above. Provided always that against any payments due to the Contractor on this account or otherwise, the Employer shall be entitled to recover or be credited with any outstanding balances due from the Contractor for advance paid in respect of any tool, plants and materials and any other sums which at the date of termination were recoverable by the Employer from the Contractor under the terms of the Contract.

**68. Termination of Contract on death of Contractor**

Without prejudice to any of the rights or remedies under this Contract if the Contractor dies, the Engineer on behalf of the Employer shall have the option of terminating the Contract without compensation to the Contractor.

**69. Work to be Carried out on Risk & Cost**

- 69.1 Action when whole of Security Deposited is forfeited:

The Officer accepting the Contract on behalf of the Corporation or the Engineer-in-charge shall have the power, without prejudice to his right against the contractor in respect of any delay or inferior workmanship or otherwise or to any claims for damage in respect of any items of the contract and without prejudice to any rights or remedies under any of the provisions of this contract or otherwise whether the date for completion has or has not been extended, by a notice in writing; to determine the contract in any of the following cases:

- (a) If the Contractor having been given by the Engineer-in-Charge a notice in writing (Which notice under the hand of the Engineer-in-Charge or Communicated through the Resident Engineer shall be conclusive evidence) to rectify, reconstruct or replace any defective work or any work damaged by any reason whatsoever or that the work is being performed in any inefficient or otherwise improper or un-workman like manner, shall fail to comply with the requirements within a period of seven days of such notice or if the contractor shall delay or suspend the execution of the work so that either in the judgment of the Engineer-in-Charge (which shall be final & binding) he will be unable to secure completion of the work by the due date for completion or he has already failed to complete the work by that date.
- (b) If the contractor being a company shall pass a resolution of the court/ shall make an order that the company shall be wound up or if a receiver or a manager on behalf of creditor shall be appointed or of the circumstances shall arise which entitled the court or creditor to appoint a Receiver or Manager or which entitle the court to make winding up in order.
- (c) If the contractor commits breach of any of the terms and conditions of this contract other than those mentioned in Sub-Clause (a) above.

- 69.2 When the contractor has made himself liable for action under any of the cases aforesaid, the officer accepting the contract on behalf of the Municipal Commissioner, Nagar Nigam Dehradun or the Engineer-in-Charge shall have power

to adopt any one or more of the following courses as he may decide best suited to the interest of the Corporation.

- (a) To determine or rescind the contract as aforesaid (of which the termination or rescission notice in writing to the Contractor under the hand of the Engineer-in-Charge, shall be conclusive evidence). Upon such determination, or rescission the security deposit of the contractor shall be liable to be forfeited and shall be absolutely at the disposal of the Company.
- (b) To employ labour paid by Municipal Commissioner, Nagar Nigam Dehradun and to supply materials to carry out the works or any part thereof by debiting the contractor with the cost of the labour and the price of the materials (of the amount of which cost & Price Certificate under the hand of the Project Manger and communicated through the Engineer-in-charge/ Resident Engineer shall be final and conclusive against the contractor) & crediting him with the value of the work done in all respects in the same manner and at the same rates as if it had been carried out by the contractor under the terms of his contract. The certificate of the Engineer-in-Charge as to the value of the work done shall be final and conclusive against the contractor, provided always that action under this Sub-clause shall only be taken after giving notice in writing to the Contractor. Provided also that if the expenses incurred by the department are less than the amount payable to the Contractor at his agreement rates; the difference **shall not be paid** to the contractor.
- (c) After giving notice to the Contractor to cause to measure up the work of the Contractor & to take such part thereof as shall be unexecuted out of his hands and to give it to, another Contractor to complete in which case any expenses which may be incurred in excess of the sum which would have been paid to the original contractor if the whole work had been executed by him (for the amount of such excess the Certificate in writing of the Engineer-in-Charge shall be final & Conclusive) shall be borne and paid by the Original Contractor any may be Deducted from any money due to him by the Corporation under this Contract or any other account whatsoever or from his security deposit or the proceeds of sales thereof for a sufficient part thereof as the case may be.

69.3 In the event of any one or more of courses mentioned in the Sub-Clauses 72.2 above being adopted by the Engineer-in-Charge the Contractor shall have no claim to compensation for any loss sustained by him by reason of his having purchased or procured any materials or entered into any agreement or made any advances or with a view to the execution of the work or the performance of contract. And in case action is taken under any of the provisions aforesaid, the contractor shall not be entitled to recover or be paid any sum for any work thereof actually performed under this contract unless and until the Engineer-in-Charge has Certified in writing the performance of such work and the value payable in respect thereof and he shall only be entitled, to be paid the value so certified.

## **70. Release from Performance**

70.1. If the Contract is frustrated by the out break of war or by any other event outside the control of either the Employer or the Contractor the Engineer shall certify the Contract has been frustrated. The Contractor shall make the Site safe and stop work quickly as possible after receiving this certificate and shall be paid for all work carried before receiving it and for any work carried out afterwards to which commitment was made.

## **SPECIAL CONDITIONS OF CONTRACT**

### **1. Labour:**

The Contractor shall unless otherwise provided in the Contract, make his own arrangements for the engagement of all staff and labor local or other, and for their payments housing, feeding and transport.

The Contractor shall, if required by the Engineer, deliver to the Engineer a return in detail, in such form and at such intervals as the Engineer may prescribe, showing the staff and the numbers of the several classes of labour from time to time employed by the Contractor on the Site and such other information as the Engineer may require.

### **2. Compliance with Labour Regulations:**

During continuance of the contract, the Contractor and his sub contractors shall abide at all times by all existing labour enactments and rules made there under, regulation notifications and bye laws of the State or Central Government or local authority and other labour law (including rules), regulations, bye laws that may be passed or notifications that may be issued under any labour law in future either by the State or the Center Government or the local authority Salient features of some of the major labour laws are applicable to construction industry are given below. The contractor shall keep Employer indemnified in case any action is taken against the Employer by the competent authority on account of contravention of any of the provisions of any Act or rules made there-under regulations or notifications including amendments. If the Employer is caused to pay or reimburse, such amounts as pay be necessary to cause or observe, or for non observance of the provisions stipulated in the notification/ bye laws/ Acts/ Rules/Regulations. Including amendments if any on the part of the contractor, the Engineer/Employer shall have the right to deduct any money due to the Contractor is paying his amount of performance security. The Employer/Engineer shall also have right to recover from the Contractor any sum required or estimated to be required for making good the loss or damages suffer by the Employer.

The employees of the Contractor and the Sub Contractor in no case shall be treated as the employees of the Employer at any point of time.

### **3. Salient features of some major labour laws applicable to establishment engaged in building and other construction work.**

- (a) **Workmen Compensation Act. 1923:-** The Act provides for compensation in case of injury by accident arising out of and during the course of employment.
- (b) **Payment of Gratuity Act 1972:** - Gratuity is payable to an employee under the Act on satisfaction of certain conditions on separation if an employee has completed 5 years service or more on death, the rate of 15 days wages for every completed year of service. The Act is applicable to all establishment employing 10 or more employees.
- (c) **Employees P.F. and Miscellaneous Provisions Act. 1952:** - The Act Provides for monthly contributions by the employer plus workers @ 10% or 8.33%. The benefits payable under the act are :-
  - ii) Pension or family pension on retirement or death as the case may be
  - iii) Deposit linked insurance on the death in harness of the worker.
  - iv) Payment of PF accumulation on retirement/death etc.
- (d) **Maturity Benefit Act 1951:** - The Act provides for leave and some other benefits to women employees in case of confinement or miscarriage etc.

- (e) **Contract Labour (Regulation & Abolition) Act 1979:** - The Act provides for certain welfare measures to be provided by the contractor to contract labour and in case the Contractor fails to provide, the same are required to be provided, by the Principal Employer by Law. The Principal Employer is required to take Certificate of Registration and the Contractor is required to take license from the designated Officer. The Act is applicable to the establishment or Contractor of Principal Employer, if they employ 20 or more contract labour.
- (f) **Minimum Wages Act 1948:** - The Employer is supposed to pay not less than the minimum wages fixed by appropriate Government as per provisions of the Act if the employment is a scheduled employment Construction Buildings, Road, Runways are scheduled employments.
- (g) **Payment of Wages Act 1936:** - It lays down as to by what date the wages are to be paid, when it will be paid and what deductions can be made from the wages of the workers.
- (h) **Equal Remuneration Act 1979:** - The Act provides of equal wages for work of equal nature to Male and Female workers and for not making discrimination against Female employees in the matters of transfers, training and promotions etc.
- (i) **Payment of Bonus Act 1965:** - The Act is applicable to all establishment employing 20 or more employees. The Act provides for payments of annual bonus subject to a minimum of 8.33% of wages and maximum of 20% of wages to employees drawing Rs. 3500/- per month or less. The bonus to be paid to employees getting Rs. 2500/- per month or above up to Rs. 3500/- per month shall be worked out by taking wages as Rs. 2500/- per month only. The Act does not apply to certain establishments. The newly setup establishment are exempted for five years in certain circumstances. Some of the State Governments have reduced the employment size from 20 to 10 for the purpose of applicability of this Act.
- (j) **Industrial Disputes Act 1947:** - The Act lays down the machinery and procedure for resolution of Industrial disputes, in what situations a strike or lock-out becomes illegal and what are the requirements for laying off or retrenching the employees or closing down the establishment.
- (k) **Industrial Employment (Standing Orders) Act 1946:** - It is applicable to all establishments employing 100 or more workmen (employment size reduced by some of the States and Central Government to 50). The Act provides to laying down governing the conditions of employment by the Employer on matters provided in the Act and get the same certified by the designated Authority.
- (l) **Trade Unions Act 1926:** - The Act lays down the procedure for registration of trade unions of workmen and employers. The Trade Unions registered under the Act have been given certain immunities from civil and criminal liabilities.
- (m) **Child Labour (Prohibition & Regulation) Act 1986:** - The Act prohibits employment of children below 14 years of age in certain occupations and processes and provides for regulation of employment of children in all other occupation and processes. Employment of Child labour is prohibited on Building and Construction Industries.
- (n) **Inter-State Migrant workmen's (Regulation of Employment & Conditions of Services) Act 1979:** - The Act is applicable to an establishment which employees five or more inter-state migrant workmen through intermediary (who has recruited workmen in one state for employment in the establishment/ situated in another state). The Inter-State migrant workmen, in an establishment to which this Act becomes applicable, are required to be provided certain facilities such as housing, medical aid, traveling expenses from home, up to the establishment and bank etc.

- (o) **The Building and Other Construction workers (Regulation of Employment and Conditions of Service) Act 1996 and the Cess Act of 1996:** - All the establishment who carry on any building or other constructions works and employer 10 or more workers are covered under this Act. All such establishment are required to pay cess at the rate not exceeding 2% of the cost of construction as may be modified by the Government. The Employer of the establishment is required to provide safety measures at the Building or constructions work and other welfare measures, such as Canteens, First-Aid facilities, Ambulance, Housing accommodations for workers near the work place etc. The employer to whom the Act applies has to obtain a registration certificate from the Registering Officer appointed by the Government.
- (p) **Factories Act 1948:** - The Act lays down the procedure for approval of plans before setting up a factory, health and safety provisions; welfare provisions, working hours, annual earned leave and rendering information regarding accidents or dangerous occurrences to designated authorities. It is applicable to premises employing 10 persons or more with aid of power of 20 or more persons without the aid of power engaged in manufacturing process.
- (q) **Noise and Disturbance:-** All Works shall be carried out without unreasonable noise and disturbance. The Contractor shall indemnify and keep indemnified the Employer from and against any liability for damages on account of noise or other disturbance created while or in carrying out the Works and from and against all claims, demands, proceedings, damages, costs, changes and expenses whatsoever in regard or in relation to such liability.
- (r) **Pollution**  
 The Contractor shall take all reasonable steps to protect the environment (both on and off the site) to avoid adverse impacts, limit the damage and nuisance to people and property resulting from pollution, noise and other results of his operations. The Contractor shall insure the emissions, surface discharges and effluents from Contractor's activities shall not exceed values stated in the Specifications or prescribed by applicable Laws.  
 Subject and without prejudice to any other provision of the Contract and the law of the land and its obligations as applicable the Contractor shall take all reasonable precaution.
- a) Procurement and renewal of the NOC from State Pollution Control Board, till the expiry of the Contract will be the sole responsibility of the Contractor. The Employer shall be indemnified against any claim arising out of non-obtaining of the NOC by the Contractor.
- b) Procurement and renewal of the NOC from Jal Nigam/ Nalkoop Nigam for boring etc., till the expiry of the Contract will be the sole responsibility of the Contractor. The Employer shall be indemnified against any claim arising out of non-obtaining of the NOC by the Contractor.
- c) Procurement and renewal of the NOC from the Department of Geology and Mines, till the expiry of the Contract will be the sole responsibility of the Contractor. The Employer shall be indemnified against any claim arising out of non-obtaining of the NOC by the Contractor.
- d) in connection with rivers, streams, waterways, drains, water-courses, lakes, reservoirs and the like to prevent:
- i) Silting:
  - ii) Erosion of their beds or banks: and
  - iii) Pollution of the water so as to affect adversely the quality or appearance thereof of cause injury or death to animal and plant life.

- e) in connection with underground water resources including percolating water to prevent:
  - i) Any interference with the supply to or obstruction from such sources; and
  - ii) Pollution of the water so as to affect adversely the quality thereof.
- (s) **The Apprentices Act 1961:-** The Contractor shall duly comply with the provisions of the Apprentices Act 1961 (III of 1961) the rules made there under word and any order that may be issued from time to time under the said Act and the said Rules and on his failure or neglect to do so be shall be subject to all liabilities and penalties provided by the said Act and the said rules.
- (t) **Details to be Confidential:-** The Contractor shall treat the details of the Contract as private and confidential, save insofar as may be necessary for the purposes thereof, and shall not publish or disclose the same or any particulars thereof in any trade or technical paper or elsewhere without the previous consent in writing of the Employer. If any dispute arises as to the necessity of any publication or disclosure for the purpose of the Contract the same shall be referred to the Employer whose determination shall be final.
- (u) **Life-Saving Appliances and First-Aid Equipment:-** The Contractor shall provide and maintain upon the Works and the Site sufficient, proper and efficient life-saving appliances and first-aid equipment to the approval of the Engineer and in accordance with the requirements of ILO Convention Nos. 62. The appliances and equipment shall be available for use at all times during the Contract Period.
- (v) **Customs and Security Requirements:-** The Contractor shall comply with all regulations for the time being imposed by the Customs and Security Authorities in respect of the passage of Plant, vehicle, materials and personnel through Customs barriers.
- (w) **Indemnification:-** The Contractor shall keep the Employer both during and after the term of this Contract fully and effectively indemnified against all losses, damages, injuries, deaths, expenses, actions, proceedings, demands, costs and claims including, but not limited to, legal fees and expenses, suffered by Employer, where such loss, damages, injury or death is the direct result of the wrongful action, negligence, or breach of Contract of the Contractor or their sub-contractors, or the personnel or agents of either of them, including the use or violation of any statutory regulations, laws in vogue in the Employer's country.
- (x) **Generic Environmental Management and Monitoring Plan:-** Environmental Management and Monitoring Plan (EMP) is the key to ensure a safe and clean environment. The desired results from the environmental mitigation measures proposed in the project may not be obtained without a management plan to assure its proper implementation and function. The EMP envisages the plans for the proper implementation of mitigation measures to reduce the adverse impacts arising out of the project activities.
- (y) **Social Liability**
  - (i) The Contractor shall bear the cost of any impact on structure or land due to movement of machinery during construction.
  - (ii) All temporary use of lands outside ROW to be through written approval of Landowner.
  - (iii) Location of construction camps to be set up in consultation with PWD.
- (z) **HIV-AIDS Awareness and Prevention**
  - (a) The Contractor shall conduct an HIV-AIDS awareness programme via an approved service provider or specialized NGO, and shall undertake such other measures as are specified in this Contract to reduce the risk of the transfer of the

HIV virus between and among the Contractor's Personnel and the local community, to promote early diagnosis and to assist affected individuals. The Contractor shall throughout the contract: (i) conduct Information, Education and Consultation Communication (IEC) campaigns, at least every other month, addressed to all the Site staff and labor (including all the Contractor's employees, all Sub-Contractors and Consultants' employees working on the Site, and truck drivers and crew making deliveries to the Site for Works and Services executed under the contract, and to the immediate local communities, concerning the risks, dangers and impact, and appropriate avoidance behavior with respect to of Sexually Transmitted Diseases (STD)—or Sexually Transmitted Infections (STI) in general and HIV/AIDS in particular; (ii) provide male or female condoms for all Site staff and labor as appropriate; and (iii) provide for STI and HIV/AIDS screening, diagnosis, counseling and referral to a dedicated national STI and HIV/AIDS program, (unless otherwise agreed) of all Site staff and labor.

(b) The Contractor shall include in the program to be submitted for the execution of the Works and Services under Sub-Clause 17 a program for Site staff and labour and their families in respect of Sexually Transmitted Infections (STI) and Sexually Transmitted Diseases (STD) including HIV/AIDS. The STI, STD and HIV/AIDS alleviation program shall indicate when, how and at what cost the Contractor plans to satisfy the requirements of this Sub-Clause and the related specification. For each component, the program shall detail the resources to be provided or utilized and any related sub-contracting proposed. The program shall also include provision of a detailed cost estimate with supporting documentation. Payment to the Contractor for preparation and implementation this program shall not exceed the Provisional Sum dedicated for this purpose.

(aa) **Removal of staff:-** If the Engineer or his Representative asks the Contractor to remove a person who is a member of the Contractor's staff or work force, stating the reasons, the Contractor shall ensure that the person leaves the Site within seven days and has no further connection with the work in the Contract.

It will be the sole responsibility of the Contractor to replace the removed person with a suitable candidate having equivalent or better qualification.

#### **4. Arbitration**

The procedure for arbitration will be as follows:-

(a) In case of Dispute or difference arising between the Employer and a domestic contractor relating to any matter arising out of or connected with this agreement, such disputes or difference shall be settled in accordance with the Arbitration and Conciliation Act, 1996. The parties shall make efforts to agree on a sole arbitrator and only if such an attempt does not succeed, an Arbitral Tribunal consisting of 3 arbitrators one each to be appointed by the Employer and the Contractor and the Third Arbitrator to be chosen by the two Arbitrators so appointed by the Parties to act as Presiding Arbitrator, shall be considered. In case of failure of the two arbitrators appointed by the parties to reach upon a consensus within a period of 30 days from their appointment, the Presiding Arbitrator shall be appointed by Municipal Commissioner, Nagar Nigam Dehradun. A certified copy of the order of Municipal Commissioner, Nagar Nigam Dehradun, making such an appointment shall be furnished to each of the parties.



- (b) If one of the parties fails to appoint its arbitrator in pursuance of sub-clause (a) above within 30 days after receipt of the notice of the appointment of its arbitrator by the other party, Municipal Commissioner, Nagar Nigam Dehradun shall appoint the arbitrator. A certified copy of the order of the Municipal Commissioner, Nagar Nigam Dehradun, making such an appointment shall be furnished to each of the parties.
- (c) Arbitration proceeding shall be held at Dehradun, and the language of the arbitration proceeding and that of all documents and communications between the parties shall be English.
- (d) The decision of the majority of arbitrators shall be final and binding upon both parties. The cost and expenses of Arbitration proceedings will be paid as determined by the arbitral tribunal. However, the expenses incurred by each party in connection with the preparation, presentation, etc. of its proceeding as also the fees and expenses paid to the arbitrator appointed by such party or on its behalf shall be borne by each party itself.
- (e) Performance under the contract shall continue during the arbitration proceeding and payments due to the contractor by the employer shall not be withheld, unless they are the subject matter of the arbitration proceedings.

## **5. Protection of Environment:**

The contractor shall take all reasonable steps to protect the environment on and off the Site and to avoid damage or nuisance to persons or to property of the public or others resulting from pollution, noise or other causes arising as a consequence of his methods of operation.

During continuance of the contract, the contractor and his sub-contractors shall abide at all times by all existing enactments on environmental protection and rules made there under, regulations, notifications and bye-laws of the State or Central Government, or local authorities and any other law, bye-law, regulations that may be passed or notification that may be issued in this respect in future by the State or Central Government or the local authority.

Salient features of some of the major laws that are applicable are given below :

**The Water (Prevention and Control of Pollution) Act, 1974**, This provides for the prevention and control of water pollution and the maintaining and restoring of wholesomeness of water. 'Pollution' means such contamination of water or such alteration of the physical, chemical or biological properties of water or such discharge of any sewage or trade effluent or of any other liquid, gaseous or solid substance into water (whether directly or indirectly) as may, or is likely to, create a nuisance or render such water harmful or injurious to public health or safety, or to domestic, commercial, industrial, agricultural or other legitimate uses, or to the life and health of animals or plants or of aquatic organisms.

**The Air (Prevention and Control of Pollution) Act, 1981**, This provides for prevention, control and abatement of air pollution. 'Air Pollution' means the presence in the atmosphere of any 'air pollutant', which means any solid, liquid or gaseous substance (including noise) present in the atmosphere in such concentration as may be or tend to be injurious to human beings or other living creatures or plants or property or environment.

**The Environment (Protection) Act, 1986**, This provides for the protection and improvement of environment and for matters connected therewith, and the prevention of hazards to human beings, other living creatures, plants and property. 'Environment' includes water, air and land and the inter-relationship which exists among and between water, air and land, and human beings, other living creatures, plants, micro-organism and property.

**The Public Liability Insurance Act, 1991**, This provides for public liability insurance for the purpose of providing immediate relief to the persons affected by accident occurring while handling hazardous substances and for matters connected herewith or incidental thereto. Hazardous substance means any substance or preparation which is defined as hazardous substance under the Environment (Protection) Act 1986, and exceeding such quantity as may be specified by notification by the Central Government (This Act should cover his staff as well as Nagar Nigam Dehradun staff deployed at site work and the premium of which should be borne by the contractor).

## **SECTION – 4**

### **CONTRACT DATA**

## CONTRACT DATA

### Clause Reference with respect to section -3

Item marked "N/A" do not apply in this Contract.

1.	The Employer is: i) Name:- <b>Mr. Manuj Goyal (Municipal Commissioner)</b> ii) Address:-. <b>Nagar Nigam Dehradun</b>  Name of authorized Representative of the Employer- i) Name: <b>Mr. J. P. Raturi</b> ii) Address: <b>Executive Engineer, Nagar Nigam Dehradun</b> iii) Name of authorized Representative: <b>Mr. R. S. Panwar</b>	[Cl. 11]
2.	The Dispute Review Expert i) Name: <b>Mr. J. P. Raturi (Executive Engineer)</b>	[Cl. 1.1]
4	In the building and allied work Defect Liability Period is <b>365 days from the date of completion.</b>	[Cl.1.1 & 41.1]
5	The Start Date shall be <b>10 days for the date of issue of the Notice to proceed with the work/ issue of Work Order.</b>	[Cl.1.1]
6	The intended completion date for the whole of the work is <b>09 Months</b> after start of work. Work programme of which shall be submitted by the contractor and got approved from Engineer before start of the work.	[Cl.1.1,17.1]
7	The site is located at <b>Dehradun.</b>	[Cl.1.1]
8	The name and identification number of the Contract is ..... .....	[Cl.2.3h]
9	The work consists of as mentioned in the <b>Bill of Quantities.</b> (Section- 6).	[Cl.1.1]
10	Deleted	
11	The following documents may also form part of the Contract: <b>N/A</b>	[Cl.2.3]
12	The law, which applies to the contract, is <b>law of Union of India.</b>	[Cl.3.1]
13	The language of the contract documents is <b>English</b>	[Cl.3.1]
14	Sub-contractor of specialized works only such as electrical & fire fighting works etc.	[Cl.7.1]
15	The schedule of Other Contractor: <b>N/A</b>	[Cl.8.1]
16	The schedule of Key Personnel as per Annexure-II to Section-1.	[Cl.9.1]
17	(a) Loss of or damages to the Works, Plant and Material- Equal to the contract amount. (b) Loss of or damages to Equipments- 10% of contract amount (c) Loss of or damages of property (except the works, plant, materials and equipment) in connection with the contract-5% of contract amount and (d) Personal injury or death For other people – In accordance with the statutory requirements applicable to India. For contract people – In accordance with the statutory requirements applicable to India.	[Cl.13.1 (a)] [Cl.13.1 (b)] [Cl.13.1 (c)] [Cl.13.1 (d)]
18	Site investigation report- <b>N/A</b>	[Cl.14.1]
19	The Site Possession Date shall be: <b>10 days for the date of issue of the Notice to proceed with the work/ issue of Work Order.</b>	[Cl.21.1]
20	Fees and types of reimbursable expenses to be paid to the Dispute Review Expert: <b>5000.00 per meeting</b>	[Cl.25.1(h)]
21.	Appointing Authority for the Dispute Review Expert is <b>Mr. J. P. Raturi, (E.E. Nagar Nigam Dehradun).</b>	[Cl.24.1]

22.	The period for submission of the work program for approval of Engineer shall be 21 days from the issue of letter of Acceptance.	[Cl. 32.1]
23.	The Period between program updates shall be <b>7 days</b> .	[Cl.32.3]
24.	The amount to be withheld for late submission of an updated program shall be <b>Rs 50,000.00 from each bill</b> .	[Cl.32.3]
25.	The currency of the contract is <b>Indian National Rupees (INR)</b>	[Cl.50.1]
26.	The proportion of payments retained (retention money) shall be <b>5% from each bill subject to a maximum of 5% of final contract price</b> .	[Cl.52.1]
27.	Amount of liquidated damaged for delay in completion of works <b>0.5%</b> of the initial contract price, rounded off to the nearest thousand, per week.	[Cl.53.1]
28.	Maximum limit of liquidated damages for delay in completion of work. <b>10%</b> of the Initial Contract Price rounded off to the nearest thousand. The date of start of work may be maximum 10 days after the date of registration of contract. Mile stone (s) shall be as per table given below:-	[Cl. 53.1]

S.Nos.	Financial Progress	Time allowed (from date of start)	Grace period
1	1/8th/ (12.5%) of the cost of total work done.	1/4th (25%) of bonded period.	1/8th of the bonded time.
2	3/4th/(75%) of the cost of total work done.	3/4th (75%) of bonded period	-
3	Full/(100%) of the cost of total work done.	Full/(100%) of bonded period.	-
29.	Maximum limit of bonus for early completion of work: <b>N/A</b>		
30.	The amount of the advance payment are:		[Cl.54.1]

Nature of Advance	Amount (Rs.)	Conditions to Be fulfilled
i) Mobilization advance	10% of the Contract price	On submission of un-conditional Bank Guarantee. (to be drawn before the end of 20% of Contract period). The contractor shall furnish bank guarantee of equivalent amount of the advance, valid for full period.
ii) Equipment advance	90% for new and 50% of depreciated value for old equipment. Total amount will be subject to a maximum of 5% of the Contract price.	After equipment is brought to site (provided the Engineer is satisfied that the equipment is required for performance of the contract) and on submission of unconditional Bank Guarantee for amount of advance.
iii) Secured advances for non-	75% of Invoice Value	a) The materials are in accordance with the specification for works. b) Such materials have been delivered to site,

perishable materials brought to site		and are properly stored and protected against damage or deterioration to the satisfaction of the Engineer. The contractor shall store the bulk material in measurable stacks. c) The contractor's records of the requirements; order receipt and use of materials are kept in a form approved by the Engineer. d) The contractor has submitted with his statement the estimated value of the materials on site together with such documents as may be required by the Engineer for the purpose of valuation of the materials and providing evidence of ownership and payment thereof. e) Ownership of such materials shall be deemed to vest in the Employer for which the contractor has submitted and Indenture Bond in an acceptable format and f) The quantities of materials are not excessive and shall be used within three months/reasonable time as determined by the Engineer.
iv) Advance for accelerating progress of work.	10% of remaining quantum of work.	On submission of un-conditional Bank Guarantee of an amount equivalent to remaining quantum of work.

31.	Repayment of secured advance: Advance shall be repaid from each succeeding monthly payments to extent materials (for which advance was previously paid pursuant to Clause 57.4 of G.C.C.) have been incorporated into the works.	[Cl.54.4]
32.	The securities shall be for the following minimum amount equivalent as a percentage of the Contract Price. Performance Security/Performance Guarantee for 5% of contract value plus Rs..... (To be decided after evaluation of the bid) as additional security in terms of ITB Clause 29.5) The standard form of Performance Security acceptable to the employer shall be an <u>unconditional</u> Bank Guarantee of the types is presented in Section-7 of the Bidding Documents.	[Cl.55.1]
33.	The Schedule of Operation and Maintenance Manuals: <b>N/A</b>	[Cl. 63.1]
34.	The date by which 'as built' drawing (in scale as directed) in 2 sets are required is within 28 days of issue of certificate of completion of whole or section of the work, as the case may be.	[Cl. 63.1]
35.	The amount to be withheld for failing to supply 'as built' drawing by the date required is Rs. 1.00 Lac.	[Cl. 63.2]
36.	The following events shall also be fundamental breach of contract. "The contractor has contravened Sub-clause 7.1 and Clause-9 of GCC".	[Cl. 64.2]
37.	The percentage to apply to the value of the work not completed representing the Employer's additional cost for completing the works shall be 20 percent.	[Cl. 65.1]

**SECTION – 5**

**Technical  
Specification  
(Civil)**

**TECHNICAL SPECIFICATION**  
**(CIVIL)**

- 1- All work shall be carried out as per detailed CPWD specifications.
- 2- **Action where no specification is given**  
In the case of any class of work for which there is no specification in the Contract, such work shall be carried out in accordance with the detailed PWD specifications & in the event of there being no detailed specifications for the same, work shall be carried out in all respects in accordance with the instructions of the Engineer-in-Charge / manufacturers specification and good engineering practices.
- 4- The makes for the Civil, & Plumbing items are as follows: -

**(a) Civil:-**

S. No.	Item	Manufacturer's Name
1	Grey Cement (PPC)/(OPC-43 grade)	ACC, Ultratech, Ambuja, JK Cement, Shree Cement, Birla Gold, CCI, as approved by engineer in charge
2	White Cement	J.K, Birla or equivalent
3	Reinforcement Steel (TMT Bars Fe 415)	TMT bars of Tata, SAIL, RINL, Shyam Steel Industries as approved by Engineer-in-charge
4	Structural Steel sections	Conforming to IS- 800
5	Concrete Additives	Fosroc, Cico-tl, Sika
6	Anti termite	Chemical Pest Control India Ltd., Pest Con India, Pest Control Incorporated.
7	Tile grouts, Joint Filler	Laticrete, "Roff Rainbow Tile Mate" of Roff, Construction Chemicals Pvt. Ltd., Winsil20, Silicon Sealant of GE Bayer Silicon, Matrix Group. DU BOND
8	Polysulphide Sealant	Pidilite, Fosroc, STP.
9	Silicone Sealant	GE Bayer Silicone, Dow Corning, Wacker.
10	Epoxy over flooring	Fosroc, Sika or equivalent
11	Water Proofing Membrane – Bitumen Based	Sika, fosroc, Stp
12	Non Shrink grouts	Fosroc, cico, Sika
13	Non Metallic Floor Hardeners	Fosroc, sika, cico, Stp.
14	Bitumen	Shalimar tar products, Mathura oil refinery
15	Synthetic Enamel Paints	Berger (Luxol Gold), Nerolac (Full Gloss Hard Drying), Asian (Apolite), ICI Dulux (Gloss)
16	Oil Bound Distemper	Asian (Tractor), Berger (Durocem Extra), Nerolac (super Acrylic)
17	Cement Paint	Snowcem Plus, Berger (Durocem Extra), Nerolac (Nerolac with Titanium)
18	Plastic Emulsion Paint	ICI, Nerolac, Asian
19	Other Paints & Primer	ICI Dulux, Asian, Berger, Nerolac
20	Textured Coating	Spectrum, Heritage, Unitle
21	Melamine	ICI Dulux, Timberstone Melamine Coating
22	Silicon Water Repellent Solution	GE Bayer Silicon (I) Pvt. Ltd., Metroark P Ltd., or "Silicon Waterpeller" by STP Ltd., "Nisiwa-SH" of Mc- Baucheme (I) P Ltd.,



		“Techrepel” of Choksy chemicals P Ltd.
23	Ceramic Tiles (Glazed , Matt, Others)	Kajaria, Johnson, Somany.
24	Vitrified Porcelain Tiles	Kajaria, Somany Johnson
25	Adhesive for wood work	Dunlop, Fevicol, Vamicol, Pedilite
26	Wax Polish	Mansion, Reckitt & Colman
27	Stainless Steel Hinges	Canon, Union, haflon
28	Mirror & Float Glass	Modi Float Glass, Asahi Glass, Saint Gobain
29	Door Hardware , Closer	Godrej, Dorset, Dorma, Hettich.
30	Locks and Handles	Godrej, Dorset, Dorma, Hettich.
31	Aluminum Building Expansion Joints	Vexcolt, Watson Bowman, Acme, Z- Tech India, JMetco.
32	Water Stopper	Fixopan, Caliplast or equivalent
33	Asphalt Emulsion	STP, Karnak Chemical Corporation.
34	Expansion Fastener	Fischer, Hilti, Anchor
35	Stainless Steel	Salem, Jindal, Cavelier
36	Anchor Fastener , Anchor Bolts	Hilti, Fisher or equivalent
37	Corner Guards	Arpitha or equivalent
38	Electrodes	Advani-Overlikon, ESAB, Dwekam
39	Mineral Fibre Ceiling System	Armstrong, AMF, USG, DAIKIN
40	H.T. Bolts	Unbrako or equivalent
41	Fire Door ( Wooden )	Navair, Aadhunic , Radient
42	Aluminum Sections	Jindal, Hindalco, Indal
43	Rolling Shutter	Shivam, Milestones, Rama, Prakash
44	Glass wool and related products, Mineral wool	UP-Twiga, Owens Corning, Lloyds
45	Polycarbonate sheets	GE Plastics, Polygal, Sunlite
46	Self drilling Screws	Hilti, Builtex or equivalent
47	Logo, Signs, Name plates	D-Line, Sign Sutra or Equivalent.
48	Flush Doors	Archidply, Duro, Century, Alpro
49	MS Sliding Motorized Door	Shivam Associates – Beninca RI524 K System or equivalent
50	Water proofing compound	Pidilite, Cico, Fosroc
51	Flush Door	century, duro
52	Fasteners	Gun, Atul or equivalent
53	Aluminum fittings	Jindal, hindalco
54	POP	Sriram or equivalent
55	Glass	Modifloat/Saint Gobin/Asahi India Glassworkds Ltd.
56	UPVC Pipes and Fitting	Finolex/Supreme

<b>(b) PLUMBING SYSTEM</b>		
1	Vitreous China Sanitaryware	Parryware/Cera/Hindware
2	Plastic w.c.seats & covers	Parryware/Cera/Hindware
3	C.P. fittings: bib cock (long body/short body), pillar cock, single hole basin mixture, wall mixer, shower mixer, angle valve, concealed stop cock, shower with wall flange, c.p. waste 32-40 mm	Parko / Ceramix /Ess Ess

	dia,bottle trap, health faucet with steel beded connecting pipe.	
4	Automatic water taps, automatic urinal flushing system	Parko / Ceramix /Ess Ess
5	Towel ring, towel rod, towel rack, coat hook etc. (304 grade s.s.)	Parko / Ceramix /Ess Ess
6	Chromium plated / Stainless steel / poly Vinyl chloride grating	Cummun, Neer, Chilly
7	Stainless steel sink	Jaina /Neelkant
8	Sand cast iron spun pipe, centrifugally casted S & S as per is: 3989	Neco / Raj Iron foundry /RIF/SKF
9	Cast iron pipe, Horizontally / Vertically casted s & s as per is:1729	Neco / Raj Iron Foundry/ RIF/SKF
10	G.I. & M.S. pipes part-I is: 1239 upto 150 mm and M.S. pipes part-II is: 3589 above 150 mm	Tata steel (tube division)/ Jindal pipes limited
11	G.I. and M.S. fittings	Unique./ Zoloto / Kent
12	UPVC pipes & Fittings 4 kg./sqm, 6 kg./sqm, 10 kg./sqm Pressure.	Supreme industries limited/ Finolex industries/ Prince pipes & Fittings Private limited
13	CPVC pipes sdr12.5 schedule-40	Astral polytechnic private limited/ Ashirvad enterprises Private limited/ Jain plastics & Chemicals limited
14	HDPE pipe	Jain plastics & Chemicals limited/ Chemi plast industries sturoy polymers limited/ Kisan group of companies
15	C.I. class la pipes	Kesorma spun pipe & foundries, Calcutta/ Super enterprises/ Indian iron & co. ltd. Calcutta.
16	R.C.C. pipes	Pragati concrete Udyog/ K.K. spun pipes/ J.K. spun pipes/Sood & Sood
17	Stoneware pipes &Gully Trap	Devraj Anand ceramic (p) limited./ Perfect Pottery, Jabalpur (mp)/ Burn potteries, Jabalpur
18	Gunmetal valves (Full way, Check, Globe and non return valves)	Leader valves limited/ Arkay sales Corporation Delhi
19	Ball Valve	TBS Engineers Pvt. Ltd./ Virgo Engineering ltd./ Goojarmal Ganpatrai/ Audco India limited
20	Butterfly Valve (lever type)	Leader valves limited/ Castle Valves limited/ Audco India limited
21	Butterfly Valve (Gear Type)	Leader Valves limited/ Castle valves limited/ Audco India limited/ Guojarmal Ganpatrai
22	C.I. Double Flanged Sluice Valve & Gate Valves	Kirloskar brothers limited/ Aarko manufacturing company/ Arrow Engg.ltd
23	Float valve (Gunmetal) upto 40m	Sant Industrial controls (p) limited/ Bombay metal & alloys/ Leader valves limited
24	Float Valve (CI) 50m and above	Leader valves limited/ Indian valve co ltd.
25	Foot valve / Check valves (brass)	Leader valves limited/ Indian valve co. ltd. Calcutta/ Advance valves(p) limited/ Goojarmal Ganpatrai,/ Aarko manufacturing company

26	Air release valves (Brass/ Cast Iron)	Leader valves limited/ Advance valves (p) limited/ Aarko manufacturing company/ Goojarmal Ganpatrai
27	C.I. Manholes cover & G.I. grating	K.K. Manhole & Grating co. private limited/ Bangal iron company West Bangal/ Shining Engineering works (foundry) Agra.
28	Hand Drier (304 grade S.S.)	The Veera Trading company/ Kopal Engg. Corpn.New Delhi/ Askon Engineers Bombay
29	Electrical hot water heater	Venus/ Kingston
30	PVC Foot rest & SFRC	Covers K.K. Manholes or Equivalent
31	water tank	Sintex, Ganga Gold, Himgiri triple layer,
34	IWC/EWC/Wash Basins	Hindware/Parry Ware/Cera
35	GI Specials	Jindal/TATA

### **WATER SUPPLY**

1.	GI Pipes	1239 Pt I 1979	JINDAL, TATA, ADVANCE STEEL TUBES, ZENITH, BST
2.	HDPE pipes	4984-1985	RELIANCE (RELPIPE/HASTI), RISHI, PRIME, KAVERI, VECTUS
3.	CI / DI Pipe	1536-1976	ELECTRO STEEL, KESORAM, TISCO, JINDAL
4.	ERW Pipes	11722-	JINDAL, BST, TATA, TIRUPATI
5.	Sluice Valve/Gate valve/ Foot Valve	780-1969 2906-1969	KIRLOSKAR, LEADER, L&T
6.	Non-Return Valve	5312- 1979	KIRLOSKAR, LEADER, L&T
7.	Pump Sets/Mono Block	-	KIRLOSKAR, CROMPTON, JYOTI, BEACON, MAXFLOW
8.	Centrifgal Pumps	1710-1973	KIRLOSKAR, CROMPTON, BECON, KSB
9.	Submersible Pump	1520-1972	KSB, CROMPTON GREAVES, KIRLOSKAR, GRUNDFOS

## **SPECIFICATION – I (Civil work)**

### **SUB HEAD: 0.0**

#### **GENERAL**

**Note:-** All Work shall be carried out as per latest NCHM/AICTE and CPWD specification Volume -1 &-2 and corrigendum issued from time to time by appropriate authority. Contractor to abide to follow the specification as mentioned. However brief specification for building work, sanitary work and electrical enclosed for ready reference and implement on ground while executing the work.

**0.1** Reference mentioned herein shall be applicable to all sections to the extent the context permits and are intended to supplement the provisions in the particular section. In case of any discrepancy/deviation, the provisions in the particular section shall take precedence.

**0.2** The rates for all items of work unless clearly specified otherwise shall include cost of all labour, materials and other inputs involved in the execution of the items.

#### **0.3 INTERPRETATIONS**

**0.3.1** The Director General (Works), CPWD shall be the sole deciding authority as to the meaning, interpretation and implications for various provisions of the specifications. His decision in writing shall be final.

**0.3.2** Wherever any reference is made to any Indian Standard, it shall be taken as reference to the latest edition with all amendments issued thereto. In the event of any variation between the CPWD specifications and the Indian Standard, the former shall take precedence over the latter.

**0.3.3** To Insure the construction of building according to design and provide arrangement for office installation based on sustainable design principles and also insure OHS, NIC & LEED norms.

#### **0.4 DEFINITIONS**

The following terms and expressions in the specifications shall have the meaning or implication hereby assigned to them unless otherwise specified elsewhere.

**0.4.1** Contractor: The Contractor shall mean the individual or firm or company whether incorporated or not undertaking the works and shall include the legal personal representatives of such individual or the persons composing such firm or company, or the successors of such individual or firm or company and the permitted assignees of such individual or firm of company.

**0.4.2** *Engineer-in-Charge:* The 'Engineer-in-Charge' means the Engineer officer who shall supervise and be in-charge of the work and who shall sign the contract on behalf of the President.

**0.4.3** *Site:* The 'site' shall mean the land/ or other places on, in, into or through which the work is to be executed under the contract or any adjacent land, path or street through which the work is to be executed under the contract, or any adjacent land, path or street which may be allotted or used for the purpose of carrying out the contract.

**0.4.4** *Store:* The 'store' shall mean the place of issue of materials included in the appropriate schedule of a contract for issue by the CPWD. In all other cases 'Store' shall mean any CPWD store in the district.

**0.4.5** *IS:* The standards, specification and code of practices issued by the Bureau of Indian Standards.

**0.4.6** *Best*: The word ‘best’ when used shall mean that in the opinion of the Engineer-in-Charge, there is no superior material/ article and workmanship obtainable in the market and trade respectively. As far as possible the standard required shall be specified in preference to the word ‘best’.

**0.4.7** *Department*: ‘Department’ shall mean Central Public Works Department (CPWD).

## **0.5 FLOOR AND LEVELS**

### **0.5.1 Building**

**0.5.1.1** Floor 1 is the lowest floor above the ground level in the building unless otherwise specified in a particular case. The floors above floor 1 shall be numbered in sequence as floor 2, floor 3 and so on. The number shall increase upwards.

**0.5.1.2** Floor level: For floor 1, top level of finished floor shall be the floor level and for all other floors above floor 1, top level of the structural slabs shall be the floor level.

**0.5.1.3** Plinth level: Floor 1 level or 1.2 m above the ground level whichever is lower shall be the plinth level.

### **0.5.2 Special Structures**

**0.5.2.1** For structures like retaining walls, wing walls, chimneys, over head reservoirs/ tanks and other elevated structures, where elevations/ heights above a defined datum level have not been specified and identification of floors cannot be done as in case of building. Level, at 1.2 m above the ground level shall be the floor 1 level as well as plinth level. Level at a height of 3.5 m above floor 1 level will be reckoned as floor 2 level and level at a height of 3.5 m above the floor 2 level will be floor 3 level and so on, where the total height above floor 1 level is not a whole number multiple of 3.5 metre. Top most floor level shall be the next in sequence to the floor level below even if the difference in height between the two upper most floor levels is less than 3.5 metres

## **0.6 FOUNDATION AND PLINTH**

The work in foundation and plinth shall include:

- (a) For buildings: All works upto 1.2 metre above ground level or upto floor 1 level whichever is lower:
- (b) For abutments, piers and well steining: all works upto 1.2 m above the bed level:
- (c) For retaining wall, wing walls, compound walls, chimneys, over head reservoirs/ tanks and other elevated structures: All works upto 1.2 metre above the ground level:
- (d) For reservoirs/ tanks (other than overhead reservoirs/ tanks): All works upto 1.2 metre above the ground level:
- (e) For basements: All works upto 1.2 m above ground level or upto floor 1 level whichever is lower.

**Note:** Specific provision shall be made in the estimate for such situations where the foundation level is more than 3 (three) metre depth from the plinth for all types of structures mentioned above.

## **0.7 MEASUREMENTS**

**0.7.1** In booking dimensions, the order shall be consistent and in the sequence of length, width and height or depth or thickness.

**0.7.2** Rounding off: Rounding off where required shall be done in accordance with IS: 2-1960. The number of significant places rounded in the rounded off value should be as specified.

## **0.8 MATERIALS**

**0.8.1** Samples of all materials to be used on the work shall be got approved by the contractor from the Engineer-in-Charge well in time. The approved samples duly authenticated and sealed shall be kept in the custody of the Engineer-in-Charge till the completion of the work. All materials to be provided by the

contractor shall be brand new and as per the samples approved by the Engineer-in-Charge.

- 0.8.2** Materials obtained by the contractor from the sources approved by the Department shall be subjected to the Mandatory tests. Where such materials do not conform to the relevant specifications, the matter shall be taken up by the Engineer-in-Charge for appropriate action against the defaulters. In all such cases, necessary documents in original and proof of payment relating to the procurement of materials shall be made available by the contractor to the Engineer-in-Charge.
- 0.8.3** Samples, whether submitted for approval to govern bulk supplies or required for testing before use and also the sample of materials bearing 'Standard mark,' if required for testing, shall be provided free of cost by the contractor. All other incidental expenditure to be incurred for testing of samples e.g. packaging, sealing transportation, loading, unloading etc. except testing charges shall be borne by the contractor.
- 0.8.4** The materials, supplied by the Department shall be deemed to be complying with the specifications.
- 0.8.5** Materials stored at site, depending upon the individual characteristics, shall be protected from atmospheric effects due to rain, sun, wind and moisture to avoid deterioration.
- 0.8.6** Materials like timber, paints etc. shall be stored in such a way that there may not be any possibility of fire hazards. Inflammable materials and explosives shall be stored in accordance with the relevant rules and regulations or as approved by Engineer-in-Charge in writing so as to ensure desired safety during storage.
- 0.8.7** The unit weight of materials unless otherwise specified shall be reckoned as given in IS: 1911- 1967.

## **0.9 SAFETY IN CONSTRUCTION**

- 0.9.1** The contractor shall employ only such methods of construction, tools and plant as are appropriate for the type of work or as approved by Engineer-in-Charge in writing.
- 0.9.2** The contractor shall take all precautions and measures to ensure safety of works and workman and shall be fully responsible for the same. Safety pertaining to construction works such as excavation, centering and shuttering, trenching, blasting, demolition, electric connections, scaffolds, ladders, working platforms, gangway, mixing of bituminous materials, electric and gas welding, use of hoisting and construction machinery shall be governed by CPWD safety code, relevant safety codes and the direction of Engineer-in-Charge

## **0.10 ABBREVIATIONS**

The following abbreviations wherever they appear in the specifications, shall have the meaning or implication hereby assigned to them:

Mm	Millimetre
Cm	Centimetre
M	Metre
Km	Kilometre
Mm <sup>2</sup> /sqmm	Square Milimetre
Cm <sup>2</sup> /sqcm	Square centimetre
Dm <sup>2</sup> /sqdm	Square decimetre
M <sup>2</sup> /sqm	Square metre
Cm <sup>3</sup> / cubic cm	Cubic centimetre
Dm <sup>3</sup> / cubic dm	Cubic decimetre
M <sup>3</sup> /cum	Cubic metre
MI	Millilitre

Kl	Kilolitre
Gm	Gram
Kg	Kilogram
Q	Quintal
T	Tonne
Fps system	Foot pound second system
°C	Degree Celsius temperature
Fig	Figure
Re/Rs	Rupee/ Rupees
No	Number
Dia	Diameter
AC	Asbestos cement
CI	Cast Iron
GC	Galvanised corrugated
GP	Galvanised plain
GI	Galvanised iron
PVC	Polyvenyl chloride
RCC	Reinforced cement concrete
SW	Stone ware
SWG	Standard wire Gauge

#### **0.11 Application of specification and item of work:**

This specification forms part of the contract and shall be read in conjunction with other documents forming the contract, viz. Notice inviting BID, conditions and requirements of tendering, Scope of work and technical information, General terms and conditions of contract, General and Technical Specification, drawings, Bill of quantities and schedule of probable items of works.

The offered rates must cover the cost of all materials, all taxes & duties in vogue, labour, tools, machinery, plant, explosives, scaffolding, staging, shoring, props, bamboos, ropes templates, pegs, and all appliances and operations whatever necessary for efficient execution and completion of the work.

All works are to be executed in accordance with descriptions in the schedule of item of works along with the specifications, terms, conditions provided elsewhere in the tender documents.

Item of works and their details, which are not covered by this specification, shall be carried out as per those of P.W.D department, Govt. of Uttarakhand/CPWD, and relevant IS recommendation.

Manner of works not included above, should be carried out as per relevant provisions of CPWD/PWD Uttarakhand Manual relevant I.S. specifications and code of practice and as per manufacturer's specification (where ever necessary), as per direction of Engineer-In-charge.

The overall outline of works to be done by the contractor and the detail have been mentioned in the item of works in the schedule and in the specification, drawing and elsewhere in the tender documents. Each scheduled item has to be carried out and completed by the contractor at the accepted rate covering the full extent outlined in the schedule and specification and not withstanding any omission in mentioning of supply and execution of such component of works except in special case specifically mentioned. Items indicated in the schedule are exhaustive. Yet if there by any short

fall felt by the tenderer he may include the same while quoting his rate so as to make the item complete in all respect for successful completion of the work.

The contractor's works shall be guided by the total requirement briefly outlined and shall include additional works other than those component of works mentioned in the item to complete the work. The tenderer or the contractor has to completely execute the full requirements ensuring performance guarantee of each component of the works, equipment and machinery so that all the individual components are brought up to the optimum condition for sustained and satisfactory operation individually and collectively.

**0.12 Site Condition:**

The contractor is to visit the site and ascertain local conditions, traffic restrictions, and obstructions in the area before submission of tender paper to satisfy himself.

**0.13 Setting out and leveling:**

The contractor is to set out and level all the works in accordance with the approved drawings, and will be responsible for the accuracy of the same. They have to provide all instruments, setting out equipments and proper qualified staff required for the setting works. If any error will be found during checking by the department, re-setting out will have to be carried out by the contractor with out any extra payment. If any works found faulty due to erroneous setting outworks, the contractor shall have to rectify the same with out any extra cost.

**0.14 Safety Code:**

The contractor shall take adequate precaution to provide complete safety for prevention of accidents on the site.

**0.15 Arrangement of Water & Electricity:**

The contractor shall provide and maintain at his own cost, the drinking water for the labours and staff, construction water for the project, electricity for the construction of work (If required) and Chowkidar (Guard) for protection of material and site, till the site is handed over to the complete satisfaction of Engineer-in-Charge.

**0.16 Clear Site:**

The site during the execution of works should have sober and tidy appearance with everything necessary for the work neatly and systematically arranged.

After the completion of the work, the entire site shall be cleared satisfactorily with (a) all pits, diggings and trenches properly filled up (b) all surfaces adequately dressed (c) all surplus materials, sheds, tents and all other ancillaries removed from the site at his own cost.

**0.17 Bench Marks and Ground Water Gauges:**

The contractor shall establish and protect surveyor's benchmarks and base line marks from damage or movement during work at his cost.

**0.18 Inspection:**

The contractor shall inspect the site of work and ascertain site conditions and the nature of soil to be excavated and other work to be executed for completion of the project.



**0.19 Contractor's Staff:**

The contractor must provide at all times efficient staff of trustworthy, skilful and experienced assistants capable of carrying out the work in accordance with the drawings and specifications and to correct levels in accordance with the provisions made in the relevant clause of the PQ Bid document and contract agreements and also as per good Engineering practices.

**0.20 Measurement of Work:**

The CONTRACTOR or his authorized site engineer shall be available at site at all reasonable times to take joint measurement of work done for the purpose of payment and shall also provide without any extra charges, the necessary measuring instruments and men.

**0.21 APPROVAL OF MATERIALS**

Sample of materials in sufficiently large quantity with descriptive data thereof shall be furnished by the contractor to the Engineer-in-charge well before the collection of such materials and equipments so as to permit inspection, testing and approval. The sample shall be properly marked to show the name of the materials, name of manufacturer, place of origin and item for which it is to be used. After approval, the sample shall be available for inspection at all time.

All materials to be supplied by the contractor shall conform to the requisite I.S. specification properly tested and duly certified. Those are to be approved by the Engineer-in-charge before use.

## **SUB HEAD: 1.0 CARRIAGE OF MATERIALS**

### **1.0 GENERAL**

The carriage and stacking of materials shall be done as directed by the Engineer-in-Charge. Any tools and plants, required for the work shall be arranged by the Contractor. The carriage of materials includes loading within a lead of 50 metres, unloading and stacking within a lead of 50 metres.

### **GENERAL CONSIDERATION FOR STACKING AND STORAGE**

#### **1. Planning of Storage Layout**

For any site, there should be proper planning of the layout for stacking and storage of different materials, components and equipments with proper access and proper manoeuvrability of the vehicles carrying the material.

### **STACKING AND STORAGE OF MATERIALS**

#### **Cement**

**In case cement is received in bags.** Cement shall be stored at the work site in a building or a shed which is dry, leakproof and as moisture proof as possible. The building or shed for storage should have minimum number of windows and close fitting doors and these should be kept closed as far as possible. Cement shall be stored and stacked in bags and shall be kept free from the possibility of any dampness or moisture coming in contact with them. Cement bags shall be stacked off the floor on wooden planks in such a way as to keep about 150 mm to 200 mm clear above the floor. The floor may comprise of lean cement concrete or two layers of dry bricks laid on well consolidated earth. A space of 600 mm minimum shall be left all around between the exterior walls and the stacks. In the stacks the cement bags shall be kept close together to reduce circulation of air as much as possible. Owing to pressure on the bottom layer of bags sometimes 'warehouse pack' is developed in these bags. This can be removed easily by rolling the bags when the cement is taken out for use. lumbed bags, if any should be removed and disposed off.

#### **1.8 BRICKS**

Bricks shall be stacked in regular tiers as and when they are unloaded to minimize breakage and defacement. These shall not be dumped at site. Bricks stacks shall be placed close to the site of work so that least effort is required to unload and transport the bricks again by loading on pallets or in barrows. Building bricks shall be loaded or unloaded a pair at a time unless palletized. Unloading of building bricks or handling in any other way likely to damage the corners or edges or other parts of bricks shall not be permitted.

**1.8.4** Bricks of different types, such as clay bricks, clay fly ash bricks, fly ash lime bricks, sand lime (calcium silicate) bricks, auto-clave bricks etc. shall be stacked separately. Bricks of different classification and size consideration (such as, conventional and modular) shall be stacked separately. Also bricks of different types, such as, solid, hollow and perforated shall be stacked separately.

#### **1.9 BLOCKS**

**1.9.1** Blocks are available as hollow and solid concrete blocks, hollow and solid light weight concrete blocks, autoclaved aerated concrete blocks, concrete stone masonry blocks and soil based blocks.

**1.9.2** Blocks shall be unloaded one at a time and stacked in regular tiers to minimize breakage and defacement. These shall not be dumped at site. The height of the stack shall not be more than 1.2 m. The length of the stack shall not be more than 3.0 m, as far as possible and the width shall be of two or three blocks.

**1.9.4** Blocks shall be placed close to the site of work so that least effort is required for their transportation.

## **1.10 FLOOR, WALL AND ROOF TILES**

**1.10.1** Floor, wall and clay roof tiles of different types, such as, cement concrete tiles (plain, coloured and terrazzo) and ceramic tiles (glazed and unglazed) shall be stacked on regular platform as far as possible under cover in proper layers and in tiers and they shall not be dumped in heaps. In the stack, the tiles shall be so placed that the mould surface of one faces that of another. Height of the stack shall not be more than one metre. During unloading, these shall be handled carefully so as to avoid breakage. Tiles of different quality, size and thickness shall be stacked separately to facilitate easy removal for use in work. Tiles when supplied by manufacturers packed in wooden crates, shall be stored in crates. The crates shall be opened one at a time as and when required for use. Ceramic tiles and clay roof tiles are generally supplied in cartons which shall be handled with.

## **1.11 AGGREGATES**

**1.11.1** Aggregates shall be stored at site on a hard dry and level patch of ground. If such a surface is not available, a platform of planks or old corrugated iron sheets, or a floor of bricks, or a thin layer of lean concrete shall be made so as to prevent contamination with clay, dust, vegetable and other foreign matter.

**1.11.2** Stacks of fine and coarse aggregates shall be kept in separate stock piles sufficiently removed from each other to prevent the material at the edges of the piles from getting intermixed. On a large job, it is desirable to construct dividing walls to give each type of aggregates its own compartment. Fine aggregates shall be stacked in a place where loss due to the effect of wind is minimum.

## **1.13 STEEL**

**1.13.1** For each classification of steel, separate areas shall be earmarked. It is desirable that ends of bars and sections of each class be painted in distinct separate colours.

**1.13.2** Steel reinforcement shall ordinarily be stored in such a way as to avoid distortion and to prevent deterioration and corrosion. It is desirable to coat reinforcement with cement wash before stacking to prevent scaling and rusting.

**1.13.3** Bars of different classification, sizes and lengths shall be stored separately to facilitate issues in such sizes and lengths so as to minimize wastage in cutting from standard lengths.

**1.13.4** In case of long storage, reinforcement bars shall be stacked above ground level by at least 150 mm. Also in coastal areas or in case of long storage a coat of cement wash shall be given to prevent scaling and rusting.

**1.13.5** Structural steel of different classification, sizes and lengths shall be stored separately. It shall be stored above ground level by at least 150 mm upon platforms, skids or anyother suitable supports to avoid distortion of sections. In coastal areas or

in case of long storage suitable protective coating of primer paint shall be given to prevent scaling and rusting.

**1.17 GYPSUM BOARDS, PLYWOOD, FIBREBOARD, PARTICLE BOARD, BLOCK BOARD, ETC.**

**1.17.1** These boards shall be stored flat in a covered clean and dry place. Different sizes and types of each of these boards shall be stacked separately. The board shall be stacked on a flat platform on which a wooden frame shall be constructed with 50 mm x 25 mm battens in such a way that it will give support to all four edges and corners of the boards with intermediate battens placed at suitable intervals to avoid warping. The boards shall be stacked in a solid block in a clear vertical alignment. The top sheet of each stack shall be suitably weighed down to prevent warping wherever necessary. The boards shall be unloaded and stacked with utmost care avoiding damage to the corners and surface. In case of decorative plywood and decorative boards, the surfaces of which are likely to get damaged by dragging one sheet over another it is advisable that these are lifted as far as possible in pairs facing each other.

**1.23 WATER**

**1.23.1** Wherever water is to be stored for construction purposes this shall be done in proper storage tanks to prevent any organic impurities getting mixed up with it.

**1.26 OTHER MATERIALS**

**1.26.1** Small articles like nails, screws, nuts and bolts, door and window fittings, polishing stones, protective clothing, spare parts of machinery, linings, packing, water supply and sanitary fittings, electrical fittings, insulation board, etc, shall be kept in suitable and properly protected store rooms. Valuable small material such as, copper pipes and fittings shall be kept under lock and key.

**For further detail refer CPWD specification volume 1, Clause 1.0**

## SUB HEAD : 2.0 EARTH WORK

### DEFINITIONS

**Deadmen or Tell Tales:** Mounds of earth left undisturbed in pits dug out for borrowing earth

**Burjis:** Short pillars of brick/ stone having top surface finished with cement plaster for marking etc.

**Formation or Profile:** Final shape of the ground after excavation or filling up.

**Foul condition:** Filthy and unhygienic conditions where physical movements are hampered such as soil mixed with sewage or night soil.

**Lead :** All distances shall be measured over the shortest practical route and not necessarily the route actually taken. Route other than shortest practical route may be considered in cases of unavoidable circumstances and approved by Engineer-in-charge along with reasons in writing. Carriage by manual labour shall be reckoned in units of 50 metres or part thereof. Carriage by animal and mechanical transport shall be reckoned in one km. unit. Distances of 0.5 km. or more shall be taken as 1 km. and distance of less than 0.5 km. shall be ignored. However, when the total lead is less than 0.5 km., it will not be ignored but paid for separately in successive stages of 50 metres subject to the condition that the rate worked on this basis does not exceed the rate for initial lead of 1 km. by mechanical/animal transport.

**Lift:** The vertical distance for removal with reference to the ground level. The excavation up to 1.5 metres depth below the ground level and depositing the excavated materials upto 1.5 metres above the ground level are included in the rate of earth work. Lifts inherent in the lead due to ground slope shall not be paid for.

**Safety rules:** Safety rules as laid down by the statutory authority and as provided in National Building Code (NBC) shall be followed.

### 2.1 CLASSIFICATION OF SOILS

**2.1.0** The earthwork shall be classified under the following categories and measured separately for each category:

- (a) **All kind of soils:** Generally any strata, such as sand, gravel, loam, clay, mud, black cotton moorum, shingle, river or nallah bed boulders, siding of roads, paths etc. and hard core, macadam surface of any description (water bound, grouted tarmac etc.), lime concrete mud concrete and their mixtures which for excavation yields to application of picks, showels, jumper, sacrifiers, ripper and other manual digging implements.
- (b) **Ordinary rock:** Generally any rock which can be excavated by splitting with crow bars or picks and does not require blasting, wedging or similar means for excavation such as lime stone, sand stone, hard laterite, hard conglomerate and un-reinforced cement concrete below ground level. If required light blasting may be resorted to for loosening the materials but this will not in any way entitle the material to be classified as 'Hard rock'.
- (c) **Hard rock:** Generally any rock or boulder for the excavation of which blasting is required such as quartzite, granite, basalt, reinforced cement concrete (reinforcement to be cut through but not separated from concrete) below ground level and the like.

### 2.2 ANTIQUITIES AND USEFUL MATERIALS

**2.2.1** Any finds of archaeological interest such as relics of antiquity, coins, fossils or other articles of value shall be delivered to the Engineer-in-Charge and shall be the property of the Government. **2.2.2** Any material obtained from the excavation which in the opinion of the Engineer-in-Charge is useful shall be stacked separately in

regular stacks as directed by the Engineer-in-Charge and shall be the property of the Government.

### **2.3 PROTECTIONS**

**2.3.1** Excavation where directed by the Engineer-in-Charge shall be securely barricaded and provided with proper caution signs, conspicuously displayed during the day and properly illuminated with red lights and/or written using fluorescent reflective paint as directed by engineer in charge during the night to avoid accident.

**2.3.2** The Contractor shall take adequate protective measures to see that the excavation operations do not damage the adjoining structures or dislocate the Service. Water supply pipes, sluice valve chambers, sewerage pipes, manholes, drainage pipes and chambers, communication cables, power supply cables etc. met within the course of excavation shall be properly supported and adequately protected, so that these Service remain functional. However, if any service is damaged during excavation shall be restored in reasonable time.

**2.3.3** Excavation shall not be carried out below the foundation level of the adjacent buildings until underpinning, shoring etc. is done as per the directions of the Engineer-in-Charge for which payment shall be made separately.

**2.3.4** Any damages done by the contractor to any existing work shall be made good by him at his own cost. Existing drains pipes, culverts, over head wires, water supply lines and similar Service encountered during the course of execution shall be protected against damage by the contractor. The contractor shall not store material or otherwise occupy any part of the site in manner likely to hinder the operations of such Service.

### **2.4 SITE CLEARANCE**

**2.4.1** Before the earth work is started, the area coming under cutting and filling shall be cleared of shrubs, rank vegetation, grass, brushwood, trees and saplings of girth up to 30cm measured at a height of one metre above ground level and rubbish removed up to a distance of 50 metres outside the periphery of the area under clearance. The roots of trees and saplings shall be removed to a depth of 60cm below ground level or 30 cm below formation level or 15 cm below sub grade level, whichever is lower, and the holes or hollows filled up with the earth, rammed and leveled.

**2.4.2** The trees of girth above 30 cm measured at a height of one metre above ground shall be cut only after permission of the Engineer-in-Charge is obtained in writing. The roots of trees shall also be removed as specified in 2.4.1. payment for cutting such trees and removing the roots shall be made separately.

**2.4.3** Existing structures and Service such as old buildings, culverts, fencing, water supply pipe lines, sewers, power cables, communication cables, drainage pipes etc. within or adjacent to the area if required to be diverted/removed, shall be diverted/dismantled as per directions of the Engineer-in-Charge and payment for such diversion/dismantling works shall be made separately.

**2.4.4** In case of archaeological monuments within or adjacent to the area, the contractor shall provide necessary fencing around such monuments as per the directions of the Engineer-in-Charge and protect the same properly during execution of works. Payment for providing fencing shall be made separately.

**2.4.5** Lead of 50 m mentioned in the 'Schedule Of Quantities' is the average lead for the disposal of excavated earth within the site of work. The actual lead for the lead for the disposal of earth may be more or less than the 50 m for which no cost adjustment shall be made in the rates.

**2.4.6** Disposal of Earth shall be disposed off at the specified location or as decided by the Engineer-in-Charge. The contractor has to take written permission about place of disposal of earth before the earth is disposed off, from Engineer-in-Charge.

## **2.5 SETTING OUT AND MAKING PROFILES**

**2.5.1** A masonry pillar to serve as a bench mark will be erected at a suitable point in the area, which is visible from the largest area. This bench mark shall be constructed as per Fig. 2.1 and connected with the standard bench mark as approved by the Engineer-in-Charge. Necessary profiles with strings stretched on pegs, bamboos or 'Burjis' shall be made to indicate the correct formation levels before the work is started. The contractor shall supply labour and material for constructing bench mark, setting out and making profiles and connecting bench mark with the standard bench mark at his own cost. The pegs, bamboos or 'Burjis' and the bench mark shall be maintained by the contractor at his own cost during the excavation to check the profiles.

**2.5.2** The ground levels shall be taken at 5 to 15 metres intervals (as directed by the Engineer-in-Charge) in uniformly sloping ground and at closer intervals where local mounds, pits or undulations are met with. The ground levels shall be recorded in field books and plotted on plans. The plans shall be drawn to a scale of 5 metres to one cm or any other suitable scale decided by the Engineer-in-Charge. North direction line and position of bench mark shall invariable be shown on the plans. These plans shall be signed by the contractor and the Engineer-in-Charge or their authorized representatives before the earth work is started. The labour required for taking levels shall be supplied by the contractor at his own cost.

## **2.6 EXCAVATION IN ALL KINDS OF SOILS**

**2.6.1** All excavation operations manually or by mechanical means shall include excavation and 'getting out' the excavated materials. In case of excavation for trenches, basements, water tanks etc. 'getting out' shall include throwing the excavated materials at a distance of at least one metre or half the depth of excavation, whichever is more, clear off the edge of excavation. In all other cases 'getting out' shall include depositing the excavated materials as specified. The subsequent disposal of the excavated material shall be either stated as a separate item or included with the items of excavation stating lead.

**2.6.2** During the excavation the natural drainage of the area shall be maintained. Excavation shall be done from top to bottom. Undermining or undercutting shall not be done.

**2.6.3** In firm soils, the sides of the trenches shall be kept vertical upto a depth of 2 metres from the bottom. For greater depths, the excavation profiles shall be widened by allowing steps of 50 cms on either side after every 2 metres from the bottom. Alternatively, the excavation can be done so as to give slope of 1:4 (1 horizontal : 4 vertical). Where the soil is soft, loose or slushy, the width of steps shall be suitably increased or sides sloped or the soil shored up as directed by the Engineer-in-Charge. It shall be the responsibility of the contractor to take complete instructions in writing from the Engineer-in-Charge regarding the stepping, sloping or shoring to be done for excavation deeper than 2 metres.

- 2.6.4** The excavation shall be done true to levels, slope, shape and pattern indicated by the Engineer-in-Charge. Only the excavation shown on the drawings with additional allowances for centering and shuttering or as required by the Engineer-in-Charge shall be measured and recorded for payment.
- 2.6.5** In case of excavation for foundation in trenches or over areas, the bed of excavation shall be to the correct level or slope and consolidated by watering and ramming. If the excavation for foundation is done to a depth greater than that shown in the drawings or as required by the Engineer-in-Charge, the excess depth shall be made good by the contractor at his own cost with the concrete of the mix used for levelling/ bed concrete for foundations. Soft/defective spots at the bed of the foundations shall be dug out and filled with concrete (to be paid separately) as directed by the Engineer-in-Charge.
- 2.6.6** While carrying out the excavation for drain work care shall be taken to cut the side and bottom to the required shape, slope and gradient. The surface shall then be properly dressed. If the excavation is done to a depth greater than that shown on the drawing or as required by the Engineer-in-Charge, the excess depth shall be made good by the contractor at his own cost with stiff clay puddle at places where the drains are required to be pitched and with ordinary earth, properly watered and rammed, where the drains are not required to be pitched. In case the drain is required is to be pitched, the back filling with clay puddle, if required, shall be done simultaneously as the pitching work proceeds. The brick pitched storm water drains should be avoided as far as possible in filled-up areas and loose soils.
- 2.6.7** In all other cases where the excavation is taken deeper by the contractor, it shall be brought to the required level by the contractor at his own cost by filling in with earth duly watered, consolidated and rammed.
- 2.6.8** In case the excavation is done wider than that shown on the drawings or as required by the Engineer-in-Charge, additional filling wherever required on the account shall be done by the contractor at his own cost.
- 2.6.9** The excavation shall be done manually or by mechanical means as directed by Engineer-in-charge considering feasibility, urgency of work, availability of labour /mechanical equipments and other factors involved. Contractor shall ensure every safety measures for the workers. Neither any deduction will be made nor any extra payment will be made on this account.

## **2.7 EARTH WORK BY MECHANICAL MEANS**

Earth work by mechanical means involves careful planning keeping in view site conditions i.e. type of soil, nature of excavation, distances through which excavated soil is to be transported and working space available for employing these machines. The earth moving equipment should be accordingly selected. The earth moving equipment consists of excavating and transporting equipment. Excavating equipment may be further classified as excavators and tractor based equipment.

### **2.7.1 Excavators**

Excavators generally used at site are as follows:

- (i) **Dipper–shovel** : It is used for excavating against a face or bank consisting of open-top bucket or dipper with a bottom opening door, fixed to an arm or dipper stick which slides and pivots on the jib of the crane. It is suitable for excavating all clay chalk and friable materials and for handling rock and stone. However, it is not suitable for surface excavation for which a skimmer is used. (ii) **Backhoe** : It is similar to face shovel except that the dipper stick pivots on the end of the jib and the dipper or bucket works towards the chassis and normally has no bottom door but is emptied by swinging away from the chassis to invert the bucket. It may be designed



to carry both a front –mounted bucket loading mechanism and a rear mounted backhoe. It is mainly used to excavate trenches and occasionally used for the excavation of open areas such as small basements. In the backhoe mode the bucket lifts, swings and discharges materials while the undercarriage is stationary. When used in the ‘loader’ mode, the machine loads or excavated through forward motion of the machine, and lifts, transports and discharges materials.

- (iii) **Skimmer** : This arrangement is similar to the face shovel except that in this case the bucket slides on rollers directly along the jib and thus has a more restricted movement. It is used for surface excavation and levelling in conjunction with transport to haul away the excavated material.
- (iv) **Dragline** : It is usually fitted with a long slender boom or jib and the bucket, which in operation faces towards the machine and has no door, is supported by cable only as on a crane. It works from the side of the excavation at normal ground level and is used for excavating large open excavations such as basements when the depth is beyond the limit of the boom of a backhoe. It is commonly used for open cast mining operations.
- (v) **Clamshell** : It consists of two hinged half-buckets or jaws pivoted to a frame which is suspended by cable from a long jib of an excavation. The grab is used for deep excavations of limited area on all types of soil except rock. Crane and Grab is a variant of this type of equipment.

### 2.7.2 Tractor–based Equipment

It is a self–propelled crawler or wheeled machine used to exert a push or pull force through mounted equipment. It is designed either as attachments to normal tracked or wheeled tractors or as machines in which the earth moving attachments and the tractor are designed as a single integrated unit. A tractor, which is hydraulically operated, can be rigged as :

- (i) **Loaders** : It is used for loading, light dozing, scraping and grabbing operations, lifting and transporting the materials (loose earth, rubble, sand, gravel aggregate etc) at various sites through forward motion of the machine.
- (ii) **Tractor Shovel** : This consists of a tipping bucket at the front attached by strong pivoted arms or booms to the frame of the machine. It is used for stripping top soil, excavating against a face, bulldozing and for loading spoil or loose materials. It is similar to crawler dipper-shovel.
- (iii) **Trench Digger** : It operates on the same principle as a backhoe excavator except that the bucket is controlled by hydraulic rams instead of cables and pulleys.
- (iv) **Scraper** : Scrapers provide unique capability to excavate, load, haul and dump materials. Scrapers are available in various capacities by a number of manufacturers with options such as self – loading with elevators, twin engines or push-pull capability. They are cost effective where the haul distance is too long for bulldozers, yet too short for trucks. This distance typically ranges from 120 m to 1200 m; however, the economics should be evaluated for each project. Scraper has an open bowl with a cutting edge positioned between the axles, which cuts, loads, transports, discharges and spreads through forward motion of the machine. Loading through forward motion of the machine can be assisted by a powered mechanism (elevator) fixed to the scraper bowl.
- (v) **Bulldozer and Angle-dozer** : The most common equipment used for clearing and levelling activities is a bulldozer. The terms bulldozer is used to define a tractor mounted with a dozing blade. The bulldozer consists of a rectangular steel blade with renewable cutting edge set at right angles (capable of only tilting but not angling) to

## 2.28 ANTI-TERMITE TREATMENT

**2.28.0** Sub-terrestrial termites are responsible for most of the termite damage in buildings. Typically, they form nests or colonies underground. In the soil near ground level in a

stump or other suitable piece of timber in a conical or dome shaped mound. The termites find access to the super-structure of the building either through the timber buried in the ground or by means of mud shelter tubes constructed over unprotected foundations. Termite control in existing as well as new building structures is very important as the damage likely to be caused by the termites to wooden members of building and other household article like furniture, clothing, stationery etc. is considerable. Anti-termite treatment can be either during the time of construction i.e. pre-constructional chemical treatment or after the building has been constructed i.e. treatment for existing building. Prevention of the termite from reaching the super-structure of the building and its contents can be achieved by creating a chemical barrier between the ground, from where the termites come and other contents of the building which may form food for the termites. This is achieved by treating the soil beneath the building and around the foundation with a suitable insecticide.

### **2.28.1 Materials**

**2.28.1.0 Chemicals:** Any one of the following chemicals in water emulsion to achieve the percentage concentration specified against each chemical shall be used:

- (i) Chlorphiphos emulsifiable concentrate of 20%
- (ii) Lindane emulsifiable concentrate of 20%

Anti-termite treatment chemical is available in concentrated form in the market and concentration is indicated on the sealed containers. To achieve the specified percentage of concentration, Chemical should be diluted with water in required quantity before it is used. Graduated containers shall be used for dilution of chemical with water in the required proportion to achieve the desired percentage of concentration. For example, to dilute chemical of 20% concentration. 19 parts of water shall be added to one part of chemical for achieving 1% concentration.

Engineer-in-Charge shall procure the chemical of required concentration in sealed original containers directly from the reputed and authorized dealers, chemical shall be kept in the custody of the Engineer-in-Charge or his authorized representatives and issued for use to meet the day's requirements. Empty containers after washing and concentrated chemical left unused at the end of the day's work shall be returned to the Engineer-in-Charge or his authorized representative.

**For further detail refer CPWD specification volume 1, Clause 2.0**

**SUB HEAD : 3.0**  
**MORTARS**

**3.0 GENERAL**

Desirable properties of mortars for use in masonry are:

- (a) Workability
- (b) Water retentivity
- (c) Rate of stiffing
- (d) Strength
- (e) Resistance to rain penetration
- (f) Durability

**3.1 MATERIALS**

**3.1.1 Water**

**3.1.1.1** Water used for mixing and curing shall be clean and free from injurious quantities of alkalis, acids, oils, salts, sugar, organic materials, vegetable growth or other substance that may be deleterious to bricks, stone, concrete or steel. potable water is generally considered satisfactory for mixing. The Ph value of water shall be not less than 6. The following concentrations represent the maximum permissible values: (of deleterious materials in water).

- (a) **Limits of Acidity:** To neutralize 100ml sample of water, using phenolphthalein as an indicator, it should not require more than 5ml of 0.02 normal NaOH. The details of test shall be as given in IS 3025 (part 22).
- (b) **Limits of Alkalinity:** To neutralise 100ml sample of water, using mixed indicator, it should not require more than 25ml of 0.02 normal H<sub>2</sub>SO<sub>4</sub>. The details of tests shall be as given in IS 3025 (part 23).
- (c) **Percentage of Solids:** Maximum permissible limits of solids when tested in accordance with IS 3025 shall be as under:

Organic            200mg/ litre

Inorganic        3000 mg/ litre

Sulphates        400 mg/ litre

Chlorides        2000 mg/ litre.for concrete not containing embedded steel and 500 mg./ltr.for reinforced concrete work.

Suspended matter 2000 mg/ litre

The physical and chemical properties of ground water shall be tested along with soil investigation and if the water is not found conforming to the requirements of IS 456-2000, the tender documents shall clearly specify that the contractor has to arrange good quality water for construction indicating the source.

**3.1.1.2** Water found satisfactory for mixing is also suitable for curing. However, water used for curing shall not produce any objectionable stain or unsightly deposit on the surface.

**3.1.1.3** Sea water shall not be used for mixing or curing

**3.1.1.4** Water from each source shall be tested before the commencement of the work and thereafter once in every three months till the completion of the work. In case of ground water, testing shall also be done for different points of drawdown. Water from each source shall be got tested during the dry season before monsoon and again after monsoon.

**3.1.2 Cement**

**3.1.2.1** The cement used shall be any of the following grade and the type selected should be appropriate for the intended use.

(a) 33 grade ordinary Portland cement conforming to IS 269.

(b) 43 grade ordinary Portland cement conforming to IS 8112.

(c) 53 grade ordinary Portland cement conforming to IS 12269.

(d) Rapid hardening Portland cement conforming to IS 8041.

- (e) Portland slag cement conforming to IS 455.
- (f) Portland Pozzolana cement (flyash based) conforming to IS 1489 (Part 1).
- (g) Portland Pozzolana cement (calcined clay based) conforming to IS 1489 (part 2).
- (h) Hydrophobic cement conforming to IS 8043
- (i) Low heat Portland cement conforming to IS 12600.
- (j) Sulphate resisting Portland cement conforming to IS 12330
- (k) White cement conforming to IS 8042

Different types of cement shall not be mixed together. In case more than one type of cement is used in any work, a record shall be kept showing the location and the types of cement used.

**3.1.2.2 Caution in Use of Cement Grade 53 in Construction:** Because of the faster hydration process, the concrete releases heat of hydration at a much faster rate initially and release of heat is the higher in case of Grade. 53. The heat of hydration being higher, the chances of micro-cracking of concrete is much greater. Thus, during initial setting period of concrete, the higher heat of hydration can lead to damaging micro-cracking within the concrete which may not be visible at surface. This cracking is different from shrinkage cracks which occurs due to faster drying of concrete in windy conditions. The situation can be worse when we tend to increase the quantity of the cement in the concrete with a belief that such increases are better for both strength and durability of concrete. Thus, it is very essential to be forewarned that higher grade cement specially grade 53 should be used only where such use is warranted for making higher strength concrete and also where good Quality Assurance measures are in place, by which proper precaution are taken to relieve the higher heat of hydration through chilling of aggregates or by proper curing of concrete. There are instances where higher grade cement is being used even for low strength concrete, as, mortar or even for plastering. This can lead to unnecessary cracking of concrete/ surfaces. Another issue to be cautioned against is the tendency of the manufacturers to project Grade 53 cement as stronger cement, whereas Grade 33 or 43 are enough to produce the concrete of desired characteristic strength. The scenario of method of production of cement by various manufacturers should also be kept in mind while ordering various grades of cement. The ability to produce cements of particular fineness get fixed by the machinery installed by the manufacturers, and thus the ability to produce other various grades of cement by a particular manufacturer also gets limited. Whereas tendency today is to supply the consumer what he orders for by the manufacturers by simply stamping such grades on the bags. Thus, it is often observed that cement bags marked as grade 33 or 43 may really be containing cements of much higher grade.

**3.1.2.3 Compressive Strength :** Compressive strength requirement of each type of cement for various grades when tested in accordance with IS 4031 (part 6) shall be as under:

Sample	Strength in N/mm <sup>2</sup> not less than for		
	Gr. 33	Gr.43	Gr. 53
Age at testing			
72 + 1 hr	16	23	27
168 + 2 hrs	22	33	37
672 + 4 hrs	33	43	53

**3.1.2.4 Setting Time:** Setting time of cement of any type of any grade when tested by Vicat apparatus method described in IS 4031 shall conform to the following requirement:

- (a) Initial setting time: Not less than 30 minutes

(b) Final setting time: Not more than 600 minutes

**3.1.2.5 Supply :** The cement shall be packed in jute sacking bags conforming to IS 2580, double hessian bituminized (CRI type) or woven HDPE conforming to IS 11652. Woven polypropylene conforming to IS 11653, jute synthetic union conforming to IS: 12174, or any other approved composite bags, bearing the manufacturer's name or his registered trade mark if any, with grade batch no. and type of cement, with date of manufacturing of batch of cement. Every delivery of cement shall be accompanied by a producer's certificate conforming that the supplied cement conforms to relevant specifications. These certificates shall be endorsed to the Engineer-in-Charge for his record. Every consignment of cement must have identification marks on packages indicating date of manufacturing grade and type of cement batch no. etc. Cement brought to works shall not be more than 6 weeks old from the date of manufacture. Effective precautionary measures shall be taken to eliminate dust-nuisance during loading or transferring cement.

**3.1.2.6 Stacking and Storage :** Cement in bags shall be stored and stacked in a shed which is dry, leakproof and as moisture-proof as possible. Flooring of the shed shall consist of the two layers of dry bricks laid on well consolidated earth to avoid contact of cement bags with the floor. Stacking shall be done about 150 to 200 mm clear above the floor using wooden planks. Cement bags shall be stacked at least 450 mm clear off the walls and in rows of two bags leaving in a space of at least 600 mm between two consecutive rows. In each row the cement bags shall be kept close together so as to reduce air circulation. Stacking shall not be more than 10 bags high to avoid lumping under pressure. In stacks more than 8 bags high, the cement bags shall be arranged in header and stretcher fashion i.e. alternately lengthwise and crosswise so as to tie the stacks together and minimise the danger of toppling over. A typical arrangement for storing and stacking of cement is shown in Fig. 1. of sub-head of Carriage of Materials. Different types of cement shall be stacked and stored separately. Cement bags shall be stacked in a manner to facilitate their removal and use in the order in which they are received. For extra safety during monsoon, or when cement is expected to be stored for an unusually long period, each stack shall be completely enclosed by a water proofing membrane, such as polyethylene, which shall cover the top of the stack. Care shall be taken to see that the water proofing membrane is not damaged at any time during use. Storage of cement at the work site shall be at the contractor's expense and risk. Any damage occurring to cement due to faulty storage in contractor's shed or on account of negligence on his part shall be the liability of the contractor.

### **3.1.3 Fine Aggregate**

**3.1.3.1** Aggregate most of which passes through 4.75 mm IS sieve is known as fine aggregate. Fine aggregate shall consist of natural sand, crushed stone sand, crushed gravel sand stone dust or marble dust, fly ash and broken brick (Burnt clay). It shall be hard, durable, chemically inert, clean and free from adherent coatings, organic matter etc. and shall not contain any appreciable amount of clay balls or pellets and harmful impurities e.g. iron pyrites, alkalis, salts, coal, mica, shale or similar laminated materials in such form or in such quantities as to cause corrosion of metal or affect adversely the hardening, the strength, the durability or the appearance of mortar, plaster or concrete. The sum of the percentages of all deleterious material shall not exceed 5%. Fine aggregate must be checked for organic impurities such as decayed vegetation humps, coal dust etc. in accordance with the procedure prescribed in Appendix 'A' of Chapter 3.

**3.1.3.2 Silt Content :** The maximum quantity of silt in sand as determined by the method prescribed in Appendix 'C' of Chapter 3 shall not exceed 8%.

Fine aggregate containing more than allowable percentage of silt shall be washed as many times as directed by Engineer-in-charge so as to bring the silt content within allowable limits for which nothing extra shall be paid.

**3.1.3.3 Grading :** On the basis of particle size, fine aggregate is graded in to four zones. The grading when determined in accordance with the procedure prescribed in Appendix 'B' of Chapter 3 shall be within the limits given in Table 3.1 below. Where the grading falls outside the limits of any particular grading zone of sieves, other than 600 micron IS sieve, by a total amount not exceeding 5 per cent, it shall be regarded as falling within that grading zone.

**TABLE 3.1**  
**Fine Aggregates**  
**(Clause 3.1.3)**

IS Sieve	Percentage passing for			
	Grading Zone I	Grading Zone II	Grading Zone III	Grading Zone IV
10 mm	100	100	100	100
4.75 mm	90-100	90-100	90-100	95-100
2.36 mm	60-95	75-100	85-100	95-100
1.18 mm	30-70	55-90	75-100	90-100
600 microns	15-34	35-59	60-79	80-100
300 microns	5-20	8-30	12-40	15-50
150 microns	0-10	0-10	0-10	0-15

**Note 1:** For crushed stone sands, the permissible limit on 150 micron sieve is increased to 20 per cent. This does not affect the 5 per cent allowance permitted in 3.1.3.4 (e) (1) applying to other sieves.

**Note 2:** Allowance of 5% permitted in 3.1.3.4 (e) (1) can be split up, for example it could be 1% on each of three sieves and 2% on another or 4% on one sieve and 1% on another.

**Note 3:** Fine aggregate conforming to Grading Zone IV shall not be used in reinforced cement concrete unless tests have been made to ascertain the suitability of proposed mix proportions.

**Note 4:** Sand requiring use for mortar for plaster work shall conform to IS 1542 and for masonry work shall conform to IS 2116.

**3.1.3.4** Type and grading of fine aggregate to be used shall be specified. It shall be coarse sand, fine sand, stone dust or marble dust, fly ash and surkhi. Use of sea sand shall not be allowed, unless otherwise specified.

- (a) Coarse sand shall be either river sand or pit sand or a combination of the two. Badarpur sand available in Delhi generally falls in category of pit sand. It shall be clean, sharp, angular, gritty to touch and composed of hard silicious material. Its grading shall fall within the limits of grading zone I, II, III of Table 3.1. Grading of sand shall conform to IS 2116 for use in Masonry work.
- (b) Fine sand shall be either river sand or pit sand or a combination of the two. Its grading shall fall within the limits of Grading zone IV of Table 3.1. As a guideline, fine sand conforming to grading Zone IV can be generally obtained in Delhi by mixing one part of Badarpur sand and two parts of jamuna Sand (by volume). Grading of sand shall conform to IS 1542 for use in plaster work.
- (c) Stone dust shall be obtained by crushing hard stones or gravel. Its grading shall fall within the limits of grading Zone, I, II, or III of Table 3.1.
- (d) Marble dust shall be obtained by crushing marble. Its grading shall fall within the limits of Grading Zone IV of Table 3.1. Grading of Marble dust for use in Mortar shall be as per following table.

### Grading of Marble Dust

<i>IS Sieve</i>	<i>Percentage Passing</i>
10 mm	100
4.75 mm	95-100
2.36 mm	95-100
1.18 mm	90-100
600 micron	80-100
300 micron	15-50
150 micron	0-15

- (e) Sand for Masonry Mortar and for Plaster- Sand shall consist of natural sand, crushed stone sand or crushed gravel sand or a combination of any of these. Sand shall be hard durable, clean and free from adherent coating and organic matter and shall not contain the amount of clay, silt and fine dust more than specified as under.

**Deleterious Material:** Sand shall not contain any harmful impurities such as iron, pyrites, alkalis, salts, coal or other organic impurities, mica, shale or similar laminated materials, soft fragments, sea shale in such form or in such quantities as to affect adversely the hardening, strength or durability of the mortar. The maximum quantities of clay, fine silt, fine dust and organic impurities in the sand / Marble dust shall not exceed the following limits:

- (1) Clay, fine silt and fine dust when determined in accordance within IS 2386 (Part II). In natural sand or crushed gravel sand & crushed stone sand Not more than 5% by mass
- (2) Organic impurities when determined in accordance with IS 2386 (Part II) Colour of the liquid shall be lighter than that indicated by the standard specified in IS 2386 (Part II).

Grading of sand for use in masonry mortar shall be conforming to IS 216 (Table 3.2 below).

Grading of sand for use in plaster shall be conforming to IS 1542 (Table 3.2 below):

**TABLE 3.2**  
**Grading of Sand for use in Masonry Mortar and Plaster**

<i>Grading of sand for use in masonry mortar</i>		<i>Grading of sand for use in plaster</i>	
<i>IS Sieve Designation</i>	<i>Percentage passing by mass</i>	<i>IS Sieve Designation</i>	<i>Percentage passing by mass</i>
10 mm	100	10 mm	100
4.75 mm	100	4.75 mm	95 to 100
2.36 mm	90 to 100	2.36 mm	95 to 100

<i>Grading of sand for use in masonry mortar</i>		<i>Grading of sand for use in plaster</i>	
<i>IS Sieve Designation</i>	<i>Percentage passing by mass</i>	<i>IS Sieve Designation</i>	<i>Percentage passing by mass</i>
1.18 mm	70 to 100	1.18 mm	90 to 100
600 micron	40 to 100	600 micron	80 to 100
300 micron	5 to 70	300 micron	20 to 65
150 micron	0 to 15	150 micron	0 to 50

**Note:** For crushed stone sands, the permissible limit on 150 micron IS Sieve is increased to 20%, this does not affect the 5% allowance as per IS 2386 (Part 1).

**3.1.3.5 Bulking:** Fine aggregate, when dry or saturated, has almost the same Volume but dampness causes increase in volume. In case fine aggregate is damp at the time of proportioning the ingredients for mortar or concrete, its quantity shall be increased suitably to allow for bulking, which shall be determined by the method prescribed in Appendix 'D' of Chapter 3.0 Table 3.3 gives the relation between moisture content and percentage of bulking for guidance only.

**TABLE 3.3**

<i>Moisture content % age</i>	<i>Bulking % age (by volume)</i>
2	15
3	20
4	25
5	30

**3.1.3.6 Stacking:** Fine aggregate shall be so stacked as to prevent dust and foreign matter getting mixed up with it as far as practically possible. Marble dust in dry condition shall be collected in bags and properly staked so as not to form lumps, suitable arrangements shall be made to protect it from moisture similar to those adopted for stacking of cement bags.

**3.1.3.7 Measurements:** As the fine aggregate bulks to a substantial extent when partially wet, measurements shall be taken when the stacks are dry or appropriate allowance made for bulking.

### **3.1.4 Broken Brick (Burnt Clay) Fine Aggregate**

**3.1.4.1** Broken Brick (Burnt Clay) Fine Aggregate, also known as Surkhi, shall be made by grinding well burnt (but not under or over burnt) broken bricks as specified in IS 3068-1986. It shall not contain any harmful impurities, such as iron pyrites, salts, coal, mica, shale or similar laminated or other materials in such form of quantity as to adversely affect hardening, strength, durability or appearance of the mortar. The maximum quantities of clay, fine silt, fine dust and organic impurities in surkhi (all taken together) shall not exceed five per cent by weight. The particle size grading of surkhi for use in lime mortars shall be within the limits specified in Table 3.4.

**TABLE 3.4**

<i>IS Sieve Designation</i>	<i>Percentage passing (by wt)</i>
4.75 mm	100
2.36 mm	90-100
1.18 mm	70-100
600 microns	40-100
300 microns	5-70
150 microns	0-15

**3.1.4.2 Stacking:** Surkhi shall be stacked on a hard surface or platform so as to prevent the admixture of clay, dust, vegetation and other foreign matter. It shall be also protected from rain and dampness and kept under adequate coverings.

**3.1.4.3 Measurements:** Surkhi shall be measured in regular stacks in cubic metres. Alternatively it may be measured by weight when supplied in bags.

### **3.1.5 Fly Ash**

Fly ash is finely divided residue resulting from the combustion of pulverized coal in boilers. Fly ash is the pulverized fuel ash extracted from the flue gases by any suitable process such as cyclone separation or electrostatic precipitation. The ash collected from the bottom of boilers is termed as bottom ash. Fly ash is finer than bottom ash. Siliceous fly ash (ASTM Class F) containing calcium oxide less than 10% by mass is normally produced from burning anthracite or bituminous coal and possesses pozzolanic properties. Calcareous fly ash (ASTM Class C) is produced by burning lignite or sub-bituminous coal and contains calcium oxide more than 10% by mass; the content could be as high as 25%. This fly ash has both hydraulic and pozzolanic properties. It shall be clean and free from any contamination of bottom ash, grit or small pieces of pebbles. It is obligatory on the part of supplier/manufacture that the fly ash conforms to the requirements if mutually agreed upon & shall furnish a certificate to this effect to the purchaser or his representative.



**3.1.5.1 Characteristics:** The physical requirements of fly-ash shall be as specified in Annexure 'E' of Chapter 3. The chemical properties of fly ash shall be as per IS 3 812 (part 1 & 2) depending on the usage.

**3.1.5.2 Stacking:** Fly ash shall be protected from dirt collecting on it.

**3.1.5.3 Measurements:** Fly ash shall be measured in regular stacks in cubic metres. Alternatively it may be measured by weight when supplied in bags.

## **3.2 PREPARTATION OF MORTARS AND ITS GRADE**

### **3.2.0 Grade of Masonry Mortar**

The grade of masonry mortar will be defined by its compressive strength in N/mm<sup>2</sup> at the age of 28 days as determined by the standard procedure detailed in IS 2250.

**3.2.0.1** For proportioning the ingredients by volume, the conversion of weight into volume shall be made on the following basis:

(a) Burnt Clay Pozzolana	860 Kg/cum
(b) Coarse Sand (dry)	1280 kg/cum
(c) Fine sand (dry)	1600 kg/ cum
(d) Fly Ash	590 kg/ cum

For details of grades and criteria for selection of Masonry mortars see Appendix 'F' of chapter-3.

### **3.2.1 Cement Mortar**

**3.2.1.1** This shall be prepared by mixing cement and sand with or without the addition of pozzolana in specified proportions as per Appendix 'F'.

**3.2.1.2 Proportioning:** Proportioning on weight basis shall be preferred taking into account specific gravity of sand and moisture content . Boxes of suitable size shall be prepared to facilitate proportioning on weight basis. Cement bag weighting 50 kg shall be taken as 0.035 cubic metre. Other ingredients in specified proportion shall be measured using boxes of size 40 x 35 x 25 cm. Sand shall be measured on the basis of its dry volume in the case of volumetric proportioning.

### **3.2.1.3 Mixing**

**3.2.1.3.1** The mixing of mortar shall be done in mechanical mixers operated manually or by power as decided by Engineer-in-Charge. The Engineer-in-Charge may, however, permit hand mixing at his discretion taking into account the nature, magnitude and location of the work and practicability of the use of mechanical mixers or where item involving small quantities are to be done or if in his opinion the use of mechanical mixer is not feasible. In cases, where mechanical mixers are not to be used, The contractor shall take permission of the Engineer-in-Charge in writing before the commencement of the work.

(a) Mechanical Mixing: Cement and sand in the specified proportions shall be mixed dry thoroughly in a mixer. Water shall then be added gradually and wet mixing continued for at least three minutes. only the required quantity of water shall be added which will produce mortar of workable consistency but not stiff paste. Only the quantity of mortar, which can be used within 30 minutes of its mixing shall be prepared at a time. Mixer shall be cleaned with water each time before suspending the work.

(b) Hand Mixing: The measured quantity of sand shall be leveled on a clean masonry platform and cement bags emptied on top. The cement and sand shall be thoroughly mixed dry by being turned over and over, backwards and forwards, several times till the mixture is of a uniform colour. The quantity of dry mix which can be used within 30 minutes shall then be mixed in a masonry trough with just sufficient quantity of water to bring the mortar to a stiff paste of necessary working consistency.

**3.2.1.4 Precautions:** mortar shall be used as soon as possible after mixing and before it begins to set, and in any case within half hour, after the water is added to the dry mixture.

### **3.2.2 Cement Flyash Sand Mortar**

**3.2.2.1** This shall be prepared by mixing cement, flyash and sand in specified proportions as per Appendix G. Mixing shall be done in a mechanical mixer (operated manually or by power) unless otherwise permitted by the Engineer-in-Charge in writing. The Engineer-in-Charge may, however, permit hand mixing at his discretion, taking into account the nature, magnitude and location of the work and practicability of the use of mechanical mixer or where items involving small quantities are to be done or if in his opinion the use of mechanical mixer is not feasible. In case, where mechanical mixer is not to be used, the contractor shall take permission of the Engineer-in-Charge in writing before the commencement of the work.

**3.2.2.2 Proportioning:** Proportioning on weight basis shall be preferred taking into account specific gravity of Fly Ash, sand and moisture content. Boxes of suitable size shall be prepared to facilitate proportioning on weight basis. Cement bag weighting 50 kg shall be taken as 0.035 cubic metre. Other ingredients in the specified proportions shall be measured using boxes of suitable sizes. Sand and flyash shall be measured on the basis of their dry volume in the case of volumetric proportioning.

#### **3.2.2.3 Mixing**

- (a) Mechanical Mixing: Sand and flyash in the specified proportions shall be mixed dry in a mixer and then the specified quantity of cement shall be added and mixed dry thoroughly. Water shall then be added gradually and wet mixing continued for atleast one minute. Water shall be just sufficient to bring the mortar to the consistency of a workable paste. Only the quantity of mortar which can be used within 30 minutes of its mixing shall be prepared at a time.
- (b) Hand Mixing: The measured quantity of sand and flyash shall be mixed dry on a clean masonry platform before adding specified quantity of cement to it. The resulting mixture of cement, sand and flyash shall then be mixed thoroughly being turned over and over, backward several times till the mixture is of a uniform colour. The quantity of dry mix which can be used within 30 minutes shall then be mixed in a clean watertight masonry trough with just sufficient quantity of water, to bring the mortar to a stiff paste of necessary working consistency.

**3.2.2.4 Precautions:** Shall be same as specified in 3.2.1.4.

**Note:- For further detail refer CPWD specification volume 1, Sub Head 3.0**

**SUB HEAD : 4.0  
CONCRETE WORK**

**4.1. MATERIAL**

Water, cement, fine aggregate or sand, surkhi, and fly ash shall be as specified in Chapter 3.0 – Mortar.

**4.1.1 Coarse Aggregate**

**4.1.1.1 General:** Aggregate most of which is retained on 4.75 mm IS Sieve and contains only as much fine material as is permitted in IS 383 for various sizes and grading is known as coarse aggregate. Coarse aggregate shall be specified as stone aggregate, gravel or brick aggregate and it shall be obtained from approved/ authorized sources.

(a) **Stone Aggregate:** It shall consist of naturally occurring (uncrushed, crushed or broken) stones. It shall be hard, strong, dense, durable and clean. It shall be free from veins, adherent coating, injurious amounts of disintegrated pieces, alkali, vegetable matter and other deleterious substances. It shall be roughly cubical in shape. Flaky and elongated pieces shall be avoided. It shall conform to IS 383 unless otherwise specified.

**4.1.1.2 Deleterious Material:** Coarse aggregate shall not contain any deleterious material, such as pyrites, coal, lignite, mica, shale or similar laminated material, clay, alkali, soft fragments, sea shells and organic impurities in such quantity as to affect the strength or durability of the concrete. Coarse aggregate to be used for reinforced cement concrete. Coarse aggregate to be used for reinforced cement concrete shall not contain any material liable to attack the steel reinforcement. Aggregates which are chemically reactive with alkalies of cement shall not be used. The maximum quantity of deleterious material shall not be more than five percent of the weight of coarse aggregate when determined in accordance with IS 2386.

**4.1.1.3 Size and Grading**

(i) Stone aggregate and gravel: It shall be either graded or single sized as specified. Nominal size and grading shall be as under:-

(a) Nominal sizes of graded stone aggregate or gravel shall be 40, 20, 16, or 12.5 mm as specified. For any one of the nominal sizes, the proportion of other sizes as determined by

1.1 the method prescribed in Appendix 'A' of Chapter 4 shall be in accordance with Table 4.1

**TABLE 4.1  
Graded Stone Aggregate or Gravel**

IS Sieve Designation	Percentage passing (by weight) for nominal size of			
	40 mm	20 mm	16 mm	12.5 mm
80 mm	100	-	-	-
63 mm	-	-	-	-
40 mm	95 to 100	100	-	-
20 mm	30 to 70	95 to 100	100	100
16 mm	-	-	90 to 100	-
12.5 mm	-	-	-	90 to 100
10 mm	10 to 35	25 to 55	30 to 70	40 to 85
4.75 mm	0 to 5	0 to 10	0 to 10	0 to 10

(b) Nominal sizes of single sized stone aggregate or gravel shall be 63, 40, 20, 16, 12.5 or 10 mm as specified. For any one of the nominal size, the proportion of other sizes as determined by the method prescribed in Appendix 'A' of Chapter 4 shall be in accordance with Table 4.2.

**TABLE 4.2**  
**Single Sized (Ungraded) Stone Aggregate or Gravel**

IS Sieve Designation	Percentage passing (by weight) for nominal size of					
	63 mm	40 mm	20 mm	16 mm	12.5 mm	10 mm
80 mm	100	-	-	-	-	-
63 mm	85-100	100	-	-	-	-
40 mm	0-30	85-100	100	-	-	-
20 mm	0- 5	0-20	85-100	100	-	-
16 mm	-	-	-	85-100	100	-
12.5 mm	-	-	-	-	85-100	100
10 mm	0-5	0-5	0-20	0-30	0-45	85-100
4.75 mm	-	-	0-5	0-5	0-10	0-20
2.36 mm	-	-	-	-	-	0-5

- (c) When stone aggregate or gravel brought to site is single sized (ungraded), it shall be mixed with single sized aggregate of different sizes in the proportion to be determined by field tests to obtain graded aggregate of specified nominal size. For the required nominal size, the proportion of other sizes in mixed aggregate as determined by method prescribed in Appendix 'A' of Chapter 4 shall be in accordance with Table 4.1. Recommended proportions by volume for mixing of different sizes of single size (ungraded) aggregate to obtain the required nominal size of graded aggregate are given in Table 4.3

**TABLE 4.3**  
**Single Sized (Ungraded) Stone Aggregate or Gravel**

Cement concrete	Nominal size of graded aggregate required	Parts of single size aggregate of size				
		50 mm	40 mm	20 mm	12.5 mm	10 mm
(1)	(2)	(3)	(4)	(5)	(6)	(7)
1:6:12	63	9	-	3	-	-
1:6:12	40	-	9	3	-	-
1:5:10	63	7.5	-	2.5	-	-

(1)	(2)	(3)	(4)	(5)	(6)	(7)
1:5:10	40	-	7.5	2.5	-	-
1:4:8	63	6	-	2	-	-
1:4:8	40	-	6	2	-	-
1:3:6	63	4.5	-	1.5	-	-
1:3:6	40	-	4.5	1.5	-	-
1:3:6	20	-	-	4.5	-	1.5
1:2:4	40	-	2.5	1	-	1.5
1:2:4	20	-	-	3	-	1
1:2:4	12.5	-	-	-	3	1
1: 1½:3	20	0	0	2	-	1

**Note:**

- (i) The proportions indicated in Table 4.3 above are by volume when considered necessary, these proportions may be varied marginally by Engineer-in-Charge after making sieve analysis of aggregate brought to site for obtaining required graded aggregate.
- (ii) No adjustments in rate shall be made for any variation in the proportions so ordered by the Engineer-in-Charge. If single size coarse aggregate are not premixed at site to obtain the graded coarse aggregate required for the mix, the volume of single size aggregates required for the mix shall be suitably increased to account for reduction in total volume at the site of mixing.

- (ii) Brick Aggregate: Nominal size of brick aggregate shall be 40 mm and its grading shall be as specified in Table 4.4 when tested for sieve analysis for the method prescribed in Appendix 'A' of Chapter 4.0.

**TABLE 4.4**  
**Brick Aggregate**

<i>IS Sieve Designation</i>	<i>Percentage passing (by weight)</i>
75 mm	100
37.5 mm	95-100
20.0 mm	45-100
4.75 mm	0.50

**4.1.1.4 Stacking:** Aggregate shall be stacked on a hard, dry and level patch of ground. When stackpiling, the aggregate shall not form pyramids resulting in segregation of different sized materials. It shall be stacked separately according to nominal size of coarse aggregates. Stacking shall be done in regular stacks, of height not exceeding 100 cm.

**4.1.1.5 Testing:** Coarse aggregate shall be tested for the followings (as per IS 2386)

- Determination of particle size and shape (Appendix 'A' of Chapter 4)
- Estimation of organic impurities (as per IS 2386 - Part II)
- Surface moisture (Appendix 'B' of Chapter 4)
- Determination of 10% fine value (Appendix 'C' of Chapter 4)

**4.1.1.6 Measurements:** The aggregates shall be measured in stacks and paid for after making a deduction of 7.5% of the gross measurements of stacks in respect of aggregates of nominal size 40 mm and above. No deduction from the gross measurements of the stacks is to be made in respect of aggregate of nominal size below 40 mm.

#### **4.1.2 Chemical Admixtures**

When required, admixtures of approved quality shall be mixed with concrete, as specified. The admixtures shall conform to IS 9103 and as specified in Chapter 5 - R.C.C.

**4.1.2.1 Admixtures** may be any one of the following classes for use in concrete:-

- Water Reducing Admixtures
- Retarding Admixtures
- Accelerating Admixtures.
- Water Reducing and Retarding Admixtures.
- Water Reducing and Accelerating Admixtures.
- Permeability Reducing (water proofing) Admixtures.

**4.1.2.2 Liquid Admixtures:** Admixtures introduced into the concrete as liquids generally fall into the following categories.

- Air Entraining.
- Water Reducing.
- Water Reducing Retarders.
- Retarders.
- Water Reducing Accelerators.
- Accelerators.

**4.1.2.3 Dosage** of these admixtures may vary according to manufacturers specification.

**4.1.2.4** Two or more admixtures may not be compatible in the same solution. It is therefore mandatory that when two admixtures manufactured by the same manufacturers is being used simultaneously, the manufacturer shall certify their compatibility. In case the two or more admixtures are produced by different manufacturers, then, before their use in concrete, test

shall be performed by the manufacturer to establish their compatibility, all such test reports shall be furnished to the Engineer-in-Charge for his approval before their use in concrete.

**4.1.2.5** Some admixture may be in the form of powder, particle or high concentration liquids which may require mixing with water prior to dosing. Under these conditions water in solution shall be considered as part of total water content in the batch in order to maintain the water-cement ratio.

**4.1.2.6** Admixture manufacturer's recommendation shall be carefully followed so as to ensure complete solution of the product or to prepare a standard solution of uniform strength for easier use.

**4.1.2.7** Certain admixtures may contain significant amounts of finely divided insoluble materials or active ingredients which may or may not be readily soluble. It is essential for such admixtures that precautions be taken to ensure that these constituents be kept in a state of uniform suspension before actual batching. When relatively small amounts of powdered admixtures are to be used directly, these shall be pre-blended with cement.

**4.1.2.8** Admixtures are sold under various trade names and may be in the form of liquids or powders. The proprietary name and the net quantity of content shall be clearly indicated in each package or container of admixtures. The admixtures shall be uniform within each batch and uniform between all batches.

**4.1.2.9** No admixtures shall be accepted for use in concrete unless these are tested in accordance with IS 9103 and the test results are approved by the Engineer-in-Charge.

## 4.2. CEMENT CONCRETE

### 4.2.1 Grades of Cement Concrete

The concrete shall be in grade designated as under:

**TABLE 4.5**  
Grades of Concrete

Group	Grade Designation	Specified characteristic compressive strength of 150 mm Cube at 28 Days in N/mm <sup>2</sup>
(1)	(2)	(3)
Ordinary Concrete	M10	10
	M15	15
	M20	20
Standard Concrete	M25	25
	M30	30
	M35	35
	M40	40
	M45	45
	M50	50
	M55	55
High Strength Concrete	M60	60
	M65	65
	M70	70
	M75	75
	M80	80

#### Notes :

1. In the designation of concrete mix M refers to the mix and the number to the specified compressive strength of 150 mm size cube at 28 days, expressed in N/mm<sup>2</sup>.

2. For concrete of compressive strength greater than M55, design parameters given in the standard may not be applicable and the values may be obtained from specialized literatures and experimental results.

**4.2.1.1** The characteristic strength is defined as the strength of material below which not more than 5percent of the test results are expected to fall.

**TABLE 4.6**  
**Minimum Cement Content, Maximum Water-Cement Ratio and Minimum Grade of Concrete for Different Exposures with Normal Weight Aggregates of 20 mm Nominal; Maximum Size (Clause 4.2.1.1)**

Sl. No.	Exposure	Plain Concrete			Reinforced Concrete		
		Minimum Cement Content kg/m <sup>3</sup>	Maximum Free Water Cement Ratio	Minimum Grade of Concrete	Minimum Cement Content kg/m <sup>3</sup>	Maximum Free Water-Cement Ratio	Minimum Grade of Concrete
(1)	(2)	(3)	(4)	(5)	(6)	(7)	(8)
(i)	Mild	220	0.60	-	300	0.55	M20
(ii)	Moderate	240	0.60	M15	300	0.50	M25
(iii)	Severe	250	0.50	M20	320	0.45	M30
(iv)	Very Severe	260	0.45	M20	340	0.45	M35
(v)	Extreme	280	0.40	M25	360	0.40	M40

**Notes:**

1. Cement content prescribed in this Table is irrespective of the grades of cement. The additions such as fly or ground granulated blast furnace slag may be taken into account in the concrete composition with respect to the cement content and water-cement ratio, if the suitability is established and as long as the maximum amounts taken into account do not exceed the limit of pozzolona and slag specified in IS 1489 (Part 1) and IS 455 respectively.
2. Minimum grade for plain concrete under mild exposure condition is not specified.
3. The above minimum cement content and maximum water cement ratio apply only to 20 mm nominal maximum size aggregate. For other sizes of aggregate, these should be changed as per The minimum grade of concrete for plain and reinforced concrete shall be as per

**4.2.1.2** Concrete of grades lower than those given in may be used for lean concrete, foundation for masonry walls or temporary reinforced concrete construction.

**4.2.2 Workability of Concrete**

**4.2.2.1** The concrete mix proportion chosen should be such that the concrete is of adequate workability for the placing conditions of the concrete and can properly be compacted with the means available Suggested ranges of workability of concrete measured in accordance with IS 1199 are given below:

Placing Conditions	Degree of Workability	Slump (mm)
(1)	(2)	(3)
Blinding concrete: shallow sections: Pavements using pavers	Very low	See 4.2.2.2
Mass concrete: Lightly reinforced sections in slabs, beams, wall, columns, : floors	Low	25-75
Hand placed pavements: canal lining; Strip footing	Medium	50-100
Heavily reinforced sections in slabs, beams, walls, columns:		
Slip form work: Pumped concrete	Medium	75-100
Trench fill	High	100-150
Tremie concrete	Very High	See 4.2.2.3

**Note:-** For most of the placing conditions, internal vibrators (needle vibrators) are suitable. The diameter of the needle shall be determined based on the density and spacing of reinforcement bars and thickness of sections For tremie concrete, vibrators are not required to be used.

**4.2.2.2** In the ‘very low’ category of workability where strict control is necessary, for example, pavement quality concrete, measurement of workability by determination of compacting factor will be more appropriate than slump ( see IS 1199) and a value of compacting factor of 0.75 to 0.80 is suggested.

**4.2.2.3** In the ‘very high’ category of workability, measurement of workability by determination of flow will be appropriate (see IS 9103).

### 4.2.3 Concrete Mix Proportioning

**4.2.3.1** The determination of the proportion of cement, aggregate and water to attain the required strength shall be made as follows:

(a) By designing the concrete mix: such concrete shall be called ‘Design mix concrete’, for details reference may be made to RCC Chapter.

(b) By adopting nominal concrete mix: such concrete shall be called ‘Nominal mix concrete’ Design mix concrete is preferred to nominal mix. If design mix concrete cannot be used for any reason on the work for grades of M20 or lower, nominal mixes may be used with the permission of Engineer-in-Charge, which, however, is likely to involve a higher cement content.

**4.2.3.2 Nominal Mix Concrete:** Nominal Mix Concrete may be used for concrete of M20 or lower. The proportions of materials for nominal mix concrete shall be in accordance with The cement content of the mix specified in Table 4.7 for any nominal mix shall be proportionately increased if the quantity of water in the mix has to be increased to overcome the difficulty or placement and compaction, so that the water cement ratio as specified is not exceeded.

**TABLE 4.7**  
**Proportions for Nominal Mix Concrete**  
*(Clause 4.2.3.2)*

<i>Grade of Concrete</i>	<i>Total Quantity of Dry Aggregates by Mass per 50 kg of cement, to be taken as the Sum of the Individual Masses of Fine and Coarse Aggregates, Kg.</i>	<i>Proportion of Fine Aggregate to Coarse Aggregate (by Mass)</i>	<i>Quantity of Water per 50 kg of Cement, max Ltr.</i>
<i>(1)</i>	<i>(2)</i>	<i>(3)</i>	<i>(4)</i>
M5	800	Generally 1:2 but subject to an upper limit of 1: 1 ½ and a lower limit of 1:2 ½	60
M7.5	625		45
M10	480		34
M15	330		32
M20	250		30

**Note :** - The proportion of the fine to coarse aggregate should be adjusted from upper limit progressively as the grading of fine aggregate becomes finer and the maximum size of coarse aggregate becomes larger Graded coarse aggregate shall be used.

**Note :** - Quantity of water required from durability point of view may be less than the value given above.

**Example**

For an average grading of fine aggregate (that is, Zone II of Table 4 of IS 383), the proportions shall be 1:1 ½ , 1:2 and 1:2 ½ for maximum size of aggregates 10 mm, 20 mm and 40 mm respectively.



#### **4.2.4 Batching**

To avoid confusion and error in batching, consideration should be given to using the smallest practical number of different concrete mixed on any site or in any one plant. In batching concrete, the quantity of both cement and aggregate shall be determined by mass; admixture, if solid, by mass: liquid admixture may however be measured in volume or mass: water shall be weighed or measured by volume in a calibrated tank Ready-mixed concrete supplied by ready-mixed concrete plant shall be preferred. For large and medium project sites the concrete shall be sourced from ready-mixed concrete plants or from on site or off site batching and mixing plants (see IS 4926).

**4.2.4.1** Except where it can be shown to the satisfaction of the Engineer-in-Charge that supply of properly graded aggregate of uniform quality can be maintained over a period of work, the grading aggregate should be controlled by obtaining the coarse aggregate in different sizes and blending them in the right proportions when required, the different sizes being stocked in separate stock-piles. The material should be stock-piled for several hours preferably a day before use. The grading of coarse and fine aggregate should be checked as frequently as possible, the frequency for a given job being determined by the Engineer-in-Charge to ensure that the specified grading is maintained.

**4.2.4.2** The accuracy of the measuring equipment shall be within + 2 percent of the quantity of cement being measured and within + 3 percent of the quantity of aggregate, admixtures and water being measured.

**4.2.4.3** Proportion/Type and grading of aggregates shall be made by trial in such a way so as to obtain densest possible concrete. All ingredients of the concrete should be used by mass only.

**4.2.4.4** Volume batching may be allowed only where weigh-batching is not practicable and provided accurate used in concrete have earlier been established. Allowance for bilking shall be made in accordance with IS 2386 (Part 3). The mass volume relationship should be checked as frequently as necessary, the frequency for the given job being determined by Engineer-in-Charge to ensure that the specified grading is maintained.

**4.2.4.5** It is important to maintain the water cement ratio constant at its correct value. To this end, determination of moisture contents in both fine and coarse aggregates shall be made as frequently as possible, the frequency for a given job being determined by the Engineer-in-Charge according to weather conditions. The amount of the added water shall be adjusted to compensate for any observed variations in the moisture contents. For the determination of moisture content in the aggregates, IS 2386 (Part 3) may be referred to. To allow for the variation in mass for aggregate due to variations in their moisture content, suitable adjustments in the masses of aggregates shall be made. In the absence of exact data, only in the case of nominal mixes, the amount of surface water may be estimated from the values given in Table 4.8.

**TABLE 4.8**  
**Surface Water Carried by Aggregate**  
*(Clause 4.2.4.5)*

Sl No.	Aggregate	Approximate Quantity of Surface Water Percent by mass	Approximate Quantity of Surface Water l/m <sup>3</sup>
(1)	(2)	(3)	(4)
(i)	Very wet sand	7.5	120
(ii)	Moderately wet sand	5.0	80
(iii)	Moist sand	2.5	40
(iv)	<sup>1)</sup> Moist gravel or crushed rock	1.25-2.5	20-40

<sup>1)</sup> Coarser the aggregate, less the water it will carry.

**4.2.4.6** No substitutions in materials used on the work or alteration in the established proportions, except as permitted in 4.2.4.4 and 4.2.4.5 shall be made without additional tests to show that the quality and strength of concrete are satisfactory.

### 4.2.5 Mixing

Concrete shall be mixed in mechanical batch type concrete mixers conforming to IS 1791 having two blades and fitted with power loader (lifting hopper type). Half bag mixers and mixers without lifting hoppers shall not be used for mixing concrete. In exceptional circumstances, such as mechanical breakdown of mixer, work in remote areas or power breakdown and when the quantity of concrete work is very small, hand mixing may be done with the specific prior permission of the Engineer-in-Charge in writing subject to adding 10% extra cement. When hand mixing is permitted, it shall be carried out on a water tight platform and care shall be taken to ensure that mixing is continued until the concrete is uniform in colour and consistency. Before mixing the brick aggregate shall be well soaked with water for a minimum period of two hours and stone aggregate or gravel shall be washed with water to remove, dirt, dust and other foreign materials. For guidance, the mixing time may be 1 1/2 to 2 minutes, for hydrophobic cement it may be taken as 2 1/2 to 3 minutes.

**4.2.5.1 Power Loader:** Mixer will be fitted with a power loader complying with the following requirements.

(a) The hopper shall be of adequate capacity to receive and discharge the maximum nominal batch of unmixed materials without spillage under normal operating conditions on a level site.

**Note:** In such a case the volume of the maximum nominal batch of mixed material is 50% greater than the nominal mixed batch capacity.

(b) The minimum inside width of the feeding edge of the hopper shall be as specified below in Table 4.9.

**TABLE 4.9**

<i>Nominal size of mixer (T, NT or R). litre</i>	<i>Minimum inside width of hopper feeding edge</i>
140	1.0
200	1.1
280	1.2
375	1.4
500	1.5
1000	2.0

T = Tilting;

NT = Non-tilting;

R = Reverse

(c) The design of the loader shall be such that it allows the loading hopper to be elevated to such a height that the centre line of the chute plate of the hopper when in discharge position, is at an angle of not less than 50° to the horizontal. A mechanical device to aid discharge of the contents as quickly as possible from the hopper to the drum may also be provided. Even when a mechanical device is provided, it is recommended that the angle of centre line of the chute plate of the hopper when in discharge position, should be as larger as practicable,

preferably not less than 40° to horizontal. (d) When the means of raising and lowering the loading hopper includes flexible wire ropes winding on to a drum or drums, the method of fastening the wire to rope to the drums shall be such as to avoid, as far as possible any tendency to cut the strands of the ropes and the fastening should preferably be positioned clear of the barrel of the drum for example, outside the drums flange When the loading hopper is lowered to its normal loading position, these should be at least one and a half drums of rope on the drum.c) The design of the loader shall be such that it allows the loading hopper to be elevated to such a height that the centre line of the chute plate of the hopper when in discharge position, is at an angle of not less than 50° to the horizontal. A mechanical device to aid discharge of the contents as quickly as possible from the hopper to the drum may also be provided. Even when a mechanical device is provided, it is recommended that the angle of centre line of the chute plate

of the hopper when in discharge position, should be as larger as practicable, preferably not less than 40° to horizontal.

(d) When the means of raising and lowering the loading hopper includes flexible wire ropes winding on to a drum or drums, the method of fastening the wire to rope to the drums shall be such as to avoid, as far as possible any tendency to cut the strands of the ropes and the fastening should preferably be positioned clear of the barrel of the drum for example, outside the drums flange When the loading hopper is lowered to its normal loading position, these should be at least one and a half drums of rope on the drum.

(e) Clutch brake and hydraulic control lever shall be designed so as to prevent displacement by liberation or by accidental contact with any person.

(f) The clutch and brake control arrangements shall also be so designed that the operator can control the falling speed of the loader.

(g) Safety device shall be provided to secure the hopper in raised position when not in use.

**4.2.5.2 Mixing Efficiency:** The mixer shall be tested under normal working conditions in accordance with the method specified in IS 4643 with a view to check its ability to mix the ingredients to obtain concrete having uniformity within the prescribed limits. The uniformity of mixed concrete shall be evaluated by finding the percentage variation in quantity (mass in water) of cement, fine aggregate and coarse aggregate in a freshly mixed batch of concrete.

The percentage variation between the quantities of cement, fine aggregate and coarse aggregates(as found by weighing in water) in the two halves of a batch and average of the two halves of the batch shall not be more than the following limits:

Cement 8% Fine aggregate 6% Coarse aggregate 5%

**4.2.5.3 Machine Mixing:** The mixer drum shall be flushed clean with water. Measured quantity of coarse aggregate shall be placed first in the hopper. This shall be followed with measured quantity of fine aggregate and then cement. In case fine aggregate is damp, half the required quantity of coarse aggregate shall be placed in the hopper, followed by fine aggregate and cement. Finally the balance quantity of coarse aggregate shall be fed in the hopper, & then the dry materials are slipped into the drum by raising the hopper. The dry material shall be mixed for at least four turns of the drum. While the drum is rotating, water shall be added gradually to achieve the water cement ratio as specified or as required by the Engineer-in-Charge. After adding water, the mixing shall be continued until concrete of uniform colour, uniformly distributed material and consistency is obtained. Mixing shall be done for atleast two minutes after adding water. If there is segregation after unloading from the mixer, the concrete should be remixed. The drum shall be emptied before recharging. When the mixer is closed down for the day or at any time exceeding 20 minutes, the drum shall be flushed cleaned with water.

**4.2.5.4 Hand Mixing:** When hand mixing has been specifically permitted in exceptional circumstances by the Engineer-in-Charge in writing, subject to adding 10% extra cement, it shall be carried out on a smooth, clean and water tight platform of suitable size. Measured quantity of sand shall be spread evenly on the platform and the cement shall be dumped on the sand and distributed evenly. Sand and cement shall be mixed intimately with spade until mixture is of even colour throughout. Measured quantity of coarse aggregate shall be spread on top of cement sand mixture and mixing done by showlling and turning till the coarse aggregate gets evenly distributed the cement sand mixture. Three quarters of the total quantity of water required shall be added in a hollow made in the middle of the mixed pile and the material is turned towards the middle of pile with spade. The whole mixture is turned slowly over and again and the remaining quantity of water is added gradually. The mixing shall be continued until concrete of uniform colour and consistency is obtained. The mixing platform shall be washed and cleaned at the end of the day.

**4.2.5.5 Transportation and Handling :** Concrete shall be transported from the mixer to the place of laying as rapidly as possible by methods which will prevent the segregation or loss of any of the ingredients and maintaining the required workability. During hot or cold weather, concrete shall be transported in deep containers, other suitable methods to reduce the loss of water by evaporation in hot weather and heat loss in cold weather may also be adopted.

#### **4.2.6 Placing**

The concrete shall be deposited as nearly as practicable in its final position to avoid rehandling. It shall be laid gently (not thrown) and shall be thoroughly vibrated and compacted before setting commences and should not be subsequently disturbed. Method of placing shall be such as to preclude segregation. Care shall be taken to avoid displacement of reinforcement or movement of form work and damage due to rains. As a general guidance, the maximum free fall of concrete may be taken as 1.5 metre.

#### **4.2.7 Compaction**

Concrete shall be thoroughly compacted and fully worked around embedded fixtures and into corners of the form work. Compaction shall be done by mechanical vibrator of appropriate type till a dense concrete is obtained. The mechanical vibrators shall conform to IS 2505, IS 2506, IS 2514 and IS 4656. To prevent segregation, over vibration shall be avoided.

Compaction shall be completed before the initial setting starts. For the items where mechanical vibrators are not to be used, the contractor shall take permission of the Engineer-in-Charge in writing before the start of the work. After compaction the top surface shall be finished even and smooth with wooden trowel before the concrete begins to set.

#### **4.2.8 Construction Joints**

Concreting shall be carried out continuously upto construction joints. The position and arrangement of construction joints shall be as shown in the structural drawings or as directed by the Engineer-in-Charge. Number of such joints shall be kept minimum. Joints shall be kept as straight as possible. Construction joints should comply with IS 11817.

**4.2.8.1** When the work has to be resumed on a surface which has hardened, such surface shall be roughened. It shall then be swept clean and thoroughly wetted. For vertical joints, neat cement slurry, of workable consistency by using 2 kgs of cement per sqm shall be applied on the surface before it is dry. For horizontal joints, the surface shall be covered with a layer of mortar about 10-15 mm thick composed of cement and sand in the same ratio as the cement and sand in concrete mix. This layer of cement slurry of mortar shall be freshly mixed and applied immediately before placing of the concrete.

**4.2.8.2** Where the concrete has not fully hardened, all laitance shall be removed by scrubbing the wet surface with wire or bristle brushes, care being taken to avoid dislodgement of particles of coarse aggregate. The surface shall be thoroughly wetted and all free water removed. The surface shall then be coated with neat cement slurry @ 2 kgs of cement per sqm. On this surface, a layer of concrete not exceeding 150 mm in thickness shall first be placed and shall be well rammed against old work particular attention being paid to corners and close spots; work, thereafter, shall proceed in the normal way.

#### **4.2.10 Curing**

Curing is the process of preventing loss of moisture from the concrete. The following methods shall be employed for effecting curing.

**4.2.10.1 Moist Curing :** Exposed surfaces of concrete shall be kept continuously in a damp or wet condition by ponding or by covering with a layer of sacking, canvas, Hessian or similar materials and kept constantly wet for at least 7 days from the date of placing concrete in case of ordinary Portland cement and at least 10 days where mineral admixtures or blended cements are used. The period of curing shall not be less than 10 days for concrete exposed to dry and hot weather conditions. In the case of concrete where mineral admixtures or blended cements are used, it is recommended that above minimum periods may be extended to 14 days.

**4.2.10.2 Membrane Curing :** Approved curing compounds may be used in lieu of moist curing with the permission of the Engineer-in-Charge. Such compound shall be applied to all exposed surfaces of the concrete as soon as possible after the concrete has set. Impermeable membrane such as polythene sheet covering the concrete surface may also be used to provide effective barrier against the evaporation. **4.2.10.3** Freshly laid concrete shall be protected from rain by suitable covering.

**4.2.10.4** Over the foundation concrete, the masonry work may be started after 48 hours of its compaction but the curing of exposed surfaces of cement concrete shall be continued along with the masonry work for atleast 7 days. And where cement concrete is used as base concrete for flooring, the flooring may be commenced before the curing period of base concrete is over but the curing of base concrete shall be continued along with top layer of flooring for a minimum period of 7 days.

#### **4.2.11 Testing of Concrete**

Testing of concrete shall be done as described in chapter of R.C.C.

#### **4.2.12 Form Work**

Form work shall be as specified in R.C.C. chapter and shall be paid for separately unless otherwise specified.

#### **4.2.13 Finishes**

Plastering and special finishes other than those, obtained through form work shall be specified and paid for separately unless otherwise specified.

#### **4.2.14 Durability of Concrete**

A durable concrete is one that performs satisfactorily in the working environment during its anticipated exposure conditions during service. The materials and mix proportions shall be such as to maintain its integrity and, if applicable, to protect reinforcement from corrosion. The factors influencing durability include.

- (a) The environment;
- (b) The cover to embedded steel;
- (c) The type and quality of constituent materials;

- (d) The cement content and water/ cement ratio of the concrete;
- (e) Workmanship, to obtain full compaction and efficient curing; and
- (f) The shape and size of the member.

#### 4.2.14.1 Requirements for Durability

**4.2.14.1.1 General Environment :** The general environment to which the concrete will be exposed during Its working life is classified into five levels of severity, that is, mild, moderate, severe, very severe and extreme as described in Table 4.9.

**TABLE 4.9**  
**Environmental Exposure Conditions**

<i>Sl. No</i>	<i>Environment</i>	<i>Exposure Conditions</i>
<i>(1)</i>	<i>(2)</i>	<i>(3)</i>
(i)	Mild	Concrete surfaces protected against weather or aggressive conditions, except those situated in coastal area.
(ii)	Moderate	Concrete surfaces sheltered from severe rain or freezing whilst wet Concrete exposed to condensation and rain Concrete continuously under water Concrete in contact or buried under non-aggressive soil/ ground water Concrete surfaces sheltered from saturated salt air in coastal area
(iii)	Severe	Concrete surfaces exposed to severe rain, alternate wetting and drying or occasional freezing whilst wet or severe condensation. Concrete completely immersed in sea water. Concrete exposed to coastal environment.

<i>(1)</i>	<i>(2)</i>	<i>(3)</i>
(iv)	Very severe	Concrete surface exposed to sea water spray, corrosive fumes or severe freezing conditions whilst wet. Concrete in contact with or buried under aggressive sub-soil/ ground water.
(v)	Extreme	Surface of members in tidal zone. Members in direct contact with liquid/ solid aggressive chemicals.

**4.2.14.1.5 Sulphates in Concrete :** The total water-soluble sulphate content of the concrete mix, expressed as SO<sub>3</sub> should not exceed 4 per cent by mass of the cement in the mix. The sulphate content should be calculated as the total from the various constituents of the mix. The 4 per cent limit does not apply to concrete made with supersulphate cement complying with IS 6909.

**TABLE 4.11**  
**Requirements for Concrete Exposed to Sulphate Attack**  
*(Clause 4.2.14.1.3)*

Sl No.	Class	Concentration of sulphates, Expressed as SO <sub>3</sub> Concrete.			Type of Cement	Dense, compacted made with 20 mm nominal maximum size Aggregates complying with IS 383	
		In Soil		In Ground Water (g/l)		Minimum Cement Content kg/m <sup>3</sup>	Maximum Free Water- Cement Ratio
		Total SO <sub>3</sub> (%)	SO <sub>3</sub> in 2:1 (Water: Soil Extract) ( g/l)				
(1)	(2)	(3)	(4)	(5)	(6)	(7)	(8)
(i)	1	Traces (<0.2)	Less than 1.0	Less than 0.3	Ordinary Portland cement or Portland slag cement or Portland - pozzolana cement	280	0.55
(ii)	2	0.2 to 0.5	1.0 to 1.9	0.3 to 1.2	Ordinary Portland cement or Portland slag cement or Portland pozzolana cement	330	0.50
					Supersulphated cement or sulphate resisting Portland cement	310	0.50
(iii)	3	0.5 to 1.0	1.9 to 3.1	1.2 to 2.5	Supersulphated cement or sulphate resisting Portland cement	330	0.50
					Portland Pozzolana cement or Portland slag cement	350	0.45
(iv)	4	1.0 to 2.0	3.1 to 5.0	2.5 to 5.0	Supersulphated or sulphate resisting Portland cement	370	0.45
(v)	5	More than 2.0	More than 5.0	More than 5.0	Sulphate resisting Portland cement or supersulphated cement with protective coatings	400	0.40

#### 4.2.15 Measurements

**4.2.15.1** Dimensions of length, breadth and thickness shall be measured correct to nearest cm. except for the thickness of slab and partition which shall be measured to nearest 5 mm. Areas shall be worked out to nearest 0.01 sqm and the cubic contents of consolidated concrete shall be worked out to nearest 0.01 cum. Any work done in excess over the specified dimension or sections shown in the drawing shall be ignored.

**4.2.15.2** Concrete work executed in the following conditions shall be measured separately:

- (a) Work in or under water
- (b) Work in liquid mud
- (c) Work in or under foul positions

**4.2.15.3 Cast-in-situ concrete** and or precast concrete work shall be measured in stages described in the item of work, such as:

- (a) At or near the ground level
- (b) Upto specified floor level
- (c) Between two specified floor levels
- (d) Upto specified height above or depth below plinth level/ defined datum level.
- (e) Between tow specified heights or depths with reference to plinth/defined datum level.

**4.2.15.4** No deduction shall be made for the following:

- (a) Ends of dissimilar materials for example beams, posts, girders, rafters, purlins, trusses, corbels and steps upto 500 sq cm in cross sections.
- (b) Opening upto 0.1 sq metre (1000 sq.cm)
- (c) Volume occupied by pipes, conduits, sheathing etc. not exceeding 100 sq cm each in cross sectional areas.
- (d) Small voids such as shaded portions in Figure A to J below when these do not exceed 40 sq cm each in cross section.

**Note:** In calculating area of opening, the thickness of any separate lintel or sill shall be included in the height. Nothing extra shall be payable for forming such openings or voids. Area of Fig. A to G shall be =  $L \times B$  Area of Fig. H & J shall be =  $L \times \{ \text{Average of } B \text{ and } B' \}$

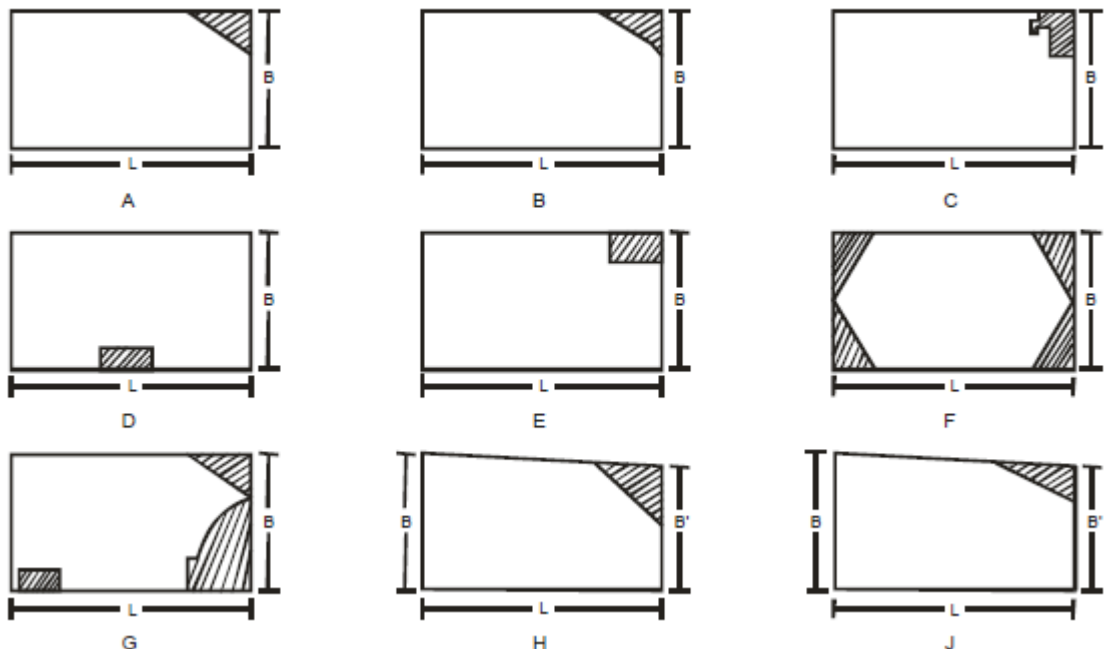



### **4.3 DAMP PROOF COURSE**

#### **4.4.1 Cement Concrete Layer**

This shall consist of cement concrete of specified proportions and thickness. The surface of brick or stone masonry work shall be levelled and prepared before laying the cement concrete. Edge of damp proof course shall be straight, even and vertical. Side shuttering shall consist of steel forms and shall be strong and properly fixed so that it does not get disturbed during compaction and the mortar does not leak through. The concrete mix shall be of workable consistency and shall be tamped thoroughly to make a dense mass. When the sides are removed, the surface should come out smooth without honey coming. Continuity shall be maintained while laying the cement concrete layer and laying shall be terminated only at the predetermined location where damp proof course is to be discontinued. There shall be no construction joints in the Damp Proof Course.

#### **4.4.2 Curing**

Damp proof course shall be cured for at least seven days, after which it shall be allowed to dry.

#### **4.4.3 Application of Hot Bitumen**

Where so directed, hot bitumen in specified quantity shall be applied over the dried up surface of cement concrete, properly cleaned with brushes and finally with a piece of cloth soaked in kerosene oil

Bitumen of penetration A 90 or equivalent where used shall be heated to a temperature of  $160^{\circ} \pm 5^{\circ}\text{C}$ . The hot bitumen shall be applied uniformly all over, so that no blank spaces are left anywhere. It will be paid for separately.

#### **4.4.4 Water Proofing Materials**

Where so specified, water proofing material of approved quality shall be added to the concrete mixture in accordance with the manufacturer's specification stating the quantity of water proofing material in litres or kg per 50 kg of cement and will be paid for separately.

#### **4.4.5 Measurements**

The length and breadth shall be measured correct to a cm and its area shall be calculated in square metres correct to two places of decimal. The depth shall not be less than the specified thickness at any section.

#### **4.4.6 Rate**

The rate is inclusive of the cost of materials and labour involved in all the operations described above except for the applications of a coat of hot bitumen and addition of water proofing materials which shall be paid for separately, unless otherwise specified.

## DETERMINATION OF PARTICLE SIZE

(Clause 4.1.2.3 & 4.1.2.5)

The apparatus, sample size and test procedure shall be same as specified in sub-head 'MORTARS'.

In order that the sieves shall not be overloaded, care must be taken to ensure that the maximum sieve loads shown in Table A-4.1 (below) are not exceeded at the completion of sieving.

TABLE A-4.1

I.S. Sieve Designation	Maximum weight for	
	45 cm dia sieve kg	30 cm dia sieve kg
45 mm	10	4.5
40 mm	8	3.5
31.5 mm or 22.1 mm	6	2.5
20 mm	4	2.0
16 mm or 12.5 mm	3	1.5
10 mm	2	1.0
5.6 mm	1.5	0.75
4.75 mm	1.0	0.50
3.35 mm	-	0.30

## DETERMINATION OF TEN PER CENT FINE VALUE (Clause 4.1.1.5)

**Apparatus:** The apparatus for the standard test shall consist of the following:

- A 15 cm diameter open-ended steel cylinder, with plunger and base-plate, as shown in Fig. in the end of this appendix. The surfaces in contact with the aggregate shall be machined and case hardened or otherwise treated so as to have a diamond (VH) pyramid hardness number of not less than 650 VH.
- A straight metal tamping rod of circular cross-section 16 mm in diameter and 45 to 60 cm long, rounded at one end.
- A balance of capacity 3 Kg, readable and accurate to one gram.
- I.S. Sieve of sizes 12.5, 10 and 2.36 mm.
- A compression testing machine capable of applying a load of 50 tonnes and which can be operate to give a uniform rate of loading so that the maximum load in any test is reached in 10 minutes. This load may vary from 0.5 to 50 tonnes.
- For measuring the sample, a cylindrical metal measure of sufficient rigidity to retain its form under rough usage and of the following internal dimensions:  
Diameter 11.5 cm Height 18.0 cm
- Means of measuring the reduction in the distance between the plates of the testing machine to the nearest one millimetre during the test (for example, dial gauge).

**Test Sample:** Material for the test shall consist of aggregate passing a 12.5 mm I.S. Sieve and retained on a 10 mm I.S. Sieve. The aggregate shall be tested in a surface dry condition. If dries by heating the period of drying shall not exceed four hours, the temperature shall be 100°C to 110°C and the aggregate shall be cooled to room temperature before testing. The quantity of aggregate shall be such that the depth of material in the cylinder, after tamping as described below, shall be 10 cm. The weight of material comprising the test sample shall be determined (weight A) and the same weight of sample shall be taken for the repeat test.

**Note:** About 6.5 kg of natural aggregate is required to provide the two test samoles. Less of light weight aggregate is required. The measuring cylinder is filled in three layers of approximately equal depth with aggregate passing a 12.5 mm I.S. Sieve and retained on 10 mm I.S. Sieve. Each layer is subjected to 25 strokes from the tamping rod (16 mm dia and

45 to 60 cm long) rounded to one end, care being taken in case of weak materials not to break the particles. The surface of the aggregate shall be carefully levelled and the plunger inserted so that it rests horizontally on this surface.

**Test Procedure:** The apparatus, with the test sample and plunger in position, shall then be placed in the compression testing machine. The load shall be applied at a uniform rate so as to cause a total penetration of a plunger in 10 minutes of about: 15.0 mm for rounded or partially rounded aggregates

(for example uncrushed gravel) 20 mm for nominal crushed aggregate & 24 mm for honey combed aggregate (for example expanded shales and slags). These figures may be varied according to the extent of the rounding or honey combing.

After reaching the required maximum penetration, the load shall be released and the whole of the material removed from the cylinder and sieved on a 2.36 mm I.S. Sieve. The fines passing the sieve shall be weighed, and this weight expressed as a percentage of the weight of the test sample. Normally, this percentage will fall within the range 7.5 to 12.5, but if it does not, a further test shall be made at a load adjusted appropriately, to bring the percentage fines within the range of 7.5 to 12.5. A repeat test shall be made at the load that gives as percentage fines within the range 7.5 to 12.5. Calculations: The mean percentage fines from the two tests at this load shall be used in the following formula to calculate the load required to give 10 percentage fines. Load required for 10 percent fines =  $\frac{10000}{Y} \times X$  Where X = Load in tonnes and

Y = mean percentage fines from two test at X tonnes load.

**Reporting of Results:** The load required to produce 10 percent fines shall be reported to the nearest whole number for loads of 10 tonnes or more, the nearest 0.5 tonne for loads of less than 10 tonnes.

The value expressed to the nearest 0.5 tonne should be as follows:

- (a) For normal concrete, not less than 5 tonnes.
- (b) For wearing surfaces, not less than 10 tonnes.
- (c) For granolithic concrete, not less than 15 tonnes.

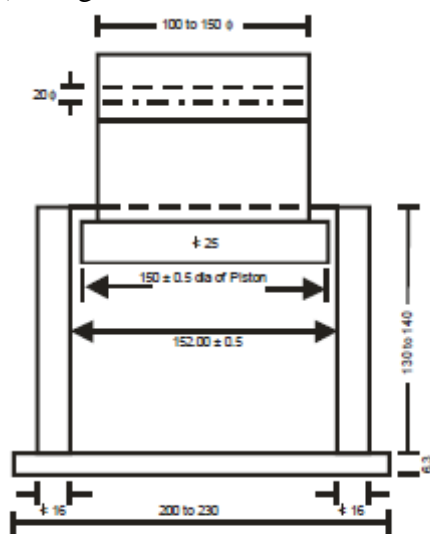

Drawing not to Scale  
All dimensions in millimetres

Internal Diameter of Cylinder =  $152.00 \pm 0.5$

**Fig. C-4.1 : Apparatus for Determination of Ten per cent Fine Value**

**SLUMP TEST**  
**(Clause 4.2.2)**

**Apparatus:** Mould shall consist of a metal frustum of cone having the following internal dimensions:

Bottom diameter.....20 cm

Top diameter.....10 cm

Height.....30 cm

The mould shall be of a metal other than brass and aluminum of at least 1.6 mm (or 16 BG) thickness. The top and bottom shall be open and at right angles to the axis of the cone. The mould shall have a smooth internal surface. It shall be provided with suitable foot pieces and handles to facilitate lifting it from the moulded concrete test specimen in a vertical direction as required by the test. A mould provided with a suitable guide attachment may be used.

Tamping rod shall be of steel or other suitable material 16 mm in diameter 60 mm long and rounded at one end.

**Procedure:** The internal surface of the mould shall be thoroughly cleaned and free from superfluous moisture and any set concrete before commencing the test. The mould shall be placed on a smooth horizontal, rigid and non-absorbent surface viz. levelled metal plate. The operator shall hold the mould firmly in place while it is being filled with test specimen of concrete. The mould shall be filled in four layers, each approximately one quarter of height of mould. Each layer shall be tamped with twenty five strikes of the rounded end of the tamping rod. The strokes shall be distributed in a uniform manner over the cross section of the mould and for the second and subsequent layers shall penetrate into the underlying layer. The bottom layer shall be tamped through out its depth. After the top layer has been rodded, the concrete shall be struck off level with trowel or the tamping rod, so that the mould is exactly filled. Any mortar which shall leak out between the mould and the base plate shall be cleaned away. The mould shall be removed from the concrete immediately after filling by raising it slowly and carefully in a vertical direction. The moulded concrete shall then be allowed to subside and the slump shall be measured immediately by determining the difference between the height of the mould and that of the highest point of specimen. The above operations shall be carried out at a place free from vibration or shock, and within a period of two minutes after sampling.

**Result:** The slump shall be recorded in terms of millimeters of subsidence of the specimen during the test. Any slump specimen which collapses or shears off laterally give incorrect result. If this occurs, the test shall be repeated with another sample. The slump test shall not be used for very dry mixes as the results obtained are not accurate.

**Note:-** For further detail refer CPWD specification volume 1, Sub Head 4.0.

## **SUB HEAD 5.0**

### **REINFORCED CEMENT CONCRETE WORK**

#### **5.0 GENERAL**

Reinforced cement concrete work may be cast-in-situ or Precast as may be directed by Engineer in-charge according to the nature of work. Reinforced cement concrete work shall comprise of the following which may be paid separately or collectively as per the description of the item of work. (a) Form work (Centering and Shuttering)

(b) Reinforcement

(c) Concreting: (1– Cast-in-situ), (2 – Precast)

**Note:** Regarding Mix Design M25:- Due to structural/design requirement, M25 design mix concrete have been taken. It is learnt that due to site condition/remote area the installation of batch mixing plant is very difficult or practically not feasible for obtaining design mix concrete as per standard specification. So it is suggested that the contractor can be obtained M25 grade of concrete by volumetric ratio through mixing of concrete by concrete mixer and vibrator. To achieve the M25 grade concrete the mix design will be obtained by the contractor, from any reputed lab through implementing agency or as per the direction of Engineer Incharge as per available ingredients (Cement, Sand, Aggregate, admixture and Water). According to mix design the contractor will be allowed to carry out the RCC M25 work after converting the design weight of each ingredient mention in mix design into volumetric ratio. The trial sample will be prepared by the contractor before commencement of RCC M25 and after getting satisfactory test report on proposed volumetric ratio, the contractor will be allowed to start the work as per direction of Engineer Incharge.

#### **5.1 MATERIALS**

**5.1.1** Water, cement, fine and coarse aggregate shall be as specified under respective clauses of chapter 03 mortars and chapter 04 concrete work as applicable.

**5.1.2** Fly Ash admixed cement concrete (FACC) and fly ash Blended cements in Cement Concrete (PPCC) in RCC structures.

**5.1.2.0** Fly ash Blended Cements conforming to IS 1489 (Part I) may be used in RCC structures as per guidelines given below :

##### **5.1.2.1 General**

(i) IS 456- 2000 Code of Practice for Plain and Reinforced Concrete (as amended up to date) shall be followed in regard to Concrete Mix Proportion and its production as under :

(a) The concrete mix design shall be done as “Design Mix Concrete” as prescribed in clause-9 of IS 456 mentioned above.

(b) Concrete shall be manufactured in accordance with clause 10 of above mentioned IS 456 covering quality assurance measures both technical and organizational, which shall also necessarily require a qualified Concrete Technologist to be available during manufacture of concrete for certification of quality of concrete.

(ii) Minimum M -25 grade of concrete shall be used in all structural elements made with RCC both in load bearing and framed structure.

(iii) The mechanical properties such as modulus of elasticity, tensile strength, creep and shrinkage of fly ash mixed concrete or concrete using fly ash blended cements (PPCs) are not likely to be significantly different and their values are to be taken same as those used for concrete made with OPC.

(iv) To control higher rate of carbonation in early ages of concrete both in fly ash admixed as well as PPC based concrete, water/binder ratio shall be kept as low as possible, which shall be closely monitored during concrete manufacture.

If necessitated due to low water/binder ratio, required workability shall be achieved by use of chloride free chemical admixtures conforming to IS 9103. The compatibility of chemical admixtures and super plasticizers with each set OPC, fly ash and /or PPC received from different sources shall be ensured by trials.

(v) In environment subjected to aggressive chloride or sulphate attack in particular, use of fly ash admixed or PPC based concrete is recommended. In cases, where structural concrete is exposed to excessive magnesium sulphate, flyash substitution/content shall be limited to 18% by weight Special type of cement with low C3A content may also be alternatively used. Durability criteria like minimum binder content and maximum water /binder ratio also need to be given due consideration in such environment.

(vi) Wet curing period shall be enhanced to a minimum of 10 days or its equivalent. In hot & arid regions, the minimum curing period shall be 14 days or its equivalent.

#### **5.1.2.2 Use of Fly ash Admixed Cement Concrete (FACC) in RCC structures**

There shall be no bar on use of FACC in RCC structures subject to following additional conditions.

(i) Fly ash shall have its chemical characteristics and physical requirements etc. conforming to IS3812 (part I & II) and shall be duly certified.

(ii) To ensure uniform blending of fly ash with cement in conformity with IS 456, a specific facility needs to be created at site with complete computerized automated process control to achieve design quality or with similar facility from Ready Mix Concrete (RMC) plants.

(iii) As per IS 1489 (Part-I) maximum 35% of OPC by mass is permitted to be substituted with fly ash conforming to IS 3812 (Part –I) and same is reiterated.

(iv) Separate storage for dry fly ash shall be provided. Storage bins or silos shall be weather proof and permit a free flow and efficient discharge of fly ash. The filter or dust control system provided in the bins or silos shall be of sufficient size to allow delivery of fly ash maintained at specified pressure to prevent due emission of fly ash dust, which may interfere weighing accuracy.

#### **5.1.2.3 Use of Fly Ash Blended Cements in Cement Concrete (PPCC) in RCC Structures**

(i) Subject to General Guidelines detailed out as above, PPC manufactured conforming to IS 1489(Part-I) shall be treated at par with OPC for manufacture of Design Mix concrete for structural use in RCC.

(ii) Till the time, BIS makes it mandatory to print the %age of fly ash on each bag of cement, the certificate from the PPC manufacture indicating the same shall be insisted upon before allowing use of such cements in works.

(iii) While using PPC for structural concrete work, no further admixing of fly ash shall be permitted.

#### **5.1.3 Steel for Reinforcement**

**5.1.3.1** The steel used for reinforcement shall be any of the following types (**as shown in Structural Drawings**)

(a) Mild steel and medium tensile bars conforming to IS 432 (Part I)

(b) High strength deformed steel bars conforming to IS 1786

(c) Hard drawn steel wire fabric conforming to IS 1566

(d) Structural steel conforming to Grade A of IS 2062

(e) Thermo-mechanically treated (TMT) Bars.

**5.1.3.2** Elongation percent on gauge length is  $5.65 \sqrt{A}$  where A is the cross sectional areas of the test piece.

**5.1.3.3** Mild steel is not recommended for the use in structures located in earthquake zone subjected to severe damage and for structures subjected to dynamic loading (other than wind loading) such as railway and highway bridges.

**5.1.3.4** Welding of reinforcement bars covered in this specification shall be done in accordance with the requirements of IS 2751.

**Nominal mass/weight :** The tolerance on mass/ weight for round and square bars shall be the percentage given in Table 5.1 of the mass/ weight calculated on the basis that the masses of the bar/wire of nominal diameter and of density 7.85 kg/ cm<sup>3</sup> or 0.00785 kg/mm<sup>3</sup>.

**TABLE 5.1**  
**Tolerance on Nominal Mass**

Nominal size in mm	Tolerance on the Nominal Mass per cent		
	Batch	Individual sample +	Individual sample for coil (x)
(a) Upto and including 10	$\pm 7$	-8	$\pm 8$
(b) Over 10, upto and including 16	$\pm 5$	-6	$\pm 6$
(c) Over 16	$\pm 3$	-4	$\pm 4$

+ for individual sample plus tolerance is not specified (x) for coil batch tolerance is not applicable

Tolerance shall be determined in accordance with method given in IS 1786.

**5.1.3.5** High strength deformed bars & wires shall conform to IS 1786. The physical properties for all sizes of steel bars are mentioned below in Table 5.2.

**TABLE 5.2**

Sl. No	Property	Fe 415	Fe 415 D	Fe 500 D	Fe 550 D
(i)	0.2 Per cent Proof stress/ yield stress, Min, N/mm <sup>2</sup>	415.0	415.0	500.0	550.0
(ii)	Elongation, per cent, Min. on gauge length $5.65 \sqrt{A}$ , where A is the corss-sectional area of the test piece.	14.5	18.0	16.0	14.5
(iii)	Tensile strength, Min	10 Per cent more than the actual 0.2 per cent proof stress/ yield stress but not less than 485.0 N/mm <sup>2</sup>	12 Per cent more than the actual 0.2 per cent proof stress/ yield stress but not less than 500.0 N/mm <sup>2</sup>	10 Per cent more than the actual 0.2 per cent proof stress/ yield stress but not less than 565.0 N/mm <sup>2</sup>	8 Per cent more than the actual 0.2 per cent proof stress/ yield stress but not less than 600.0 N/mm <sup>2</sup>
(iv)	Total elongation at maximum force, percent, Min on gauge length $5.65 \sqrt{A}$ , where A is the cross-sectional area of the test piece.	-	5	5	5

**5.1.3.6** Chemical composition of reinforcement bars shall be as per Table 5.3 as follows:-

**TABLE 5.3**

<i>Constituent</i>	<i>Maximum Per cent</i>			
	<i>Fe 415</i>	<i>Fe 415 D</i>	<i>Fe 500 D</i>	<i>Fe 550 D</i>
Carbon	0.30	0.25	0.25	0.25
Sulphur	0.060	0.045	0.040	0.040
Phosphorus	0.060	0.045	0.040	0.040
Sulphur and Phosphorus	0.110	0.085	0.075	0.075

**5.1.3.7** Thermo Mechanically treated reinforcement bars:

(a) There is no BIS code for TMT bars. The available code BIS 1786 pertains to HSD Bars. Therefore there should be no stipulation that TMT bars should conform to relevant BIS code.

(b) The TMT bars are being produced under valid licence from either of the firms namely Tempcore Thermex Evcon Turbo & Turbo Quench. These firms have acquired patents and are giving licences to various producers to produce TMT Bars.

(c) The TMT bars shall conform to IS 1786 pertaining to Fe 415 D or Fe 500 D or Fe grade of steel as specified.

(d) In design and construction of reinforced concrete building in seismic zone III and above, steel reinforcement of Grade Fe 415 D shall be used. However, high strength deformed steel bars, produced by thermo mechanical treatment process of grade Fe 415, Fe 500 and Fe 550 having elongation more than 14.5. % and conform to other requirements of Fe 415 D, Fe 500 D and Fe550 D respectively of IS 1786 may also be used for reinforcement. In future, latest provision of IS 456 and IS 13920 or any other relevant code as modified from time to time shall be applicable.

## **5.2 FORM WORK (CENTRING & SHUTTERING)**

### **5.2.1 Form Work**

Form work shall include all temporary or permanent forms or moulds required for forming the concrete which is cast-in-situ, together with all temporary construction required for their support.

### **5.2.2 Design & Tolerance in Construction**

Form work shall be designed and constructed to the shapes, lines and dimensions shown on the drawings with the tolerance given below.

(a) Deviation from specified dimension of cross +12 mm section of columns and beams -6 mm

(b) Deviation from dimensions of footings

(i) Dimension in Plan (+ 50 mm ( -12 mm

(ii) Eccentricity in plan 0.02 times the width of the footing in the direction of deviation but not more than 50 mm.

(iii) Thickness + 0.05 times the specified thickness.

**(Note-** These tolerance apply to concrete dimensions only, and not to positioning of vertical steel or dowels).

### **5.2.3 General Requirement**

It shall be strong enough to withstand the dead and live loads and forces caused by ramming and vibrations of concrete and other incidental loads, imposed upon it during and after casting of concrete. It shall be made sufficiently rigid by using adequate number of ties and braces, screw jacks or hard board wedges where required shall be provided to make up any settlement in the form work either before or during the placing of concrete. Form shall be so constructed as to be removable in sections in the desired sequence, without damaging the surface of concrete or disturbing other sections, care shall be taken to see that no piece is keyed into the concrete.



### **5.2.3.1 Material for Form Work**

(a) Propping and Centering : All propping and centering should be either of steel tubes with extension pieces or built up sections of rolled steel.

**5.2.3.2 (a) Centering/Staging :** Staging should be as designed with required extension pieces as approved by Engineer-in-Charge to ensure proper slopes, as per design for slabs/ beams etc. and as per levels as shown in drawing. All the staging to be either of Tubular steel structure with adequate bracings as approved or made of built up structural sections made form rolled structural steel sections

(b) In case of structures with two or more floors, the weight of concrete, centering and shuttering of any upper floor being cast shall be suitably supported on one floor below the top most floor already cast.

(c) Form work and concreting of upper floor shall not be done until concrete of lower floor has set at least for 14 days.

**5.2.3.3 Shuttering:** Shuttering used shall be of sufficient stiffness to avoid excessive deflection and joints shall be tightly butted to avoid leakage of slurry. If required, rubberized lining of material as

approved by the Engineer-in-Charge shall be provided in the joints. Steel shuttering used or concreting should be sufficiently stiffened. The steel shuttering should also be properly repaired before use and properly cleaned to avoid stains, honey combing, seepage of slurry through joints etc.(a) Runner Joists: RSJ, MS Channel or any other suitable section of the required size shall be used as runners.

(b) Assembly of beam head over props. Beam head is an adopter that fits snugly on the head plates of props to provide wider support under beam bottoms.

(c) Only steel shuttering shall be used, except for unavoidable portions and very small works for which 12 mm thick water proofing ply of approved quality may be used.

**5.2.3.4** Form work shall be properly designed for self weight, weight of reinforcement, weight of fresh concrete, and in addition, the various live loads likely to be imposed during the construction process(such as workmen, materials and equipment). In case the height of centering exceeds 3.50 metres, the prop may be provided in multi-stages. A typical detail of multistage shuttering is given in Fig. 5.9.

**5.2.3.5 Camber:** Suitable camber shall be provided in horizontal members of structure, especially in cantilever spans to counteract the effect of deflection. The form work shall be so assembled as to provide for camber. The camber for beams and slabs shall be 4 mm per metre (1 to 250 ) or as directed by the Engineer-in-Charge, so as to offset the subsequent deflection, For cantilevers the camber at free end shall be 1/50th of the projected length or as directed by the Engineer-in-Charge.

**5.2.3.5.1** Typical arrangement of form work for 'beams, columns and walls' are shown in Figures 5.1 to

5.8 and form secured by wall ties is shown in Fig. 5.3.

**5.2.3.6 Walls :** The form faces have to be kept at fixed distance apart and an arrangement of wall ties with spacer tubes or bolts is considered best. A typical wall form with the components identified is given in Fig. 5.1, 5.2 & 5.3. The two shutters of the wall are to be kept in place by appropriate ties, braces and studs, some of the accessories used for wall form are shown in Fig. 5.3.

**5.2.3.7 Removal of Form work (Stripping Time) :** In normal circumstance and where various types of cements are used, forms, may generally be removed after the expiry of the following periods:

Type of Form work	Minimum period Before Striking Form work for OPC 33 grade	Minimum period Before Striking Form work for OPC 43 grade	Minimum period Before Striking Form work for PPC
(a) Vertical form work to columns, walls, beams	16-24 h	16-24 h	24-36 h

Type of Form work	Minimum period Before Striking Form work for OPC 33 grade	Minimum period Before Striking Form work for OPC 43 grade	Minimum period Before Striking Form work for PPC
(b) Soffit form work to slabs (Props to be refixed immediately after removal of formwork)	3 days	3 days	4 days
(c) Soffit form work to beams (Props to be refixed immediately after removal of formwork)	7 days	7 days	10 days
(d) Props to slabs: (1) Spanning upto 4.5m (2) Spanning over 4.5m	7 days 14 days	7 days 14 days	10 days 20 days
(e) Props to beams and arches: (1) Spanning upto 6m (2) Spanning over 6m	14 days 21 days	14 days 21 days	20 days 30 days

## 5.2.4 Surface Treatment

**5.2.4.1 Oiling the Surface :** Shuttering gives much longer service life if the surfaces are coated with suitable mould oil which acts both as a parting agent and also gives surface protections. A typical mould oil is heavy mineral oil or purified cylinder oil containing not less than 5% pentachlorophenol conforming to IS 716 well mixed to a viscosity of 70-80 centipoises. After 3-4 uses and also in cases when shuttering has been stored for a long time, it should be recoated with mould oil before the next use.

## 5.2.5 Inspection of Form Work

The completed form work shall be inspected and approved by the Engineer-in-Charge before the reinforcement bars are placed in position. Proper form work should be adopted for concreting so as to avoid honey combing, blow holes, grout loss, stains or discoloration of concrete etc. Proper and accurate alignment and profile of finished concrete surface will be ensured by proper designing and erection of form work which will be approved by Engineer-in-Charge. Shuttering surface before concreting should be free from any defect/deposits and full cleaned so as to give perfectly straight smooth concrete surface. Shuttering surface should be therefore checked for any damage to its surface and excessive roughness before use.

**5.2.5.1 Erection of Form Work (Centering and shuttering):** Following points shall be borne in mind while checking during erection.

- (a) Any member which is to remain in position after the general dismantling is done, should be clearly marked.
- (b) Material used should be checked to ensure that, wrong items/ rejects are not used. (c) If there are any excavations nearby which may influence the safety of form works, corrective and strengthening action must be taken.
- (d) (i) The bearing soil must be sound and well prepared and the sole plates shall bear well on the ground.  
(ii) Sole plates shall be properly seated on their bearing pads or sleepers  
(iii) The bearing plates of steel props shall not be distorted.  
(iv) The steel parts on the bearing members shall have adequate bearing areas.
- (e) Safety measures to prevent impact of traffic, scour due to water etc. should be taken. Adequate precautionary measures shall be taken to prevent accidental impacts etc.

(f) Bracing, struts and ties shall be installed along with the progress of form work to ensure strength and stability of form work at intermediate stage. Steel sections (especially deep sections) shall be adequately restrained against tilting, overturning and form work should be restrained against horizontal loads. All the securing devices and bracing shall be tightened.

## **5.2.6 Measurements**

**5.2.6.1 General :** The form work shall include the following:

- (a) Splayed edges, notching, allowance for overlaps and passing at angles, sheathing battens, strutting, bolting, nailing, wedging, easing, striking and removal.
- (b) All supports, struts, braces, wedges as well as mud sills, piles or other suitable arrangements to support the form work.
- (c) Bolts, wire, ties, clamps, spreaders, nails or any other items to hold the sheathing together.
- (d) Working scaffolds, ladders, gangways, and similar items.
- (e) Filletting to form stop chamfered edges of splayed external angles not exceeding 20mm wide to beams, columns and the like.
- (f) Where required, the temporary openings provided in the forms for pouring concrete, inserting vibrators, and cleaning holes for removing rubbish from the interior of the sheathing before pouring concrete.
- (g) Dressing with oil to prevent adhesion and
- (h) Raking or circular cutting

**5.2.6.2 Classification of Measurements :** Where it is stipulated that the form work shall be paid for separately, measurements shall be taken of the area of shuttering in contact with the concrete surface. Dimensions of the form work shall be measured correct to a cm. The measurements shall be taken separately for the following.

- (a) Foundations, footings, bases of columns etc. and for mass concrete
- (b) Walls (any thickness) including attached pilasters, buttresses, plinth and string courses etc.
- (c) Suspended floors, roofs, landings, shelves and their supports and balconies.
- (d) Lintels, beams, plinth beams, girders, bresssummers and cantilevers.
- (e) Columns, pillars, piers, abutments posts and struts.
- (f) Stairs (excluding landings) except spiral staircase.
- (g) Spiral staircases (including landings).
- (h) Arches, Domes, vaults, shells roofs, arch ribs, curvilinear shaped folded plates
- (i) Extra for arches, domes, vaults exceeding 6 m span other than curvilinear shaped
- (j) Chimneys and shafts.
- (k) Well steining.
- (l) Vertical and horizontal fins individually or forming box, louvers and bands. facias and eaves board
- (m) Waffle or ribbed slabs.
- (n) Edges of slabs and breaks in floors and walls (to be measured in running metres where below 200 mm in width or thickness).
- (o) Cornices and mouldings.
- (p) Small surfaces, such as cantilevers ends, brackets and ends of steps, caps and boxes to pilasters and columns and the like.
- (q) Chullah hoods, weather shades, chajjas, corbels etc. including edges and
- (r) Elevated water reservoirs.

## 5.3 REINFORCEMENTS

### 5.3.1 General Requirements

Steel conforming to para 5.1.3 for reinforcement shall be clear and free from loose mill scales, dust, loose rust, coats of paints, oil or other coating which may destroy or reduce bond. It shall be stored in such a way as to avoid distortion and to prevent deterioration and corrosion. Prior to assembly of reinforcement on no account any oily substance shall be used for removing the rust.

**5.3.1.1 Assembly of Reinforcement :** Bars shall be bent correctly and accurately to the size and shape as shown in the detailed drawing or as directed by Engineer-in-Charge. Preferably bars of full length shall be used. Necessary cutting and straightening is also included. Overlapping of bars, where necessary shall be done as directed by the Engineer-in-Charge. The overlapping bars shall not touch each other and these shall be kept apart with concrete between them by 25mm or 1/4 times the maximum size of the coarse aggregate whichever is greater. But where this is not possible, the overlapping bars shall be bound together at intervals not exceeding twice the dia. of such bars with two strands annealed steel wire of 0.90 mm to 1.6 mm twisted tight. The overlaps/ splices shall be staggered as per directions of the Engineer-in-Charge. But in no case the overlapping shall be provided in more than 50% of cross sectional area at one section.

**5.3.1.2 Bonds and Hooks Forming End Anchorages:** Reinforcement shall be bent and fixed in accordance with procedure specified in IS 2502, code of practice of bending and fixing of bars for concrete reinforcement. The details of bends and hooks are shown below for guidance.

(a) U-Type Hook

In case of mild steel plain bars standard U type hook shall be provided by bending ends of rod into semicircular hooks having clear diameter equal to four times the diameter of the bar.

**Note:** In case of work in seismic zone, the size of hooks at the end of the rod shall be eight times the diameter of bar or as given in the structural drawings.

(b) Bends

Bend forming anchorage to a M.S. plain bar shall be bent with an internal radius equal to two times the diameter of the bar with a minimum length beyond the bend equal to four times the diameter of the bar.

**5.3.1.3 Anchoring Bars in Tension :** Deformed bars may be used without end anchorages provided, development length requirement is satisfied. Hooks should normally be provided for plain bars in tension. Development length of bars will be determined as per IS: 456.

**5.3.1.4 Anchoring Bars in Compression :** The anchorage length of straight bar in compression shall be equal to the 'Development length' of bars in compression as specified in IS: 456. The projected length of hooks, bend and straight lengths beyond bend, if provided for a bar in compression, shall be considered for development length.

**5.3.1.5 Binders, stirrups, links etc. :** In case of binders, stirrups, links etc. the straight portion beyond the curve at the end shall be not less than eight times and nominal size of bar.

### 5.3.2 Welding of Bars

Wherever facility for electric arc welding or gas pressure welding is available, welding of bars shall be done in lieu of overlap. The location and type of welding shall be got approved by the Engineer-in-Charge. Welding shall be as per IS 2751 and 9417.

### 5.3.3 Placing in Position

**5.3.3.1** Fabricated reinforcement bars shall be placed in position as shown in the drawings or as directed by the Engineer-in-charge. The bars crossing one another shall be tied together at every intersection with two strands of annealed steel wire 0.9 to 1.6 mm thickness twisted tight to make the skeleton of the steel work rigid so that the reinforcement does not get displaced during deposition of concrete.

**5.3.3.5 Cover :** The minimum nominal cover to meet durability requirements shall be as under:-

<i>Exposure</i>	<i>Nominal Concrete cover in mm not less than</i>
Mild	20
Moderate	30
Severe	45
Very severe	50
Extreme	75

- Notes :**
1. For main reinforcement upto 12 mm diameter bar for mild exposure the nominal cover may be reduced by 5 mm.
  2. Unless specified otherwise, actual concrete cover should not deviate from the required nominal cover by + 10 mm.
  3. For exposure condition 'severe' and 'very severe' reduction of 5 mm may be made, where concrete grade is M35 and above.
  4. Nominal cover to meet specified period of fire resistance shall not be less than as given in Table 16A of IS 456.

### 5.3.4 Measurement

Reinforcement including authorized spacer bars and lappages shall be measured in length of different diameter, as actually (not more than as specified in the drgs.) used in the work nearest to a centimeter and their weight calculated on the basis of standard weight given in Table 5.4 below. In case actual unit weight of the bars is less than standard unit weight, but within variation, in such cases weight of reinforcement shall be calculated on the basis of actual unit weight. Wastage and unauthorized overlaps shall not be paid for. Annealed steel wire required for binding or tack welding shall not be measured, its cost being included in the rate of reinforcement. Where tack welding is used in lieu of binding, such welds shall not be measured. Chairs separators etc. shall be provided as directed by the Engineer-in-Charge and measured separately and paid for.

**TABLE 5.4**  
**Cross Sections Area and Mass of Steel Bar**

<i>Nominal Size mm</i>	<i>Cross sectional Area Sq.mm</i>	<i>Mass per metre Run Kg.</i>
6	28.3	0.222
8	50.3	0.395
10	78.6	0.617
12	113.1	0.888
16	201.2	1.58
20	314.3	2.47
25	491.1	3.85
28	615.8	4.83
32	804.6	6.31
36	1018.3	7.99
40	1257.2	9.86

**Note:** These are as per clause 6.2 of IS 1786.

### 5.4.3 Compaction

It shall be as specified in sub-head of Concrete Work of this specification.

**5.4.3.1** Concrete shall be compacted into dense mass immediately after placing by means of mechanical vibrators designed for continuous operations complying with IS 2505, IS 2506, IS 2514 and IS 4656. The Engineer-in-Charge may however relax this condition at his discretion for certain items depending on the thickness of the members and feasibility of vibrating the same and permit hand compaction instead. Hand compaction shall be done with the help of tamping rods so that concrete is thoroughly compacted and completely worked around the reinforcement, embedded fixtures, and into corners of the form. The layers of concrete shall be so placed that the bottom layer does not finally set before the top layer is placed. The vibrators shall maintain the whole of concrete under treatment in an adequate state of agitation; such that de-aeration and effective compaction is attained at a rate commensurate with the supply of concrete from the mixers. The vibration shall continue during the whole period occupied by placing of concrete, the vibrators being adjusted so that the centre of vibrations approximates to the centre of the mass being compacted at the time of placing.

**5.4.3.2** Concrete shall be judged to be properly compacted, when the mortar fills the spaces between the coarse aggregate and begins to cream up to form an even surface. When this condition has been attained, the vibrator shall be stopped in case of vibrating tables and external vibrators. Needle vibrators shall be withdrawn slowly so as to prevent formation of loose pockets in case of internal vibration. In case both internal and external vibrators are being used, the internal vibrator shall be first withdrawn slowly after which the external vibrators shall be stopped so that no loose pocket is left in the body of the concrete. The specific instructions of the makers of the particular type of vibrator used shall be strictly complied with. Shaking of reinforcement for the purpose of compaction should be avoided. Compaction shall be completed before the initial setting starts, i.e. with 30 minutes of addition of water to the dry mixture.

#### **5.4.5 Expansion Joints**

Expansion joints shall be provided as shown in the structural drawings or as indicated in Fig. 5.10 to 5.25 or as directed by Engineer-in-Charge, for the purpose of general guidance. However it is recommended that structures exceeding 45 m in length shall be divided by one or more expansion joints. The filling of these joints with bitumen filler, bitumen felt or any such material and provision of copper plate, etc. shall be paid for separately in running metre. The measurement shall be taken two places of decimal stating the depth and width of joint.

#### **5.4.6 Curing**

After the concrete has begun to harden i.e. about 1 to 2 hours after its laying, it shall be protected from quick drying by covering with moist gunny bags, sand, canvass Hessian or any other material approved by the Engineer-in-Charge. After 24 hours of laying of concrete, the surface shall be cured by ponding with water for a minimum period of 7 days from the date of placing of concrete in case of OPC and at least 10 days where mineral admixtures or blended cements are used. The period of curing shall not be less than 10 days for concrete exposed to dry and hot weather condition.

#### **5.4.7 Finishing**

**5.4.7.1** In case of roof slabs the top surface shall be finished even and smooth with wooden trowel, before the concrete begins to set. **Sprinkling of dry cement while finishing shall not be resorted to.**

**5.4.7.2** Immediately on removal of forms, the R.C.C. work shall be examined by the Engineer-in-Charge, before any defects are made good.

(a) The work that has sagged or contains honey combing to an extent detrimental to structural safety or architectural concept shall be rejected as given in para 5.4.9.4 for visual inspection test. (b) Surface defects of minor nature may be accepted. On acceptance of such a work by the Engineer-in-Charge, the same shall be rectified as follows:

1. Surface defects which require repair when forms are removed, usually consist of bulged due to movement of forms, ridges at form joints, honey-combed areas, damage resulting from the stripping of forms and bolt holes, bulges and ridges are removed by careful chipping or tooling and the surface is then rubbed with a grinding stone. Honey-combed and other defective areas must be chipped out, the edges being cut as straight as possible and perpendicularly to the surface, or preferably slightly under cut to provide a key at the edge of the patch.

2. Shallow patches are first treated with a coat of thin grout composed of one part of cement and one part of fine sand and then filled with mortar similar to that used in the concrete. The mortar is placed in layers not more than 10mm thick and each layer is given a scratch finish to secure bond with the succeeding layer. The last layer is finished to match the surrounding concrete by floating, rubbing or tooling on formed surfaces by pressing the form material against the patch while the mortar is still plastic.

3. Large and deep patches require filling up with concrete held in place by forms. Such patches are reinforced and carefully dowelled to the hardened concrete.

4. Holes left by bolts are filled with mortar carefully packed into places in small amounts. The mortar is mixed as dry as possible, with just enough water so that it will be tightly compacted when forced into place.

5. Tiered holes extending right through the concrete may be filled with mortar with a pressure gun similar to the gun used for greasing motor cars.

6. Normally, patches appear darker than the surrounding concrete, possibly owing to the presence on their surface of less cement laitance. Where uniform surface colour is important, this defect shall be remedied by adding 10 to 20 percent of white Portland cement to the patching mortar, the exact quantity being determined by trial.

7. The same amount of care to cure the materials in the patches should be taken as with the whole structure. Curing must be started as soon as possible, after the patch is finished to prevent early drying. Damp Hessian may be used but in some locations it may be difficult to hold it in place. A membrane curing compound in these cases will be most convenient.

#### **5.4.9 Testing of Concrete**

**5.4.9.0** Regular mandatory tests on the workability of the fresh concrete shall be done to achieve the

specified compressive strength of concrete. These will be of two types

(a) Mandatory Lab, Test

(b) Mandatory Field Test

Results of Mandatory Field Test will prevail over mandatory Lab. Test.

**5.4.9.1 Cube Test for Compressive Strength of Concrete - Mandatory Lab Test :** Mandatory tests shall be carried out as prescribed in Appendix A of Chapter 5.

**5.4.9.2 Additional Test :** Additional test, if required, shall be carried out as prescribed in Appendix B of Chapter 5.

**5.4.9.3 Slump Test :** This test shall be carried out as prescribed in sub-head 4 of concrete.

**5.4.9.4 Visual Inspection Test :** The concrete will be inspected after removal of the form work as described in para 5.4.7.2 The question of carrying out mandatory test or other tests

described in Appendix A and B (para 5.4.9.1 and 5.4.9.2) will arise only after satisfactory report of visual inspection. The concrete is liable to be rejected if:

- (i) It is porous or honeycombed as per para 5.4.7.2 (a).
- (ii) Its placing has been interrupted without providing a proper construction joint.
- (iii) The reinforcement has been displaced beyond tolerance specified or construction tolerances have not been met. However, the hardened concrete may be accepted after carrying out suitable remedial measures to the satisfaction of the Engineer-in-Charge at the risk and cost of the contractor.

#### **5.4.10 Standard of Acceptance – for Nominal Mix**

**5.4.10.1 Mandatory Lab. Test :** For concrete sampled and tested as prescribed in Appendix A of Chapter 5, the following requirement shall apply.

**5.4.10.2** Out of six sample cubes, three cubes shall be tested at 7 days and remaining three cubes at 28days.

#### **5.4.10.3 7 days' Tests**

**Sampling:** The average of the strength of three specimen shall be accepted as the compressive strength of the concrete provided the variation in strength of individual specimen is not more than + 15% of the average. Difference between the maximum and minimum strength should not exceed 30% of average strength of three specimen. If the difference between maximum and minimum strength exceeds 30% of the average strength, then 28 days' test shall have to be carried out.

**Strength:** If the actual average strength of sample accepted in para 'sampling' above is equal to or higher than specified strength upto +15% then strength of the concrete shall be considered in order. In case the actual average strength of sample accepted in the above para is lower than the specified or higher by more than 15% then 28 days' test shall have to be carried out to determine the compressive strength of concrete cubes.

#### **5.4.10.4 28 days' Test**

(a) The average of the strength of three specimen be accepted as the compressive strength of the concrete provided the strength of any individual cube shall neither be less than 70% nor higher than 130% of the specified strength.

(b) If the actual average strength of accepted sample exceeds specified strength by more than 30% the Engineer-in-Charge, if he so desires, may further investigate the matter. However, if the strength of any individual cube exceeds more than 30% of specified strength, it will be restricted to 130% only for computation of strength.

(c) If the actual average strength of accepted sample is equal to or higher than specified strength upto 30% then strength of the concrete shall be considered in order and the concrete shall be accepted at full rates.

(d) If the actual average strength of accepted sample is less than specified strength but not less than 70% of the specified strength, the concrete may be accepted at reduced rate at the discretion of Engineer-in-Charge

(e) If the actual average strength of accepted sample is less than 70% of specified strength, the Engineer-in-Charge shall reject the defective portion of work represented by sample and nothing shall be paid for the rejected work. Remedial measures necessary to retain the structure shall be taken at the risk and cost of contractor. If, however the Engineer-in-Charge so desires, he may order additional tests (See Appendix B of Chapter 5) to be carried out to ascertain if the structure can be retained. All the charges in connection with these additional tests shall be borne by the contractor.

#### **5.4.10.5 Acceptance Criteria of Field Test (Additional Test – Not Mandatory)**



**(A) Preparation of Standard Test Cubes for calibration of Rebound Hammer at site**

(a) In the beginning the standard test cubes of the specified mix shall be prepared by field units before undertaking any concrete work in each project.

(b) At least 18 standard cubes necessary for formation of one specimen of specified mix, shall be cast by site staff well in advance. From these 18 cubes any 3 cubes may be selected at random to be tested for crushing strength of 7 days. The crushing strength obtained should satisfy the specified strength for the mix as per specification or agreement. If the strength is satisfactory then the remaining cube will form the standard samples for calibration of rebound

hammer. In case of failure, the site staff should totally reject the samples and remove them also and then make another set of samples by fresh mixing or alternatively, out of the remaining 15 cubes, 3 cubes will be tested on 28 days. If the 28 days' tests are found satisfactory then remaining 12 cubes will form the standard sample for calibration at 28 days' strength otherwise all samples shall be rejected and whole procedure repeated to form a fresh specimen. All the results shall be recorded in a register. (c) No concreting will be allowed unless the standard specimen cubes are obtained. The criteria for acceptance and calibration of hammer will be 28 days' strength. The 7 days' strength is only to facilitate the work to start.

(d) No work (for the concrete cast between 8th and 28th day) shall be allowed to be paid unless 28 days' cube strength is obtained. For the concrete cast between 8th and 28th day, the decision to make the payment may be taken by the Engineer-in-charge on the basis of existing criteria. Concrete work will be rejected if 28 days' strength falls short as per acceptance criteria. No further work will be allowed till the acceptable standard cubes are obtained.

(e) Frequency: it will be once in each quarter or as per the direction and discretion of Engineer-in- Charge. Whenever the acceptance criteria is changed or concrete mix or type of cement is changed or Engineer-in-Charge feels it necessary for recorded reasons with the approval of the authority according to technical sanction, fresh specimen shall be prepared.

**(B) Calibration of Hammer**

(a) Simultaneously, same three cubes to be tested on 28 days as referred in para A (b) above shall be used to correlate the compressive strength of their concrete with rebound number as per procedure described in para 5.2 of the IS 13311 (Part 2) "Indian standard for nondestructive testing of concrete Method of test by rebound hammer which is given below in para B (b). The average of values of the rebound number (minimum readings) obtained in respect of same three cubes passing on 28 days' work test shall form the datum reference for remaining cubes for the strength of cubes

(b) The concrete cubes specimens are held in a compression testing machine under a fixed load, measurements of rebound hammer taken and then compressive strength determined as per IS 516. The fixed load required is of the order of 7 N/mm<sup>2</sup> when the impact energy of the hammer is about 2.2 NM. If the specimen are wet cured, they should be removed from wet storage & kept in the laboratory atmosphere for about 24 hours before testing. Only the vertical faces of the cubes as cast should be tested for rebound number. At least nine readings should be taken on each of the three vertical faces accessible in the compression testing machine when using rebound hammers. The points of impact in the specimen must not be nearer than 20 mm from the edge & should not be

(c) The rebound number of hammer will be determined on each of the remaining (18-3-3=12) cubes. Whenever the rebound number of hammer of any individual cube varies by more than +25% from the datum readings referred to in para B (a) above, that cube will be excluded and will not be considered for standard specimen cubes for calibration. It must be ensured that at least 8 cubes out of 12 that is 66.67% are within the permissible range of variation of rebound number i.e. +25% or otherwise whole procedure shall have to be repeated and fresh specimen prepared. These 8 cubes will form one standard sample in the

beginning before commencement of work and shall be kept carefully for the visiting officers who will calibrate their hammers on these cubes. (d) This calibration will be done by field staff with their hammer and then chart of calibration giving the details of the average readings, date & month of casting, mix of the concrete etc. shall be prepared and signed by Engineer-in-Charge and will be duly preserved for future reference as and when required.

**(C) Preservation of Cubes at site**

Standard sample cubes cast shall be carefully preserved at site under the safe custody of AE or his representative for making them available together with the charts, to the officers of QCTA/CTE or any other senior departmental officer, during their inspection of the work. They will calibrate their hammer on these cubes if required.

**(D) Testing at Site**

**(D-1) Testing Equipments**

(D-2) Testing will be done generally by non-destructive methods like rebound hammers etc. Each field Division/ Sub Division/ Unit will purchase rebound hammers and keep them in working order at work site. The testing will be done only by hammers which are duly calibrated. (D-3) The relative strength of actual field work will be tested with reference to strength of these standard cubes and calibration charts of a hammer for determining the rebound number on the field work. The hammer will be used as per manufacturer's guidelines at various locations chosen at random. The number of location/reading on each wall, beam or column etc. shall not be less than 12. All the readings should be within the +25% range of values prescribed in calibration chart normally. However, reading indicating good strength will be when it is at par with calibrated value or between 100% & 125% and very good if more than 125% any value between 100% & 75% of calibrated value shall be considered satisfactory. Values from 75% to 50% shall be considered for payment at rates reduced on prorata basis. The concrete indicating rebound number less than 50% of calibrated value shall be rejected and not paid for.

**(E) Acceptance of Field Tests and Strength**

If the relative strength of actual field work is found satisfactory considering the calibration charts with reference to the standard cube test kept at site, the representative work will be considered satisfactory. If the work is considered below satisfactory, the same will be dealt as stated in para D-3 above. (F) 7 days' Strength in Rare Cases only

Normally cube crushing strength on 28 days' test shall form the basis of acceptance. However in rare cases of time bound projects/ urgent repairs 7 days' cube test strength criteria may be adopted on similar lines using 7 days' standard test cubes and calibration graphs/ curves/ charts for 7 days' in lieu of 28 days' and testing work done at 7 days'.

**(G) Precautions**

(G-1) The testing shall be done generally as per guidelines of manufacture of the apparatus and strictly in accordance with the procedure laid down in clause 6 of IS 13311 (Part 2): Indian Standard for Non-Destructive Testing of Concrete - Method of Test by Rebound Hammer.

(G-2) The rebound hammers are influenced by number of factor like type of cement aggregate, surface conditions, moisture content, age of concrete & extent of calibration of concrete etc. hence care shall be taken to compare the cement, aggregate etc. and tested under the similar surface conditions having more or less same moisture content and age. However effect of age can be ignored for concrete between 3 days & 3 months old.

### **5.4.11 Measurements**

**5.4.11.1** Dimensions shall be measured nearest to a cm except for the thickness of slab which shall be measured correct to 0.5 cm. The areas shall be worked out nearest to 0.01 Sq. mt. The cubical contents shall be worked out to nearest 0.01 cubic metre.

**5.4.11.2** Reinforced cement concrete whether cast-in-situ or pre cast shall be classified and measured separately as follows.

- (a) Raft, footing, bases of columns and mass concrete etc. all work up to plinth level, column up to plinth level, plinth beams.
- (b) Wall (any thickness) including attached pilasters, buttresses plinth and string course, fillets, column, pillars, piers, abutments, post and struts etc.
- (c) Suspended floors, roofs, landings and balconies.
- (d) Shelves
- (e) Chajjas
- (f) Lintel, beams and bressummers.
- (g) Columns, pillars, piers, abutments, posts and struts.
- (h) Stair-cases including waist or waist less slab but excluding landing except in (i) below.
- (i) Spiral stair-case (including landing).
- (j) Arches, arch ribs, domes and vaults.
- (k) Chimneys and shafts.
- (l) Well steining.
- (m) Vertical and horizontal fins individually or forming box, louvers and facias.
- (n) Kerbs, steps and the like.
- (o) String courses, bands, coping, bed plates, anchor blocks, plain window sills and the like.
- (p) Mouldings as in cornices, window sills etc.
- (q) Shell, dome and folded plates.
- (r) Extra for shuttering in circular work in plan.

## **5.5 ENCASING ROLLED STEEL SECTIONS**

### **5.5.1 General Requirements**

Before concrete work is started, the Engineer-in-Charge shall check that all rolled steel sections to be encased, have been erected truly in position. The sections shall be unpainted and shall be wire brushed to remove the loose rust/ scales etc. Where so specified, ungalvanised metal, having mesh or perforations large enough to permit the free passage of 12.5 mm nominal size aggregate through them shall be wrapped round the section to be encased and paid for separately.

### **5.5.2 Wrapping**

**5.5.2.1** In case of columns, the wrapping shall be arranged as illustrated in Fig. 5.27 to pass through the centre of the concreting. The wrapping of the entire length of the columns be carried out in stages and no stage shall cover more than 1.5 metre of height of columns. Successive wrappings shall be carried out only after the immediate adjacent wrapping has been encased in concrete. The surface and edges of the flanges of the steel columns shall have a concrete cover of not less than 50mm. The wrappings of the successive stages shall be tied together.

**5.5.2.2** In the case of beams and grillages, the wire mesh or expanded metal shall be wrapped round the lower flange of the beam as illustrated in Fig. 5.28 and the wrapping shall be suspended by wire hangers 5 mm diameter placed at about 1.2 metres centres. The surfaces and edges of the steel sections shall have a concrete cover of not less than 50mm. The wrapping shall pass through the centre of the concrete covering at the edges and soffits of the flanges.

### **5.5.3 Form Work shall be as prescribed in 5.2.**

### **5.5.4 Concreting**

Concrete shall consist of a mix of 1:2:4 (1 cement : 2 coarse and : 4 graded stone aggregate of 12.5 mm nominal size) unless a richer mix is specified. The mix shall be poured solidly around the steel sections and around the wrapping by vibrating the concrete into position. Consistency of concrete, Placing of concrete and its compaction, curing, finishing and strength of concrete shall be as described in 5.4.

### **5.5.5 Measurements**

The length shall be measured correct to one cm and other dimensions correct of 0.5 cm. The cement concrete shall be measured as per gross dimensions of the encasing exclusive of the thickness of plaster. No deduction shall be made for the volume of steel sections, expanded metal, mesh or any other reinforcement used therein. However, in case of boxed stanchions or girders, the boxed portion only shall be deducted. Fabric reinforcement such as expanded metal shall be measured separately in square metres stating the mesh and size of strands. The description shall include the bending of the fabric as necessary, Racking or circular cutting and waste shall be included in the description.

## **CUBE TEST FOR COMPRESSIVE STRENGTH OF CONCRETE - MANDATORY LAB TEST**

### **(Clause 5.4.9.1)**

**A-0** One sample (consisting of six cubes 15x15x15 cm shall be taken for every 20 cum or part there of concrete work ignoring any part less than 5cum or as often as considered necessary by the Engineer-in-Charge. The test of concrete cubes shall be carried out in accordance with the procedure as described below. A register of cubes shall be maintained at the site of work in Appendix C. The casting of cubes, concrete used for cubes and all other incidental charge, such as curing, carriage to the testing laboratory shall be borne by the contractors. The testing fee for the cubes, if any, shall be borne by the department.

### **A-1 Test Procedure**

#### **A-1.1 Mould**

The mould shall be of size 15 cmx15 cmx15 cm for the maximum nominal size of aggregate not exceeding 40 mm. For concrete with aggregate size more than 40 mm size of mould shall be specified by the Engineer-in-charge, keeping in view the fact that the length of size of mould should be about four times the size of aggregate.

The moulds for test specimens shall be made of non-absorbent material and shall be substantially strong enough to hold their form during the moulding of test specimens. They shall not vary from the standard dimensions by more than one percent. The moulds shall be so constructed that there is no leakage of water from the test specimen during moulding. All the cube moulds for particular site should, prior to use, be checked for accuracy in dimensions and geometric form and such test should at least be made once a year.

Each mould shall be provided with a base plate having a plane surface and made of non-absorbent material. This plate shall be large enough in diameter to support the moulds properly without leakage Glass plates not less than 6.5mm thick or plain metal not less than 12mm thick shall be used for this purpose. A similar plate shall be provided for covering the top surface of the test specimen when moulded.

**Note:** Satisfactory moulds can be made from machine or steel castings, rolled metal plates or galvanized.

### **A-1.2 Sample of Concrete**

Sample of concrete for test specimen shall be taken at the mixer or in the case of ready mixed concrete from the transportation vehicle discharge or as directed by Engineer-in-Charge. Such samples shall be obtained by repeatedly passing a scoop or pail through the discharge stream of concrete. The sampling operation should be spread over evenly to the entire discharging operation. The samples thus obtained shall be transported to the place of moulding of the specimen to counteract segregation. The concrete shall be mixed with a shovel until it is uniform in appearance. The location in the work of the batch of concrete this sampled shall be noted for further reference. In case of paving concrete, samples shall be taken from the batch immediately after deposition of the sub grade. At least five samples shall be taken from different portion of the pile and these samples shall be thoroughly mixed before being used to form the test specimen. The sampling shall be spread as evenly as possible throughout the day. When wide changes occur during concreting, additional sample shall be taken if so desired by the Engineer-in-Charge.

### **A-1.3 Preparation of Test Specimens**

The interior surfaces of the mould and base plate shall be lightly oiled before the concrete is placed in the mould. The samples of concrete obtained as described under the test specimen shall be immediately moulded by one of the following methods as indicated below:-

When the job concrete is compacted by manual methods, the test specimen shall be moulded by placing the fresh concrete in the mould in three layers, each approximately one third of the volume of the mould. In placing each scoopful of concrete the scoop shall be moved around the top edge do the mould as the concrete there sided from it, in order to ensure a uniform distribution of concrete within the mould. Each layer shall be rodded 35 times with 16 mm rod, 60 cm in length, bullet pointed at the lower end. The trokes shall be distributed in uniform manner over the cross section of the mould and shall penetrate into underlying layer. The bottom layer shall be rodded through its depth. After the top layer has been rodded, the surface of the concrete shall be struck off with a trowel and covered with a glass plate at least 6.5 mm thick or a machined plate. The whole process of moulding shall be carried out in such a manner as to preclude the change of the water cement ratio of the concrete, by loss of water either by leakage from the bottom or over flow from the top of the mould.

When the job concrete is placed by vibration and the consistency of the concrete is such that the test specimens cannot be properly moulded by hand rolling as described above, the specimens shall be vibrated to give a compaction corresponding to that of the job concrete. The fresh concrete shall be placed in mould in two layers, each approximately half the volume of the mould. In placing each scoopful of concrete the scoop shall be moved around the top edge of the mould as the concrete there slides from it, in order to ensure a symmetrical distribution of concrete within the mould. Either internal or external vibrators may be used. The vibration of each layer shall not be continued longer than is necessary to secure the required density. Internal vibrators shall only be used when the concrete is required to be compacted in layers. In compacting the first layer, the vibrators shall not be allowed to rest on the bottom of the mould. In placing the concrete for top extent that there will be no mortar loss during vibrations. After vibrating the second layer enough concrete shall be added to bring level above the top of the mould. The surface of the concrete shall then the struck off with a trowel and covered with a glass or steel plate as specified above. The whole process of moulding shall be carried out in such a manner as to preclude the alteration of water-cement ratio of the concrete by loss of water, either by leakage for the bottom or over flow from the top of the mould.

### **A-1.4 Curing and Storage of Test Specimen**

In order to ensure reasonably uniform temperature and moisture conditions during the first 24 hours for curing the specimen and to protect them from damage, moulds shall be covered with wet straw or gunny sacking and placed a storage box so constructed and kept on the

work site that its air temperature when containing concrete specimens shall remain 22°C to 33°C. Other suitable means which provide such a temperature and moisture conditions may be used.

**Note:-** It is suggested that the storage box be made of 25 mm dressed tongued and grooved timber well braced with battens to avoid warping. The box should be well painted inside and outside and should be provided with a hinged cover and padlock.

The test specimen shall be removed from the moulds at the end of 24 hours and stored in a moist condition at a temperature within 24°C to 30°C until the time of test. If storage in water is desired, a saturated lime solution shall be used.

#### **A-1.5 Testing**

The specimens shall be tested in accordance with procedure as described below: 171 SUB HEAD 5.0 : REINFORCED CEMENT CONCRETE WORK

- (a) The tests shall be made at an age of concrete corresponding to that for which the strengths are specified.
- (b) Compression tests shall be made immediately upon removal of the concrete test specimen from the curing room i.e. the test specimen shall be loaded in damp condition. The dimensions of the test specimens shall be measured in mm accurate to 0.5 mm.
- (c) The metal bearing plates of the testing machine shall be placed in contact with the ends of the test specimens. Cushioning materials shall not be used. In the case of cubes, the test specimen shall be placed in the machine in such a manner that the load is applied to sides of the specimens as cast. An adjustable bearing block shall be used to transmit the load to the test specimen. The size of the bearing block shall be the same or slightly larger than that of test specimen. The upper or lower section of the bearing block shall be kept in motion as the head of the testing machine is brought to a bearing on the test specimen.
- (d) The load shall be applied axially without shock at the rate of approximately 140 kg. per sq.cm. per minute. The total load indicated by the testing machine at failure of test specimen shall be recorded and the unit compressive strength is calculated in kg per sq. cm. using the area computed from the measured dimension of the test specimen. The type of failure and Appearance of the concrete shall be noted.

### **ADDITIONAL TESTS FOR CONCRETE**

#### **(Clause 5.4.9.2)**

**B-0** In case the concrete fails when tested as per the method prescribed in Appendix A, one or more of the following check tests may be carried out at the discretion of Engineer-in-Charge to satisfy the strength of the concrete laid. All testing expenditure shall be borne by the contractor, the number of additional tests to be carried out shall be determined by the Engineer-in-Charge. He shall be the final authority for interpreting the results of additional test and shall decide upon the acceptance or otherwise. His decision in this regard shall be final and binding. For the purpose of payment, the Hammering test results only shall be the criteria. Some of the tests are outlined below:-

#### **B-1 REBOUND HAMMER TEST**

If a rebound hammer is regularly used by trained personnel in accordance with procedure described in IS 13311 (part II) and a continuously maintained individual charts are kept showing a large number of reading and the relation between the reading and strength of concrete cubes made from the same batch of concrete, such charts may be used in conjunction with hammer readings to obtain an approximate indication of the strength of concrete in a structure for element. If calibration charts are available from manufactures, it can be used. When making rebound hammer test each result should be the average of at least 12 readings. Reading should not be taken within 20mm of the edge of concrete members and it may be necessary to distinguish between readings taken on a trowled face and those

on a moulded face. When making the tests on a precast unit, special care should be taken to bed them firmly against the impact of the hammer.

### **B-2 CUTTING CORES**

This method involves drilling and testing cores from the concrete for determination of compressive strength. In suitable circumstances, the compressive strength of the concrete in the structure may be assessed by drilling cores from the concrete and testing. The procedure used shall comply with the requirements of IS 1199 and IS 516. The points from which cores shall be taken shall be representative of the whole concrete and at least three cores shall be obtained and tested. If the average of the strength of all cores cut from the structure is less than the specified strength, the concrete represented by the cores shall be liable to rejection and shall be rejected if a static load test (B-5) either cannot be carried out or is not permitted by the Engineer-in-Charge.

### **B-3 ULTRASONIC TEST**

If an ultrasonic apparatus is regularly used by trained personnel in accordance with IS 13311 (part I) and continuously maintained individual charts are kept showing a large number of readings & the relation between the reading and strength of cubes made from the same batch of concrete, such charts may be used to obtain approximate indications of the strength of concrete in the structures. In cases of suspected lack of compaction or low cube strength the results obtained from the ultrasonic test results on adjacent acceptable section of the structures may be used for the purpose of assessing the strength of concrete in the suspected portion.

### **B- 4 LOAD TESTS ON INDIVIDUAL PRECAST UNITS**

The load tests described in this clause are intended as check on the quality of the units and should not be used as substitute for normal design procedure. Where members require special testing. Such special testing procedures shall be in a accordance with the specification. Test loads shall be applied and removed incrementally.

#### **B-4.1 Non Destructive Tests**

The unit shall be supported at its designed point of support and loaded for five minutes with a load equal to the sum of the characteristic dead load plus one and a quarter time the characteristic imposed 173 SUB HEAD 5.0 : REINFORCED CEMENT CONCRETE WORK load. The deflection is then recorded. The maximum deflection after application of the load shall be in accordance with the requirements defined by the Engineer-in-Charge. The recovery is measured five minutes after the removal of the load and the load then reemployed. The percentage recovery after the second loading shall be not less than that after the first loading nor less than 90% of the deflection recorded during the second loading. At no time during the tests, shall the unit show any sign of weakness or faulty construction as defined by the Engineer-in-Charge in the light of reasonable interpretation of relevant data.

#### **B-4.2 Destructive Tests**

The unit is loaded while supported at its design point of support and must not fail at its design load for collapse, within 15 minutes of time when the test load becomes operative. A deflection exceeding 1/40 of the test span is regarded as failure of the unit.

#### **B-4.3 Special Tests**

For very large units or units not readily amenable to the above test e.g. columns, the precast parts of composite beams and members designed for continuity or fixity, the testing arrangements shall be agreed upon before such units are cast.

## **B-5 Load Test of Structures or Parts of Structures**

The test described in this clause are intended as a check where there is a doubt regarding structural strength. Test loads are to be applied and removed incrementally.

### **B-5.1 Age at Tests**

The test is to be carried as soon as possible after the expiry of 28 days from the time of placing of the concrete. When the test is for a reason other than the quality of concrete in the structure being in doubt, the test may be carried out earlier, provided that the concrete has already reached its specified characteristic strength.

### **B-5.2 Test Load**

The test loads to be applied for the limit state of deflection and local damage are the appropriate design loads i.e., the characteristic dead and superimposed loads. When the limit state of collapse is being considered the test load shall be equal to the sum of characteristic dead load plus one and a quarter times the characteristic imposed load and shall be maintained for a period of 24 hours. In any of the test temporary supports of sufficient strength to take the whole load shall be placed in position underneath but not in contact with the members being tested. Sufficient precautions must be taken to safeguard persons in the vicinity of the structure.

### **B-5.3 Measurement During Tests**

Measurements of deflection and crack width shall be taken immediately after applications of the load and, in the case of 24 hour sustained load test, at the end of 24 hour loaded period, after removal of the load and after 24 hour recovery period. Sufficient measurements shall be taken to enable side effect to be taken in account. Temperature and weather conditions shall be recorded during the tests.

### **B-5.4 Assessment of Results**

In assessing the strength of a structure or a part of the structure following a loading test, the possible effects of variation in temperature and humidity during the period of the test shall be considered. The following requirements shall be met:

(a) The maximum width of any crack measured immediately on application of the test load for local damage, is to be not more than  $2/3$  of the value of the appropriate limit state requirement. (b) For members spanning between two supports the deflection measured immediately on application of the test load for deflection is to be not more than  $1/500$  of the effective span limits shall be agreed upon before testing cantilevered portions of structure.

CPWD SPECIFICATIONS 2009 174

(c) If maximum deflection in mm shown during 24 hour under load is less than  $40L^2/D$  where L is effective span in mm and D is overall depth of construction in mm, it is not necessary for the recovery to be measured and the requirement (D) does not apply, and

(d) If within 24 hours of the removal of test load for collapse as calculated in clause (a) a reinforced concrete structure does not show a recovery of at least 75 per cent of the maximum deflection shown during the 24 hour under load, the loading should be repeated. The structure should be considered to have failed to pass the test if the recovery after second loading is not at least 75 per cent of the maximum deflection shown during the second loading.

## **B-6 DETERMINATION OF WATER SOLUBLE AND ACID SOLUBLE CHLORIDES IN CONCRETE**

Determination of water soluble and acid soluble chlorides in Concrete shall be done as per method of test given in IS 14959 (Part 1) which covers volumetric method of test as described below : (a) Quality of reagents



Unless otherwise specified, pure chemicals of analytical reagent grade and distilled water (see IS 1070) shall be used in the test.

(b) Nitric Acid (HNO<sub>3</sub>) Concentrated (Specific Gravity 1.42) Prepare the solution, (6N (approximately), by diluting 38ml of concentrated Nitric acid to 100 ml with distilled water.

(c) Ferric Alum(FeNH<sub>4</sub> (SO<sub>4</sub>)<sub>2</sub> 12 H<sub>2</sub>O)

Dissolve 10 g of ferric alum in 100 ml of distilled water and add 1 ml of Nitric acid.

(d) Potassium Chromate 5% Solution

Dissolve 5 g of potassium chromate (K<sub>2</sub> CrO<sub>4</sub>) 100 ml of distilled water to form 5% Solution.

(e) Nitrobenzene

(f) Silver Nitrate (AgNO<sub>3</sub>)Solution, 0.02 N

Weigh 1.7 g of silver nitrate, dissolve in distilled water and dilute to 500 ml in a volumetric flask. Standardize the silver nitrate solution against 0.02 N sodium chloride solution using potassium chromate solution as indicator ( 5 percent m/v) in accordance with the procedure given in IS 3025 (Part 32).

(g) Ammonium thiocyanate (NH<sub>4</sub> SCN) Solution

Weigh 1.7 g of ammonium thiocyanate (NH<sub>4</sub> SCN) and dissolve in one litre of distilled water in a volumetric flask. Shake well and standardize by titrating with 0.02 N silver nitrate solution using ferric alum solution as an indicator. Adjust the normality exactly to 0.02 N.

(h) Sodium chloride (NaCl) 0.02N Weigh 1.1692 g of sodium chloride (NaCl) dried at 105 +/- 2°C, dissolve in distilled water and make upto 1000 ml in a volumetric flask.

(i) Use of Filter Paper

(j) In the methods prescribed in this standard, relative numbers of Watman filter paper only have been prescribed since these are commonly used. However, any other suitable brand of filter papers with equivalent porosity may be used.

(k) Procedure for Water Soluble Chloride

Weigh 1 000+/-5 g of fresh mortar or concrete sample in a 2 litre capacity beaker and add 500 ml of distilled water (chloride free). Stir the mixture vigorously for 15 minutes. After allowing the into a clean dry 250 ml capacity beaker. Immediately, filter the solution through Watman filter paper No.1 and collect the filtrate.

Pipette 50 ml of filtrate in a 250 ml capacity conical flask. Add 5 ml of 6 N Nitric acid. Add a known volume (X), preferably 25 ml of nitrobenzene. Shake vigorously to coagulate the precipitate. Titrate the excess silver nitrate with 0.02 N ammonium thiocyanate solution until a permanent faint reddish brown colour appears. Note down the volume (Y) of ammonium thiocyanate used.

(l) Procedure for Acid Soluble Chloride

Weigh about 1000 +/- 5 g of the fresh mortar or concrete sample in a 2 litre capacity beaker and add 50 ml of 6 N nitric acid and 450 ml of distilled water (chloride free) after stirring for few Minutes. Stir the mixture vigorously for 15 minutes. After allowing the mixture to stand for 10 to 15 minutes for settling, decant about 200 ml of the supernatant solution into a clean dry 250 ml capacity beaker. Immediately, filter the solution through Watman filter paper No.1 and collect the

filtrate. Pipette 50 ml of filtrate in a 250 ml capacity conical flask. Add 5 ml of 6 N nitric acid. Add a known volume ( X ) preferably 25 ml of standard silver nitrate solution. Add 1 ml ferric alum and 5 ml of nitrobenzene Shake vigorously to coagulate the precipitate. Titrate the excess silver nitrate with 0.02 N ammonium thiocyanate solution until a permanent faint reddish brown colour appears. Note down the volume (Y) of ammonium thiocyanate used.

(m) Calculation Calculate the percentage of chloride(acid soluble/water soluble) by mass of mortar or concrete as follows:

Chloride, percent =  $0.00071 (X - Y)$ , Where

X = volume of silver nitrate added, in ml; and

Y = volume of 0.02 N ammonium thiocyanate consumed.

**Note:** Interference of silver chloride particles (which are generated in situ) in titration by reacting with thiocyanants can be avoided by the addition of nitrobenzenes which forms a film on silver chloride articles.

APPENDI

**REGISTER OF WORK TEST OF CONCRETE**

(Clause A-O of Appendix A)

(a) Name of work	Concrete mix, (by volume)	Compressive strength in kg/cm <sup>2</sup> on 7 days
(b) Name of Contractor	1:1:2	210
(c) Agreement No.	1:1.5:3	175
(d) Sample No.	1:2:4	140
(e) Identification mark		
(f) Portion of work any quantity represented by sample		
(g) Date and time of casting cube		
(h) Proportion of mix/ grade of concrete		

**7 Days' Test**  
(Clause 5.4.10.3)

(1) Due date of test	Cube No.
(2) Actual date of test	
(3) (a) Minimum strength	
(b) Maximum strength	
(c) Average strength of three cubes	
(d) Difference between 3a and 3b	
(e) Difference in % age in terms of average strength i.e $\frac{3b-3a}{3c} \times 100$	
(4) Specified compressive strength of concrete mix used	
(5) (a) If 3(e) is more than 30%	Sample is not acceptable, then 28 days strength test shall be carried out.
(b) If 3(e) is equal to or less than 30% then proceed as below:-	
(i) Difference between column 4 specified compressive strength and column 3 (c) i.e., actual average is higher, it will be denoted (+) and (-) if it is less.	
(ii) Difference in column 5(b) (i) terms of % age of specified strength	$\frac{3(c)-(4)}{4} \times 100\%$
(iii) If the difference in column 5(b) (i) is +ve and the same in terms of % age of specified strength (4) i.e., value of col. 5(b) (ii) is within (+15% range)	Acceptable & strength is considered in order

### REGISTER OF WORK TEST FOR CONCRETE

(a) Name of Work	Concrete mix, (By volume)	Compressive strength kg/cm <sup>2</sup> in 28 days
(b) Name of contractor	1:1:2	315
(c) Agreement No.	1:1.5:3	265
(d) Sample No.	1:2:4	210
(e) Identification mark		
(f) Portion of work any quantity represented by sample		
(g) Date and time of casting cube		
(h) Proportion of mix/Grade of concrete		

#### 28 Days' Test (Clause 5.4.10.4)

(1) Due date of test	Cube No.
(2) Actual date of test	
(3) Actual compressive strength of cubes (min. no. of cubes to be tested –three)	
(a) Minimum strength	
(b) Maximum strength	
(c) Average strength of three cubes	
(d) Specified compressive strength of concrete mix used	
(e) 70% specified strength	i.e. 70% of 3(d)
(f) 130% of specified strength	i.e. 130% of 3(d)
(4) If 3(b) = 3(f) and 3(a) ≥ 3(e)	Value of 3(c) shall be compressive strength of sample
(5) If 3 (c) is more than 3(f)	EE may order further investigation
(6) If any test value exceeds 3(f)	It should be restricted to 3(f) for computation of strength
(7) If 3 (c) ≥ 3(d) but < 3(f)	Strength is in order and concrete accepted at full rates.
(8) If 3 (c) < 3(d) and > 3(e)	Concrete may be accepted at reduced rates in accordance with para 5.4.13.2
(9) If 3(c) < 3(e)	Work represented by this sample shall be rejected and action taken as prescribed in clause 5.4.10.4

## TYPICAL SET UP OF STEEL WALL FORM WORK

Sub Head : R.C.C. (Form Work)  
Clause : 5.2.3.6

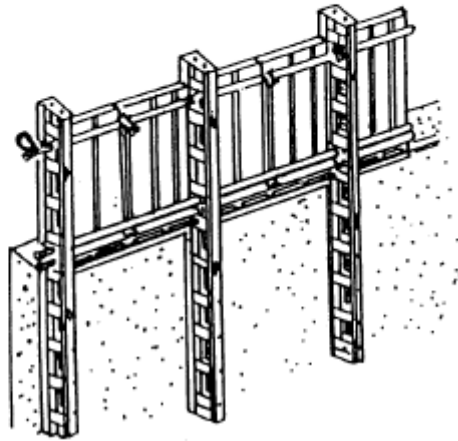

Fig. 5.1A : Single Sided Wall Form (Adjustable)

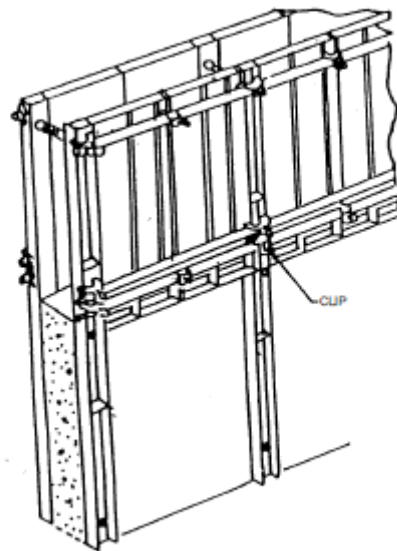
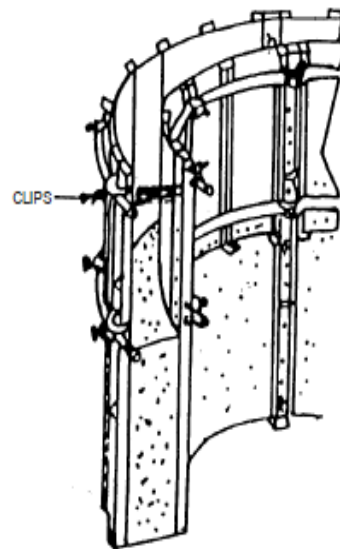

Fig. 5.1B : Double Sided Wall Form

## WALL FORM

Sub Head : R.C.C. (Form Work)  
Clause : 5.2.3.6



All Members are of Steel

Fig. 5.2 : Adjustable Curved Wall Form (Double Sided)

## EXPANSION JOINTS (CONTD.)

Sub Head : R.C.C.  
Clause : 5.4.5

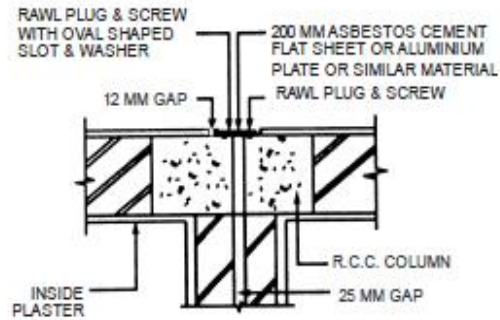

Fig. 5.19 : Typical Details of Expansion Joint Covering on Outer Face of Columns (Plan)

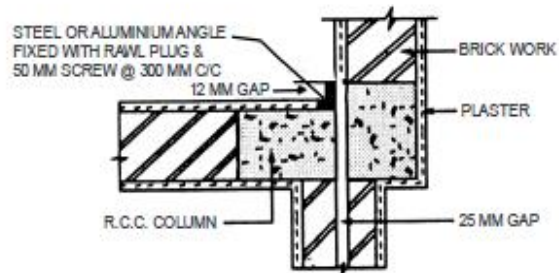

Fig. 5.20 : Typical Details of Expansion Joints at Corner Column

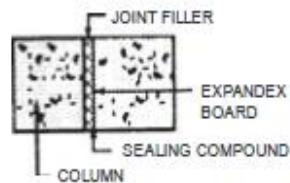

Fig. 5.21 : Typical Details of Expansion Joint at Isolated Twin Columns

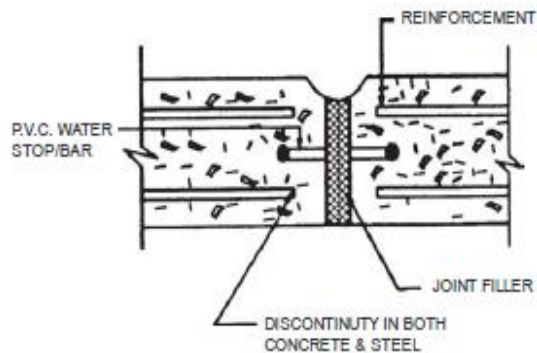
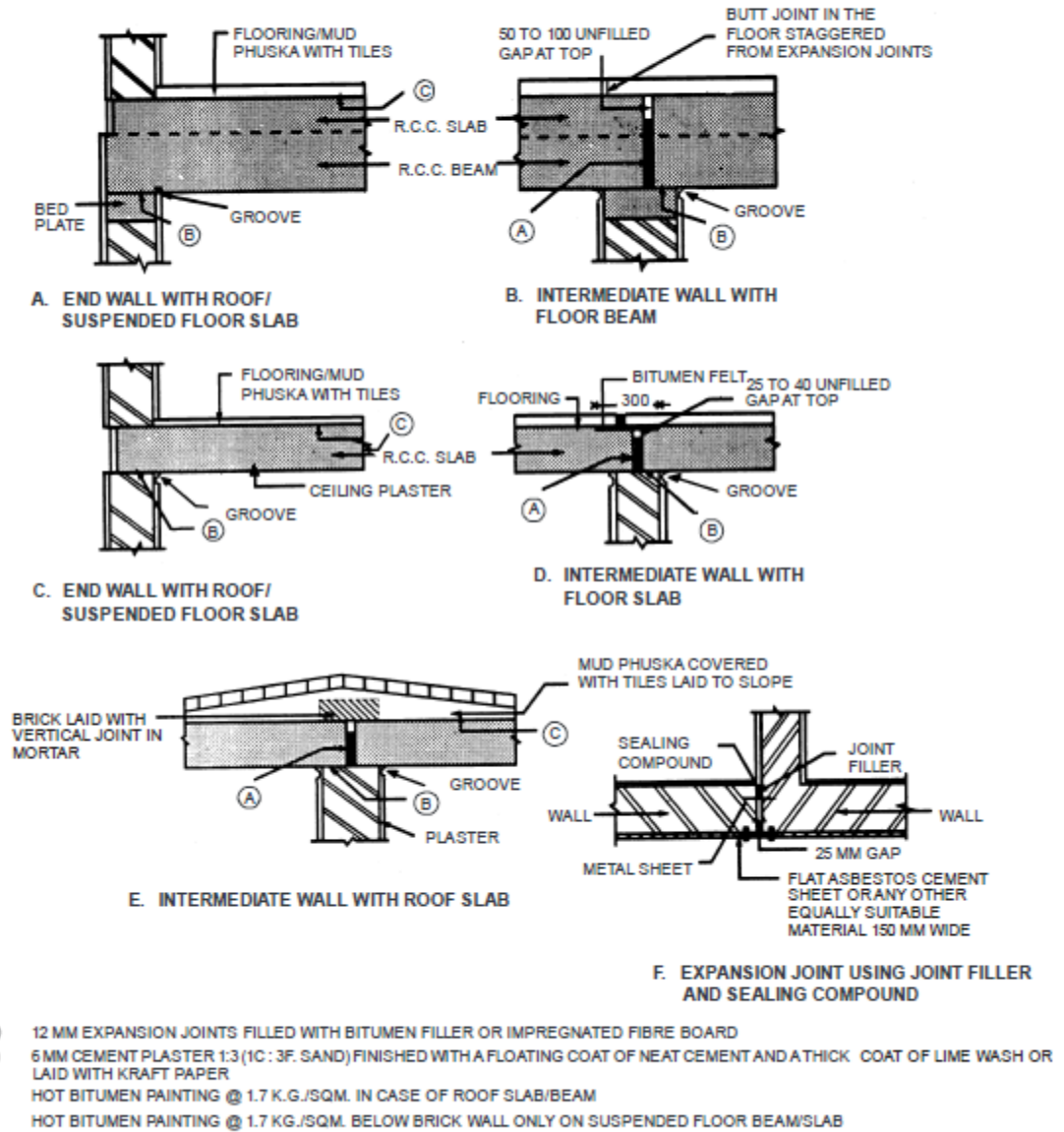

Fig. 5.22 : Expansion Joint Subjected to Water Pressure (For water Tanks)

## EXPANSION JOINTS (CONTD.)

Sub Head : R.C.C.  
Clause : 5.4.5



Drawing not to scale  
All dimensions are in mm

Fig. 5.23 : Expansion Joint (Contd.)

## **SUB HEAD : 6.0 BRICK WORK**

### **6.0. TERMINOLOGY**

#### **Bond**

The arrangement of the bricks in successive courses to tie the brick work together both longitudinally and transversely. The arrangement is usually designed to ensure that no vertical joint of one course is exactly over the one in the next course above or below it, and there is greatest possible amount of lap.

#### **Bed Joint**

Horizontal joint in brick work or masonry.

#### **Closer**

Any portion of a brick used in constructing a wall, to close up the bond next to the end brick of a course (See Fig. 6.3).

#### **Coping or Weathering**

The cover applied over or the geometrical form given to a part of structure to enable it to shed rain water.

#### **Corbel**

A cantilever projecting from the face of a wall to form a bearing (see Fig. 6.1D)

#### **Cornice**

Horizontal or ornamental feature projecting from the face of a wall (see Fig. 6.1D)

#### **Course**

A layer of bricks including bed mortar.

#### **Cross joint**

A joint other than a bed joint normal to the wall face.

#### **Efflorescence**

A powdery incrustment of salts left by evaporation. This may be visible on the surface or may be below surface. In the latter case, this is termed as crypto Efflorescence.

#### **Header**

A brick laid with its length across the wall.

#### **Indenting**

The leaving recesses into which future work can be bonded.

#### **Jamb**

The part of the wall at the side of an opening.

#### **Joint**

A junction of bricks.

#### **Jointing**

The operation of finishing joints as the masonry work proceeds.

#### **Pier**

A thickened section forming integral part of the wall placed at intervals along the wall primarily to increase the stiffness of the wall or to carry a vertical concentrated load. The thickness of a pier is the over all thickness including the thickness of the wall, or when bonded into one leaf of a cavity wall the thickness obtained by treating this leaf as an independent wall (see Fig. (6.1A, 6.1B)).

#### **Pillar**

Pillar means a detached masonry support. This can be rectangular, circular, elliptical etc. In case of rectangular pillar, the breadth shall not exceed three times the thickness and thickness itself shall not exceed more than thrice the length of brick (See Fig. 6.1C).

#### **Quoin**

An external corner in brick work, the term may also denote the brick used to form the quoin.

#### **Scaffolding**

A temporary erection of timber or steel work used in the construction, alteration, demolition or repairs of a building to support or to attend of the hoisting or lowering of workmen, their



tools and materials Scaffoldings are of two types, namely single and double scaffoldings. Single scaffolding consists of a row of verticals connected to wall by horizontal supported on and tied to the structure. Double scaffolding consists of two rows of verticals secured or leashed together with horizontal and diagonal bracings forming essentially a structure independent of the building. It may also connect to the structure at convenient points for the sake of better stability.

**Sill**

A brick work forming the lower boundary of door or window opening (see Fig. 6.1D).

**Spandrel**

The space between the haunches and the road decking of an arch.

**Strecher**

A brick laid with its length in the direction of the wall.

**String course**

A horizontal course projecting from a wall usually introduced at every floor level or windows or below parapet for imparting architectural appearance to the structure and also keeping off the rain water. (see Fig. 6.1D).

**Templet**

A pattern of sheet metal used as a guide for setting out specific section and shape.

**Toothing**

Bricks left projecting in alternate courses to bond with future work.

**Wall joint**

A joint parallel to the wall face.

**6.1 BRICKS/BRICK TILES/BRICK BATS/MECHANIZED AUTOCLAVE FLY ASH LIME BRICK**

Bricks used in the masonry may be of the following type.

(a) The **Common Burnt Clay Bricks** shall conform to IS:1077 and shall be hand moulded or machine moulded. They shall be free from nodules of free lime, visible cracks, flaws warpage and organic matter, have a frog 100 mm in length 40 mm in width and 10 mm to 20 mm deep on one of its flat sides. Bricks made by extrusion process and brick tiles may not be provided with frogs. Each brick shall be marked (in the frog where provided) with the manufacturer's identification mark or initials.

(b) **Fly Ash Lime Bricks (FALG Bricks)** : The Fly Ash Lime Bricks (FALG Bricks) shall conform to IS 2894. Visually the bricks shall be sound, compact and uniform in shape free from visible cracks, warpage, flaws and organic matter. The bricks shall be solid and with or without frog on one of its flat side.

**Fly Ash:** Fly ash shall conform to IS 3812.

**Note:** This item will be operated only for load bearing structure upto 2 storeys and for non-load bearing walls 23 cms thick for multi-storeyed building's. Bottom ash used as replacement of sand shall not have more than 12% loss on ignition when tested. **Sand:** Deleterious materials, such as clay and silt in the sand shall preferably be less than 5%.

**Lime:** Lime shall conform to class 'C' hydrated lime of IS 712.

**Additives:** Any suitable additive considered not detrimental to the durability of bricks may be used. (c) **Clay Fly Ash Bricks:** The clay fly ash bricks shall conform to IS 13757. The bricks shall be sound, compact and uniform in shape and colour. Bricks shall have smooth rectangular faces with sharp and square corners. The bricks shall be free from visible cracks, flaws, warpage, nodules of free lime and organic matter, the bricks shall be hand or machine moulded. The bricks shall have frog of 100 mm in length 40 mm width and 10 to 20 mm deep on one of its flat sides. If made by extrusion process may not be provided with frogs. Fly Ash shall conform to grade I or grade II of IS 3812.

(d) **Calcium Silicate Bricks:** The bricks shall conform to IS 4139. The Calcium silicate bricks shall be sound, compact and uniform in shape. Bricks shall be free from visible

cracks, warpage, organic matter, large pebbles and nodules of free lime. Bricks shall be solid and with or without frog. The bricks shall be made of finely grounded sand siliceous rock and lime. In addition limited quantity of fly ash conforming to IS 3812 may be used in the mix. These bricks are also known as Fly Ash Sand Lime bricks in the construction industry.

(e) **Tile Brick:** The bricks of 4 cm height shall be moulded without frogs. Where modular tiles are not freely available in the market, the tile bricks of F.P.S. thickness 44 mm (1-3/4") shall be used unless otherwise specified.

(f) **Brick Bats:** Brick bats shall be obtained from well burnt bricks.

(g) **Mechanized Autoclave Fly Ash Lime Brick:** These bricks shall be machine moulded and prepared in plant by appropriate proportion of fly ash and lime. The autoclave fly ash bricks shall conform to IS 12894. Visually, the bricks shall be sound, compact and uniform shape, free from visible cracks warpage and organic matters. The brick shall be solid with or without frog, and of 100/80 mm in length, 40 mm width and 10 to 20 mm deep one of its flat side as per IS 12894. The brick shall have smooth rectangular faces with sharp corners and shall be uniform in shape and colour. Fly ash shall conform to IS 3812 and lime shall conform to class 'C' hydrated lime of IS 712.

### 6.1.1 Dimensions

The brick may be modular or non-modular. Sizes for both types of bricks/tiles shall be as per Table 6.1. While use of modular bricks/tiles is recommended, non-modular (FPS) bricks/tiles can also be used where so specified. Non-modular bricks/tiles of sizes other than the sizes mentioned in Table 6.1 may also be used where specified.

TABLE 6.1

Type of Bricks/ Tiles	Nominal Size mm	Actual Size mm
Modular Bricks	200 × 100 × 100 mm	190 × 90 × 90 mm
Modular tile bricks	200 × 100 × 40 mm	190 × 90 × 40 mm
Non-modular tile bricks	229 × 114 × 44 mm	225 × 111 × 44 mm
Non-modular bricks	229 × 114 × 70 mm	225 × 111 × 70 mm

### 6.1.2 Classification

Bricks/Brick tiles shall be classified on the basis of their minimum compressive strength as given below :

TABLE 6.2

Class Designation	Average compressive strength			
	Not less than		Less than	
	N/mm <sup>2</sup>	(kgf/cm <sup>2</sup> )	N/mm <sup>2</sup>	(Kgf/cm <sup>2</sup> )
12.5 (125)	12.5	(125)	15.0	150
10 (100)	10	(100)	12.5	125
7.5 (75)	7.5	(75)	10	100
5 (50)	5	(50)	7.5	75
3.5 (35)	3.5	(35)	5.0	50

The bricks shall have smooth rectangular faces with sharp corner and shall be uniform in colour and emit clear ringing sound when struck.

(Note: Upper limits specified in Table 6.2 are for calculating the average compressive strength in accordance with Appendix B of Chapter 6).

### 6.1.3 Sampling and Tests

Samples of bricks shall be subjected to the following tests :

- Dimensional tolerance.
- Water absorption.
- Efflorescence.

(d) Compressive strength.

**6.1.3.1 Sampling:** For carrying out compressive strength, water absorption, efflorescence and dimensional tests, the samples of bricks shall be taken at random according to the size of lot as given in Table 6.3 below. The sample thus taken shall be stored in a dry place until tests are made. For the purpose of sampling, the following definition shall apply.

(a) Lot: A collection of bricks of same class and size, manufactured under relatively similar conditions of production. For the purpose of sampling a lot shall contain a maximum, of 50,000 bricks. In case a consignment has bricks more than 50,000 of the same classification and size and manufactured under relatively similar conditions of production, it shall be divided into lots of

50,000 bricks or part thereof.

(b) Sample: A collection of bricks selected for inspection and/or testing from a lot to reach the decision regarding the acceptance or rejection of the lot.

(c) Defective: A brick failing to meet one or more of the specified requirements.

**6.1.3.2** The samples shall be taken as below:

(i) **Sampling from a Stack:** When it is necessary to take a sample from a stack, the stack shall be divided into a number of real or imaginary sections and the required number of bricks drawn from each section. For this purpose bricks in the upper layers of the stack shall be removed to enable units to be sampled from places within the stack.

**Note:** For other methods of sampling i.e. sampling in motion and sampling from lorries or trucks, IS :5454 may be referred. Scale of sampling and criteria for conformity for visual and dimensional characteristics:—

**Visual characteristics:** The bricks shall be selected and inspected for ascertaining their conformity to the requirements of the relevant specification. The number of bricks to be selected from a lot shall depend on the size of lot and shall be in accordance of Col. 1 and 2 of Table 6.3 for visual characteristics in all cases and dimensional characteristics if specified for individual bricks.

(ii) **Visual Characteristics:** All the bricks selected above in accordance with Col. 1 and 2 of Table 6.3 shall be examined for visual characteristics. If the number of defective bricks found in the sample is less than or equal to the corresponding number as specified in Col. 3 of Table 6.3 the lot shall be considered as satisfying the requirements of visual characteristics, otherwise the lot shall be deemed as not having met the visual requirements.

(iii) **Dimensional Characteristics:** The number of bricks to be selected for inspecting the dimensions and tolerance shall be in accordance with Col. 1 and 4 of Table 6.3. These bricks will be divided into groups of 20 bricks at random and each of the group of 20 bricks thus formed will be tested for all the dimensions and tolerances. A lot shall be considered having found meeting the requirements of dimensions and tolerance if none of the groups of bricks inspected fails to meet the specified requirements.

**TABLE 6.3**  
**Scale of Sampling and Permissible Number of Defectives for Visual and Dimensional Characteristics**

<i>No. of bricks in the lot</i>	<i>For characteristics specified for individual bricks</i>		<i>For dimensional characteristics for group of 20 bricks</i>
	<i>No. of bricks to be selected</i>	<i>Permissible no. of defective in the sample</i>	<i>No. of bricks to be selected</i>
<i>(1)</i>	<i>(2)</i>	<i>(3)</i>	<i>(4)</i>
2001—10000	20	1	40
10001—35000	32	2	60
35001—50000	50	3	80

**Note:** In case the lot contains 2000 or less bricks the sampling shall be as per decision of the Engineer-in-Charge.

### Brick Tiles

760 to 840 mm (800 ± 40 mm) for 40 mm high brick tiles In case of non-modular bricks, % age tolerance will be ± 2% for group of 20 numbers of class 10bricks, and ± 4% for other class of bricks.

**6.1.3.4 Compressive Strength:** The bricks, when tested in accordance with the procedure laid down in Appendix B of Chapter 6 shall have a minimum average compressive strength for various classes as given in Table 6.2. The compressive strength of any individual brick tested shall not fall below the min. average compressive strength specified for the corresponding class of brick by more than 20%. In case compressive strength of any individual brick tested exceeds the upper limit specified in Table 6.2 for the corresponding class of bricks, the same shall be limited to upper limit of the class as specified in Table 6.2 for the purpose of calculating the average compressive strength.

**6.1.3.5 Water Absorption:** The average water absorption of bricks when tested in accordance with the procedure laid down in Appendix C of Chapter 6 shall be not more than 20% by weight.

**6.1.3.6 Efflorescence:** The rating of efflorescence of bricks when tested in accordance with the procedure laid down in Appendix D of Chapter 6 shall be not more than moderate.

### 6.1.4 Sewer Bricks

**6.1.4.1** Sewer bricks are intended for the lining of walls, roofs and floors of sewers used for ordinary sanitary (domestic) sewage. The general practice in the country is also to utilize common building bricks in the construction of sewers which is not satisfactory. However, these sewer bricks may not be suitable for sewers dealing with industrial effluent (sewage) for which the use of acid resistant bricks in accordance with IS 4860 may be considered. Sewer bricks shall conform to IS 4885.

#### 6.1.4.2 Dimensions and Tolerances

**Dimensions:** The standard sizes of the sewer bricks shall be as follows:

<i>Length mm</i>	<i>Width mm</i>	<i>Height mm</i>
190	90	90
190	90	40

<i>Dimensions</i> <i>mm</i>	<i>Total tolerance</i> <i>for 20 bricks</i> <i>mm</i>
190	$\pm 80$
90	$\pm 40$
40	$\pm 40$

**6.1.4.3 Compressive Strength:** The average compressive strength obtained on a sample of sewer bricks when tested in accordance with the procedure laid down in IS 3495 (Part I) shall be not less than 17.5 N/mm<sup>2</sup> (175 kgf/cm<sup>2</sup> approximately) and the individual strength of any brick shall be not less than 16 N/mm<sup>2</sup> (160 kgf/cm<sup>2</sup> approximately).

**6.1.4.4 Water Absorption:** The average value of water absorption for five bricks after 24 h cold water immersion test when tested in accordance with IS 3495 (Part 2) shall not exceed 10 per cent of the average dry weight of the brick and the absorption for any individual brick shall not exceed 12 per cent.

**6.1.4.5 Efflorescence:** When the bricks are tested in accordance with the method laid down in IS 3495(Part 3), the rating of efflorescence shall not be more than 'slight'.

### 6.1.5 Burnt Clay Perforated Building Bricks

**6.1.5.1 General Quality:** The bricks shall be made of suitable clay and shall be thoroughly burnt at the maturing temperature of clay. They shall be free from cracks, flaws and nodules of free lime. They shall have rectangular face with sharp straight edge at right angle. They shall be of uniform colour and texture. These bricks generally should conform to IS 2222.

**6.1.5.2 Dimensions and Tolerances:** The standard size of burnt clay perforated bricks shall be as follows:

	<i>Length</i> <i>(L)</i> <i>mm</i>	<i>Width</i> <i>(W)</i> <i>mm</i>	<i>Height</i> <i>(H)</i> <i>mm</i>
Modular	190	90	90
Non Modular	230	110	70

The permissible tolerances on the dimensions shall be as follows:

<i>Dimension</i> <i>mm</i>	<i>Tolerance</i> <i>mm</i>
70, 90	$\pm 4$
110, 190	$\pm 7$
230	$\pm 10$

**Note:** The tolerances specified above shall apply to measurements on individual bricks.

## 6.2 BRICK WORK

### 6.2.1 Classification

The brick work shall be classified according to the class designation of bricks used.

### 6.2.2 Mortar

The mortar for the brick work shall be as specified, and conform to accepted standards. Lime shall not be used where reinforcement is provided in brick work.

### **6.2.3 Soaking of Bricks**

Bricks shall be soaked in water before use for a period for the water to just penetrate the whole depth of the bricks. Alternatively bricks may be adequately soaked in stacks by profusely spraying with clean water at regular intervals for a period not less than six hours. The bricks required for masonry work using mud mortar shall not be soaked. When the bricks are soaked they shall be removed from the tank sufficiently early so that at the time of laying they are skin-dry. Such soaked bricks shall be stacked on a clean place where they are not again spoiled by dirt earth etc.

**Note I:** The period of soaking may be easily found at site by a field test in which the bricks are soaked in water for different periods and then broken to find the extent of water penetration. The least period that corresponds to complete soaking will be the one to be allowed for in construction work **Note II :** If the bricks are soaked for the required time in water that is frequently changed the soluble salt in the bricks will be leached out, and subsequently efflorescence will be reduced.

### **6.2.8 Measurements**

**6.2.8.1** Brick work shall be measured in cubic metres unless otherwise specified. Any extra work over the specified dimensions shall be ignored. Dimensions shall be measured correct to the nearest 0.01 m i.e. 1 cm. Areas shall be calculated to the nearest 0.01 sq mtrs and the cubic contents shall be worked out to the nearest 0.01 cubic metres.

**6.2.8.2** Brick work shall be measured separately in the following stages:

- (a) From foundation to floor one level (Plinth level)
- (b) Plinth (floor one) level to floor two level
- (c) Between two specified floor levels above floor two level

**Note :** (i) Brick work in parapet walls, mumty, lift machine room and water tanks constructed on the roof upto 1.2 m height above roof shall be measured together with the corresponding work of the floor next below.

**6.2.8.3** No deductions or additions shall be done and no extra payment made for the following :

**Note :** Where minimum area is defined for deduction of an opening, void or both, such areas shall refer only to opening or void within the space measured.

- (a) Ends of dissimilar materials (that is, joists, beams, lintels, posts, girders, rafters, purlins, trusses, corbels, steps, etc.); up to 0.1 m<sup>2</sup> in section;
- (b) Opening up to 0.1 m<sup>2</sup> in area (see Note);
- (c) Wall plates, bed plates, and bearing of slabs, chajjas and the like, where thickness does not exceed 10 cm and bearing does not extend over the full thickness of wall;
- (d) Cement concrete blocks as for hold fasts and holding down bolts;
- (e) Iron fixtures, such as wall ties, pipes upto 300 mm diameter and hold fasts for doors and windows; and
- (f) Chases of section not exceeding 50 cm in girth.
- (g) Bearing portion of drip course, bearing of moulding and cornice.

**Note :** In calculating area of an opening, any separate lintel or sills shall be included with the size of the opening but end portions of lintel shall be excluded. Extra width of rebated reveals, if any, shall also be excluded.

**6.2.8.4** Walls half brick thick and less shall each be measured separately in square metres stating thickness.

**6.2.8.5** Walls beyond half brick thickness shall be measured in multiples of half brick which shall be deemed to be inclusive of mortar joints. For the sizes of bricks specified in 6.1.1, half brick thickness shall mean 100 mm for modular and 115 mm for non-modular bricks

Where fractions of half brick occur due to architectural or other reasons, measurement shall be as follows :

- (a) upto 1/4th brick-actual measurements and
- (b) exceeding 1/4 brick-full half bricks.

**6.2.8.6** String courses, projecting pilasters, aprons, sills and other projections shall be fully described and measured separately in running metres stating dimensions of each projection.

**6.2.8.7** Square or rectangular pillars shall be measured separately in cubic metres in multiple of half brick.

**6.2.8.8** Circular pillars shall be measured separately in cubic metres as per actual dimensions.

**6.2.8.9** Brick work curved on plan shall be measured like the brick work in straight walls and shall include all cutting and wastage of bricks, tapered vertical joints and use of extra mortar, if any. Brick work curved on plan to a mean radius not exceeding six metres shall be measured separately and extra shall be payable over the rates for brick work in straight walls. Nothing extra shall be payable if the mean radius of the brick work curved in plan exceeds six metres.

**6.2.8.10** Tapered walls shall be measured net as walls and extra payment shall be allowed for making tapered surface for brick work in walls.

**6.2.8.11** Brick work with brick tiles shall be measured and paid for separately.

#### **6.4 HALF BRICK WORK**

Brick work in half brick walls shall be done in the same manner as described above in 6.2.4 except that the bricks shall be laid in stretcher bond. When the half brick work is to be reinforced, 2 Nos. M.S. bars of 6 mm dia., shall be embedded in every third course as given in the item (the dia of bars shall not exceed 8 mm). These shall be securely anchored at their end where the partitions end. The free ends of the reinforcement shall be keyed into the mortar of the main brick work to which the half brick work is joined. The mortar used for reinforced brick work shall be rich dense cement mortar of mix 1:4 (1 cement: 4 coarse sand). Lime mortar shall not be used. Over laps in reinforcement, if any shall not be less than 30 cm. The mortar interposed between the reinforcement bars and the brick shall not be less than 5 mm. The mortar covering in the direction of joints shall not be less than 15 mm.

##### **6.4.1 Measurements**

The length and height of the wall shall be measured correct to a cm. The area shall be calculated in sqm. where half brick wall is joined to the main walls of one brick or greater thickness

#### **6.6 HONEY COMB BRICK WORK**

The honeycomb brick work shall be done with specified class of brick, laid in specified mortar. All joints and edges shall be struck flush to give an even surface. The thickness of the brick honeycomb work shall be half-brick only, unless otherwise specified. Openings shall be equal and alternate with half brick laid with a bearing of 2 cm on either side.

##### **6.6.1 Measurements**

The length and height shall be measured correct to a cm. Area shall be calculated in square metres correct to two places of decimal. Honeycomb openings shall not be deducted.

**Note:- For further detail refer CPWD specification volume 1, Sub Head 6.0**

## **SUB HEAD: 7.0 STONE WORK**

### **7.0 TERMINOLOGY**

#### **Ashlar**

Stone masonry using dressed square stone blocks of given dimensions having faces perpendicular to each other and laid in courses.

#### **Bed Joint**

The joint where one stone presses on another for example, a horizontal joint in a wall or radiating joint between the voussoirs or arch (See Fig. 7.1 and 7.13)

#### **Block**

(a) Hollow (Open and Closed Cavity) Block: A concrete masonry unit with any one of the external dimension greater than the corresponding dimension of a brick and having one or more large holes or cavities which either pass through the block (open cavity) or do effectively pass through the block (closed cavity) and having the solid material between 50% and 75% of the total volume of the block calculated from the overall dimensions.

(b) Solid Block: A concrete masonry unit with external dimensions greater than corresponding dimension of a brick and having solid material not less than 75% of the total volume of the block calculated from over all dimension.

#### **Bond**

An interlocking arrangement of structural units in a wall to ensure stability.

#### **Bond Stone (through Stone)**

Selected long stone used to hold a wall together transversely (See Fig. 7.8).

#### **Corbel**

Stone bonded well into the wall with part of it projecting out of the face of wall to form a bearing surfaces.

#### **Cornice**

A horizontal moulded projection which crowns or finishes either a wall, any horizontal division of wall, or any architectural feature (See Fig. 7.1C).

#### **Cramp**

A small piece of metal or the hardest or toughest stone procurable, sunk in mortices and fixed across joints as additional ties. The ends of metal cramps are bent at right angles and stone cramps are dovetailed (See Fig. 7.1B).

#### **Course**

A layer of stones in wall including the bed mortar.

#### **Dowels**

Dowels are small sections of metal, stone or pebbles bedded with mortar in corresponding mortice in bed or side joint or adjacent stones (See Fig. 7.1A).

#### **Jamb**

The part of the wall at the side of an opening.



**Joggle**

A key between the stones by providing a groove in one stone to take a corresponding concealed projection in the edges on the other stone (See Fig. 7.1B).

**Natural Bed**

The planes of stratification that occurs in a sedimentary rocks.

**Parapet**

A solid or pierced guard wall for flat stone terrace or balcony (or a bridge) or a curb wall at the lower part of a pitched roof which is exposed to atmosphere on face back and top (See Fig. 7.1C).

**Quoin**

A quoin is the external angle of wall or building. The term is also applied to stone specially selected and neatly dressed for forming such angle.

**Random**

Random or irregular size and shapes.

**Reveal**

The part of the jamb between the frame and the arris.

**Rubble Masonry**

Masonry built of stones either irregular in shapes as quarried or squared and only hammer dressed and having comparatively thick joints. As far as possible, stones for rubble masonry shall be angular.

**Skewback**

Sloping surface against which the springing of an arch rests.

**Spandrel**

Space between the haunches below the decking level.

**String Course**

A horizontal band, plain or moulded, usually projecting slightly from the face of wall (See Fig. 7.1C).

**Surfacing or Dressing of Stones**

The stones are dressed to have different surfaces as indicated below.

**Template or Bed Block**

A block of stone or concrete bedded on a wall to distribute the pressure from a concentrated load.

**Self Faced Surfaces**

Surfaces of stone slabs used for roofing, flooring, lintels etc. as obtained from quarry.

**Squared Back Surface**

Means the surface shall be dressed back at right angles to the face of the stone.

**Chisel Drafted Margin**

The dressing done with a drafting chisel in narrow strips of width generally 2 to 5 cm. Chisel drafted margin shall be punch dressed.

### **Hammer Dressed Surface**

A hammer dressed stone shall have no sharp and irregular corners and shall have a comparatively even surface so as to fit well in masonry. Hammer dressed stone is also known as hammer faced, quarry faced and rustic faced. The bushing from the general wall face shall not be more than 40 mm on exposed face and 10 mm on faces to be plastered (Fig. 7.2).

### **Rock Faced Surface**

A rock faced stone shall have a minimum of 25 mm wide chisel drafted margin at the four edges, all the edges being in the same plane (Fig. 7.3).

### **Rough Tooled Surface**

A rough tooled surface shall have a series of bands, made by means of a plane chisel 4 to 5 cm wide, more or less parallel to tool marks all over the surface. These marks may be either horizontal, vertical or at an angle of 45° as directed (Fig. 7.4). The edges and corners shall be square and true. The depth or gap between the surface and straight edge, held against the surface shall not be more than 3mm (Rough tooled stones are used where fairly regular plane faces are required for masonry work).

### **Punched Dressed Surface**

A rough surface is further dressed by means of punch chisel to show series of parallel ridges. The depth of gap between the surface and a straight edge held against the surface shall not exceed 3 mm (Fig. 7.5). Punched dressed stones are used where even surfaces are required.

### **Close Picked Surface**

A punched stone is further dressed by means of point chisel so as to obtain a finer surface, ridges or chisel marks left over being very tiny. The depth of gap between the surface and a straight edge kept over the surface shall not exceed 1.5 mm (Fig. 7.6).

### **Fine Tooled Surface**

Close picked surface is further dressed so that all the projections are removed and fairly smooth surface is obtained. The surfaces shall have 3 to 4 lines per centimetre width depending on the degree of hardness of stone and degree of fineness required (Fig. 7.7). This type of dressing is commonly adopted for ashlar work.

### **Polished Surface**

Surfaces having a high gloss finish. Polishing of stones shall be done by rubbing them with suitable abrasive, wetting the surface where necessary with water. Alternatively polishing of stones shall be done by holding them firmly on the top of revolving table to which some abrasive material like sand or carborundum is fed. The final polishing shall be performed by rubber or felt, using oxide of lime (called by trade name as putty powder) as a polishing medium.

### **Moulded**

Cut to profile of a moulding with punched dressed surfaces, unless otherwise specified.

## **7.1 RANDOM RUBBLE STONE MASONRY**

### **7.1.0 Material**

#### **7.1.1 Stone**

The stone shall be of the type specified such as granite, trap, limestone, sand stone, quartzite, etc. and shall be obtained from the quarries, approved by the Engineer-in-Charge. Stone shall be hard, sound, durable and free from weathering decay and defects like cavities, cracks, flaws, sand holes, injurious veins, patches of loose or soft materials and other similar

defects that may adversely affect its strength and appearance. As far as possible stones shall be of uniform colour, quality or texture. Generally stone shall not contain cryptst crystalline silica or chart, mica and other deleterious materials like iron-oxide organic impurities etc. Stones with round surface shall not be used. The compressive strength of common types of stones shall be as per Table 7.1 and the percentage of water absorption shall generally not exceed 5% for stones other than specified in Table 7.1. For laterite this percentage is 12%.

**TABLE 7.1**

<i>Type of stone</i>	<i>Maximum Water Absorption Percentage by weight</i>	<i>Minimum Compressive Strength kg./sq.cm.</i>
Granite	0.5	1000
Basalt	0.5	400
Lime stone (Slab & Tiles)	0.15	200
Sand stone (Slab & Tiles)	2.5	300
Marble	0.40	500
Quartzite	0.40	800
Laterite (Block)	12	35

**Note 1:** Test for compressive strength shall be carried out as laid down in IS 1121 (Part I).

**Note 2:** Test for water absorption shall be carried out as laid down in IS 1124.

### **7.1.2 Size of Stones**

Normally stones used should be small enough to be lifted and placed by hand. Unless otherwise indicated, the length of stones for stone masonry shall not exceed three times the height and the breadth on base shall not be greater than three-fourth of the thickness of wall, or not less than 150 mm. The height of stone for rubble masonry may be upto 300 mm. The selection and grading of stones for rubble masonry is largely done at site and the smaller stones are used in the hearting of wall.

**7.1.3 Random Rubble Masonry** shall be uncoursed or brought to courses as specified (Fig. 7.8 and 7.9). Uncoursed random rubble masonry shall be constructed with stones of sizes as referred to in para 7.0 and shapes picked up random from the stones brought from the approved quarry. Stones having sharp corners or round surfaces shall, however, not be used.

**7.1.4 Random rubble masonry brought to the course** is similar to uncoursed random rubble masonry except that the courses are roughly levelled at intervals varying from 300 mm to 900 mm in height according to the size of stones used.

### **7.1.5 Dressing**

Each stone shall be hammer dressed on the face, the sides and the beds. Hammer dressing shall enable the stones to be laid close to neighbouring stones such that the bushing in the face shall not project more than 40 mm on the exposed face.

(i) **Face stone:** At least 25% stones shall be headers tailing into the work at least 2/3rd the thickness of wall in super structure masonry. Such stones shall not be less than 200 sq. cm in cross sections.

(ii) **Hearting Stones:** The hearting or interior filling of a wall face shall consist of rubble stones not less than 150 mm in any direction, carefully laid, hammered down with a wooden mallet into position and solidly bedded in mortar. The hearting should be laid nearly level with facing and backing.

(iii) **Quoin Stone:** Quoin stone shall be less than 0.03 cum in volume.

(iv) **Jamb stones:** The jambs shall not be made with stones specified for quoins except that the stones which were required to be provided at 1 metre centre to centre on both the exposed faces shall here be provided only on the jamb and the length shall be equal to the thickness of the wall for wall upto 60 cm and a line of headers shall be provided for walls thicker than 60 cm as specified for bond.

### **7.1.5 (A) Courses**

The masonry shall be carried out in regular courses of height not exceeding 50 cm and masonry on any day will not be raised more than 60 cm in height when using mortars having compressive strength less than 20 kg./sq. cm at 28 days and 100 cm when using mortars exceeding this strength.

### **7.1.5 (B) Thickness of Joints**

The joint thickness shall not exceed 30 mm at any point on the face. Chips of the stone and spalls shall be wedged into seating bed of face stones to avoid excessive bed thickness. No pinning shall be allowed to avoid excessive joint thickness.

### **7.1.6 Mortar**

The mortar used for joining shall be as specified.

### **7.1.7 Laying**

Stone shall be laid on their natural bed and shall be solidly bedded full in mortar with close joints, chips of stone spalls be wedged into the work wherever necessary. No dry work or hollow spaces shall be allowed and every stone whether large or small shall be carefully selected to fit snugly the interstices between the large stones. Masonry shall be built breaking joints in all the three directions. Bond stone and headers shall be properly laid into the work and shall be marked by the contractor with white lead paint. The bond stones shall be provided as specified in para 7.1.8. The masonry work in wall shall be carried up true to plumb or to specified batter. Random rubble masonry shall be brought to the level courses at plinth, window sills, lintel and roof levels. Levelling shall be done with concrete comprising of one part of the mortar as used for masonry and two parts of graded stone aggregate of 20 mm nominal size. The masonry in structure shall be carried uniformly. Where the masonry of one part is to be delayed, the work shall be raked back at an angle not steeper than 45°.

#### **7.1.7 (A) Raking out joints**

All the joints on the faces to be pointed or plastered shall be raked out with racking tool to a depth of 20mm while the mortar is still green.

### **7.1.8 Bond Stones**

Though bond stones shall be provided in walls upto 600 mm thickness, a set of two or more bond stones overlapping each other by at least 150 mm shall be provided in a line from face to back. In case of highly absorbent types of stones (porous lime stone and sand stone etc.) the bond stone shall extend about two-third into the wall, as through stones in such walls a set of two or more bond stones overlapping each other by at least 150 mm shall be provided. Each bond stone or a set of bond stones shall be provided for every 0.5 m<sup>2</sup> of the wall surface and shall be provided at 1.5 m to 1.8 m apart clear in every course. In case of highly absorbent types of stones (porous lime stone and sand stone etc.) single piece bond stones may give rise to dampness. For all thicknesses of such walls a set of two or more bond stones overlapping each other by at least 15 cm shall be provided. Length of each such bond stone shall not be less than two-third of the thickness of the wall. Where bond stones of suitable lengths are not available pre-cast cement concrete block of 1:3:6 mix (1 cement : 3 coarse sand: 6 graded stone aggregate 20 mm nominal size) of cross section not less than 225 square centimeters and length equal to the thickness. At least one bond stone or a set of bond stones shall be provided at 1.5 m to 1.8 m apart clear in every course. (Bond stones shall be marked suitably with paint as directed by the Engineer-in-Charge).

### **7.1.9 Quoin and Jamb Stones**

The quoin and jamb stones shall be of selected stones neatly dressed with hammer or chisel to form the required angle. Quoin stones shall not be less than 0.01 cum in volume. Height of quoins and jamb stones shall not be less than 15 cm. Quoins shall be laid header and stretcher alternatively.

### **7.1.10 Joints**

Stones shall be so laid that all joints are fully packed with mortar and chips. Face joints shall not be more than 20 mm thick. The joints shall be struck flush and finished at the time of laying when plastering or pointing is not to be done. For the surfaces to be plastered or pointed, the joints shall be raked to a minimum depth of 20 mm when the mortar is still green.

### **7.1.11 Scaffolding**

Single scaffolding having one set of vertical support shall be allowed. The supports shall be sound and strong, tied together by horizontal pieces, over which the scaffolding planks shall be fixed. The inner end of the horizontal scaffolding member may rest in a hole provided in the masonry. Such holes, however, shall not be allowed in pillars under one metre in width or near the skew back of arches. The holes left in masonry work for supporting scaffolding shall be filled and made good with cement concrete 1 : 3 : 6 (1 cement : 3 coarse sand : 6 stone aggregate 20 mm nominal size).

### **7.1.12 Curing**

Masonry work in cement or composite mortar shall be kept constantly moist on all faces for a minimum period of seven days. In case of masonry with fat lime mortar curing shall commence two days after laying of masonry and shall continue for at least seven days thereafter.

### **7.1.13 Protection**

Green work shall be protected from rain by suitable covering. The work shall also be suitably protected from damage, mortar dropping and rain during construction.

### **7.1.14 Measurements**

**7.1.14.1** The length, height and thickness shall be measured correct to a cm. The thickness of wall shall be measured at joints excluding the bushing. Only specified dimensions shall be allowed; anything extra shall be ignored. The quantity shall be calculated in cubic metre nearest to two places of decimal.

**7.1.14.2** The work under the following categories shall be measured separately.

(i) From foundation to plinth level (level one) :

(a) work in or under water and or liquid mud,

(b) work in or under foul positions.

(i) Above plinth level and upto floor five level.

(ii) Above floor five level to every floor/floors or part thereof.

(iv) Stone masonry in parapet shall be measured together with the corresponding item in the wall of

the storey next below.

**7.1.14.3** No deduction shall be made nor extra payment made for the following :

(i) Ends of dissimilar materials (that is joists, beams, lintels, posts, girders, rafters purlins, trusses, corbels, steps etc.) upto 0.1 sqm in section.

(ii) Openings each upto 0.1 sqm in area. In calculating the area of openings, any separate lintels or sills shall be included alongwith the size of opening but the end portions of the lintels shall be excluded and the extra width of rebated reveals, if any, shall also be excluded. (iii) Wall plates and bed plates, and bearing of chajjas and the like, where the thickness does not exceed 10 cm and the bearing does not extend over the full thickness of the wall.

**Note:** The bearing of floor and roof shall be deducted from wall masonry.

(iv) Drain holes and recesses for cement concrete blocks to embed hold fasts for doors, windows etc.

(v) Building in masonry, iron fixture, pipes upto 300 mm dia, hold fasts of doors and windows etc.

(vi) Forming chases in masonry each upto section of 350 sq cm.

Masonry (excluding fixing brick work) in chimney breasts with smoke or air flues not exceeding 20 sq dm (0.20 sq m) in sectional area shall be measured as solid and no extra payment shall be made for pargetting and coring such flues. Where flues exceed 20 sq dm

(0.20 sq m) sectional area, deduction shall be made for the same and pargetting and coring flues shall be measured in running metres stating size of flues and paid for separately. Aperture for fire place shall not be deducted and no extra payment made for splaying of jambs and throating.

**7.1.14.5** Apertures for fire places shall not be deducted and extra labour shall not be measured for splaying of jambs, throating and making arch to support the opening.

**7.1.14.6 Square or Rectangular Pillars:** These shall be measured as walls, but extra payment shall be allowed for stone work in square or rectangular pillars over the rate for stone work in walls. Rectangular pillar shall mean a detached masonry support rectangular in section, such that its breadth does not exceed two and a half times the thickness.

**7.1.14.7 Circular Pillars (Columns):** These shall be measured as per actual dimensions, but extra payment shall be allowed for stone work in circular pillars over the rate for stone work in walls. The diameter as well as length shall be measured correct to a cm.

**7.1.14.8** Tapered walls shall be measured net, as per actual dimensions and paid for as other walls.

**7.1.14.9 Curved Masonry:** Stone masonry curved on plan to a mean radius exceeding 6 metres shall be measured and included with general stone work. Stone work circular on plan to a mean radius not exceeding 6 metres shall be measured separately and shall include all cuttings and waste and templates. It shall be measured as the mean length of the wall.

#### **7.1.15 Rate**

The rate shall include the cost of materials and labour required for all the operations described above and shall include the following:

- (a) Raking out joints for plastering or pointing done as a separate item, or finishing flush as the work proceeds.
- (b) Preparing tops and sides of existing walls for raising and extending.
- (c) Rough cutting and waste for forming gables cores, skew backs or spandrels of arches, splays at eaves and all rough cutting in the body of walling unless otherwise specified.
- (d) Bond stones or cement concrete bond blocks.
- (e) Leading and making holes for pipes etc.
- (f) Bedding and pointing wall plates, lintels, sills etc. in or on walls, bedding roof tiles and corrugated sheets in or on walls.
- (g) Building in ends of joists, beams, lintels etc.

#### **Note:-**

1. For further detail refer CPWD specification volume 1, Sub Head 7.0
2. For site development works like RR masonry and other related work, the specification for Specific Items will be govern by PWD SOR (Road & Bridge)/MORD.

**Note:-** For further detail refer CPWD specification volume 1, Sub Head 7.0

## **SUB HEAD : 8.0 MARBLE WORK**

### **8.0 GENERAL**

Marble shall be hard, sound, dense and homogeneous in texture with crystalline texture as far as possible. It shall generally be uniform in colour and free from stains, cracks, decay and weathering. Marbles are metamorphic rocks capable of taking polish, formed from the re-crystallization of lime stones or dolomitic lime stones and are distinguished from lime stone by even visibly crystalline nature and no flaggy stratification.

**Note :** Marble is a product of nature hence it is difficult to guarantee uniformity of colour, veining or other characteristics that may be represented in any sample submitted. A sample will indicate only an average of colour, veining and other general texture and specified finish.

### **8.1 CLASSIFICATION**

The marble blocks, slabs and tiles shall be classified broadly in the following two categories:

#### **8.1.1 White Marble**

*Raj Nagar (plain white) Marble:* It shall be plain white marble with coarse grains predominantly showing mica particles giving reflection in light.

#### **8.1.2 Coloured Marble**

##### (i) Plain Black Marble

Black marble sawn along veins locally known as 'Peta Pasu sawing' available at Bhainslana.

##### (ii) Black Zebra Marble

(a) *Bhainslana Black Zebra Marble:* Black marble having grey or white veins available at Bhainslana.

(b) *Kishangarh Black Zebra Marble:* Black marble with grey and/or white veins available at Kishangarh.

(c) *Abu Black Zebra Marble:* Black marble having white patches and streaks available at Abu.

(d) *Narnaul Black Zebra Marbles:* Black marble with thin white veins available at Narnaul.

(e) *Makrana Dhobi Doongri Zebra Marble:* Greyish black marble with white flowery pattern available at Dhobi Doongri.

##### (iii) Green Marble

(a) *Baroda Green Marble:* Dark green marble with flowery pattern available at Baroda.

(b) *Abu Green Marble:* Light green marble with green and/or brown streaks on white ground available at Ambaji.

(c) *Falna Green Marble:* Green marble with prominent yellowish pattern available at Falna.

(d) *Bundi Green Marble:* Green marble with pinkish shades available at Umar, (Bundi).

##### (iv) Grey Marble

(a) *Kumari Grey Marble:* Grey marble having light blue shades available at Makrana.

(b) *Bundi Grey Marble:* Grey Marble with pink or green or black streaks available at Umar (Bundi).

##### (v) Brown Marble

(a) *Bar Brown Marble/Brown Marble* with light and dark brown shades available at Bar.

(b) *Narnaul Brown Marble* Brown marble having teak wood shades available at Narnaul.

#### **8.1.3 Granite Stone**

It shall be of any colour and size as directed by Engineer-in-Charge. Granite shall be plain machinecut and mirror polished. The stone shall be smooth and of even surface without holes or pits.

### **8. SIZES AND TOLERANCES**

The size of marble blocks, slabs and tiles shall be as mentioned in Table 8.1

**TABLE 8.1**

**Sizes of Marble Blocks, Slabs and Tiles**

		<i>Length</i>	<i>Width</i>	<i>Thickness</i>
1.	Blocks	30 to 250	30 to 100	30 to 90
2.	Slabs	70 to 250	30 to 100	2 to 15
3.	Tiles	10 to 60	10 to 60	0.8 to 2.4

**Notes:**

- (1) All dimensions are in centimeter.
- (2) The length and width, of the blocks shall be in multiple of 30 cm.
- (3) Length and width of slab shall be in multiple of 10 cm. and thickness in multiple of 1 cm.
- (4) Tiles shall be square cut and linear dimensions in multiple of 10 cm.
- (5) Only slabs and tiles shall be machine cut and factory made.
- (6) For 8 mm thick tiles, special precautions will be required for fixing them like using special adhesive as per manufacturer's specifications. Such tiles are not suitable for outside veneering work exposed to rains/sun if used in large areas in continuous stretches. For tiles of thickness 20mm and above cramps may be provided if approved by Engineer-in-Charge.

**Tolerance**

The following tolerances shall be allowed in the dimension of blocks, slabs and tiles:  
Tolerance

*Blocks*

- (a) Length + 2 per cent
- (b) Width + 2 per cent
- (c) Thickness + 2 per cent

- (a) Length + 2 per cent
- (b) Width + 2 per cent

- (c) Thickness + 3 per cent

- (a) Linear dimension + 3 per cent
- (b) Thickness + 1 per cent

The sizes other than those mentioned above may be provided as directed by the Engineer-in-Charge and nothing extra shall be payable on this account.

**8.3 PHYSICAL PROPERTIES**

**8.3.1** The physical properties of marble for blocks, slabs and tiles and method of tests are mentioned in Table 8.2

**TABLE 8.2**

**Physical Properties of Marble & Granite**

<i>Characteristic</i>	<b>Marble</b>		<b>Granite</b>	
	<i>Marble Requirements</i>	<i>Method of test</i>	<i>Granite Requirement</i>	<i>Method of test</i>
(1) Moisture absorption after 24 hrs immersion in cold water	Max. 0.4%	IS 1124	Max. 0.50% by weight	IS 1124
(2) Hardness	Min. 3	Mhos scale	—	—
(3) Specific Gravity	Min. 2.5	IS 1122	Min. 2.6	IS 1122



### 8.5.1 Dressing, Cutting and Rubbing

Every marble stone shall be gang saw/machine cut to the required size and shape, chisel dressed machine finished on all beds and joints, so as to be free from any waviness and to give truly vertical horizontal, radial or circular joints as required. The exposed faces and sides of stones forming joints upto 6mm. from the face shall be fine tooled machine cut such that a straight edge laid along the face of the stone is in contact with every point on it. All window sills, tread of steps, counters vanities moulding edges etc. shall be machine cut & polished to give high gloss mirror finish as per direction of Engineer in- Charge. These surfaces shall then be rubbed smooth. All visible angles and edges shall be true square and free from chipping. Beyond the depth of 6 mm from face, the joints shall be dressed with as light splay so that the thickness of joint increases, in an inverted V shape as shown in Fig. below. The surfaces of the stones coming in contact with backing need not be chisel dressed.

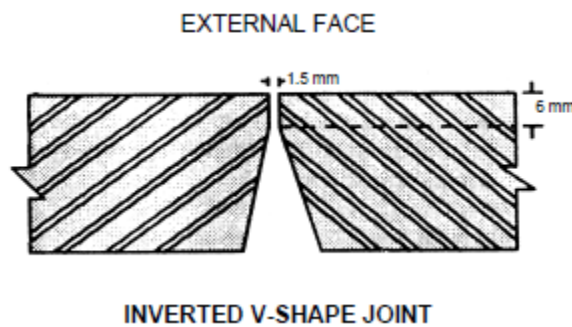

**A sample of dressed and rubbed stone shall be prepared for approval and it shall be kept on work site after being approved by the Engineer-in-charge.**

#### 8.5.11 Measurements

For plain work: Measurements shall be taken correct to a cm in length and breadth and correct to 0.5 cm in thickness.

**8.5.11.1** In the case of radially dressed or circular stone used in the work, the dimensions of the circumscribing rectangle of the dressed stone, shall be measured correct to a centimetre and thickness, correct to 0.5 cm. The cubical contents shall be calculated in cubic decimetre nearest to two places of decimal.

**8.5.11.2** The marble work in arches and domes shall be measured as for plain work, but extra shall be allowed for such work over the rate for plain work.

**8.5.11.3** Sunk or moulded work in marble shall be measured by volume as per plain marble work or work in arches or domes as the case may be on the basis of circumscribed rectangular block of the finished work but extra shall be paid for such work over the rate for plain work for work in arches and domes. For the purpose of extra payment, volume of every stone sunk or moulded shall be considered.

### 8.6 WALL LINING/VENEER WORK

**8.6.1** Unless and otherwise specified in the nomenclature of the item, the marble slabs used for wall lining/veneer work shall be gang saw cut (polished & machine cut) and conform to dimensions given in

Table 8.1 above. Back shall not be polished/ cut in order to ensure a good grip with the hearting of backing. The cut slabs shall be of the thickness as specified with a tolerance permissible under para 8.2 above. The tolerance in wall lining when straight edge of 3 m length is placed should not be more than 2 mm.

#### 8.6.6 Measurements

The length and breadth shall be measured correct to a cm. In case of radially dressed or circular slabs used in the work, the dimensions of the circumscribing rectangles of the

dressed stone used in the work, shall be measured & paid for. The area shall be calculated in sqm nearest to two places of decimal. Marble work in lining upto 4 cm thickness shall be paid by area under veneer work and lining of greater thickness paid by volume under plain marble work.

## **8.7 MARBLE STONE FLOORING AND MARBLE STONE IN RISERS OF STEPS AND SKIRTI**

### **8.7.0 Marble Slab Urinal Partitions**

The partitions shall be of marble slab embedded in the wall. The size and shape of the marbles slab shall be as per direction of Engineer-in-Charge. The finished thickness shall be 18 mm. The specifications for marble/granite stone work, in general, shall be as specified. The marble granite stone shall be cut into slabs of required thickness and shall be one piece. (Fig. 8.4).

#### **8.7.1 Finishing**

The partition of the slab to be embedded in the masonry shall be rough dressed. Dressing and rubbing of the exposed portion of the slab shall be as described. The dressed slab shall be of the thickness as Specified with a tolerance of + 1.5mm. The slab shall be got approved from the Engineer-in-Charge before fixing.

**8.7.2 Fixing** shall be as specified except that the recess shall be 7.5 cm wide. Fixing shall be done by cutting chase with chase cutter/fine tools in a recess of 7.5 cm X 7.5 cm filled with cement concrete 1:2:4 (1 cement : 2 coarse sand : 4 graded stone aggregate 6mm nominal size). Fixing can also be done by epoxy grout in a chase of 2.0 X 7.5 cm as per direction of Engineer-in-Charge.

**8.7.3 Measurement** shall be as per para 8.6.6.

**Note:- For further detail refer CPWD specification volume 1, Sub Head 8.0**

**SUB HEAD : 9.0**  
**WOOD WORK AND P.V.C. WORK**

**9.3.4 Measurements**

Wood work wrought, framed and fixed shall be measured for finished dimension without any allowance for the wastage or for dimensions beyond specified dimension. However, in case of members having mouldings, roundings or rebates and members of circular or varying sections, finished dimensions shall be taken as the sides of the smallest square or rectangle from which such a section can be cut. Length of each member shall be measured over all to the nearest cm so as to include projection for tenons. Width and thickness shall be measured to the nearest mm and the quantity shall be worked out in unit of upto three places of decimal.

**9.4 FALSE CEILING AND PARTITION FRAMES**

This work shall be done as specified in 9.3 except that the scantlings need not be planed unless otherwise specified.

**9.7 FLUSH DOOR SHUTTERS**

**9.7.0** Flush door shutters shall have a solid core and may be of the decorative or non-decorative (Paintable type as per IS 2202 (Part I). Nominal thickness of shutters may be 25, 30 or 35 mm. Thickness and type of shutters shall be as specified.

**9.7.1** Width and height of the shutters shall be as shown in the drawings or as indicated by the Engineer-in-Charge. All four edges of the shutters shall be square. The shutter shall be free from twist or warp in its plane. The moisture content in timbers used in the manufacture of flush door shutters shall be not more than 12 per cent when tested according to IS 1708.

**9.7.2 Core**

The core of the flush door shutters shall be a block board having wooden strips held in a frame constructed of stiles and rails. Each stile and rail shall be a single piece without any joint. The width of the stiles and rails including lipping, where provided shall not be less than 45 mm and not more than 75mm. The width of each wooden strip shall not exceed 30 mm. Stiles, rails and wooden strips forming the core of a shutter shall be of equal and uniform thickness. Wooden strips shall be parallel to the stiles. End joints of the pieces of wooden strips of small lengths shall be staggered. In a shutter, stiles and rails shall be of one species of timber. Wooden strips shall also be of one species only but it may or may not be of the same species as that of the stiles and rails. Any species of timber may be used for core of flush door. However, any non-coniferous (Hard wood) timber shall be used for stiles, rails and lipping

**9.7.3 Face Panel**

The face panel shall be formed by gluing, by the hot-press process on both faces of the core, either plywood or cross-bands and face veneers. The thickness of the cross bands as such or in the ply wood shall be between 1.0 mm and 3.0 mm. The thickness of the face veneers as such or in the plywood shall be between 0.5 mm and 1.5 mm for commercial veneers and between 0.4 mm and 1.0 mm for Decorative veneers, provided that the combined thickness of both is not less than 2.2 mm. The direction of the veneers adjacent to the core shall be at right angles to the direction of the wooden strips. Finished faces shall be sanded to smooth even texture. Commercial face veneers shall conform to marine grade plywood and decorative face veneers shall conform to type I decorative plywood in IS 1328.

## **9.8 WIRE GAUZE FLY PROOF SHUTTERS**

**9.8.0** Specified timber shall be used, and it shall be sawn in the direction of the grains. Sawing shall be truly straight and square. The timber shall be planed smooth and accurate to the full dimensions, rebates, roundings and mouldings as shown in the drawings made, before assembly. Patching or plugging of any kind shall not be permitted except as provided.

### **9.8.2 Wire Gauze**

This shall be unless specified otherwise conform to para 8.2.7 and 8.6.4.5. The wire gauze shall be bent at right angles in the rebates of stiles and rails, turned back and fixed tight with blue tacks at about 75 mm centres, fixed alternately in the two faces of the rebates. Over this, wooden beading shall be fixed with brads or small screws at about 75 mm centres.

## **9.13 HOLD FASTS**

**9.13.0** These shall be made from mild steel flat 40 × 5 mm size conforming to IS 7196 without any burrs or dents. 5 cm length of M.S. flat at one end shall be bent at right angle and one hole 11 mm dia shall be made in it for fixing to wooden frame with 10 mm dia nut bolt. The bolt head shall be sunk into the wooden frame, 10 mm deep and plugged with wooden plug. At the other end 10 cm length of the hold fast flat shall be forked and bent of length as specified at right angle in opposite direction and embedded in cement concrete block of size 30 x 10 x 15 cm of mix 1:3:6 (1 cement : 3 coarse sand : 6 graded stone aggregate, 20 mm nominal size) or as specified

### **9.15.7 Sliding Door Bolts (Aldrops) (Fig. 8.7)**

**9.15.7.1** These shall be of mild steel, cast brass, aluminum or as specified, and shall be capable of smooth sliding action.

**9.15.7.4 Aluminum Sliding Door Bolts :** These shall be made of aluminum alloy and shall generally conform to IS 2681. Aluminum sliding door bolts shall be anodized. All screw holes shall be counter sunk to suit the counter sunk head of screws of specified sizes. All edges and corners shall be finished smooth. In case of single leaf door, when iron socket plate or a brass or aluminum fixing bolts (or sliding door bolt) cannot be fixed, hole of suitable size shall be drilled in the door frame and an iron or brass plate cut to hape shall be fixed at the face of the hole. The leading dimensions of the sliding door bolts are illustrated.

### **9.15.8 Tower Bolts (Fig. 9.8)**

**9.15.8.0** These shall generally conform to IS 204 (Part. I) & IS 204 (Part. II). Tower bolts shall be well made and shall be free from defects. The bolts shall be finished to the correct shape and shall have a smooth action. All tower bolts made with sheet of 1.2 mm thickness and above shall have counter sunk screw holes to suit counter sunk head of wood screws. All sharp edges and corners shall be removed and finished smooth

### **9.15.10 Pull Bolt Locks**

**9.15.10.1** These shall be of M.S. cast brass or aluminium as specified. M.S. pull bolt locks shall be copper oxidized (black finish) or as specified.

**9.15.10.2** Brass pull bolt locks shall be finished bright, chromium plated or oxidised as specified. Aluminium pull bolt locks shall be anodised and the anodic coating shall not be less than grade. A.C. 10 of IS 1868. The bolt shall be 10 mm in diameter and the fixing plate 3 mm thick. The stop block shall be screwed to the fixing plate by a small ball and spring over which the bolt shall slide.

**9.15.10.3** The fixing plate shall have four holes for fixing it to the door leaf, two of which shall be square to receive 6 mm dia. bolts with round heads, the remaining two shall receive machine screwed with locknuts. The receiving plate shall be of the same width and

thickness as the fixing plate and shall have 3 counter sunk holes. Where the bolt slides into wooden members, like the chowkhat, which have a rebate, the receiving plate shall also be correspondingly shaped so as to fit into the rebate. The screws and bolts shall have the same finish as the main bolt. The leading dimensions of pull bolt locks are given in the drawing. The denominating size of the pull bolt locks shall be length of the fixing plate between guides plus the thickness of the guides.

### 9.15.19 Door Handles (Doors and Windows)

**9.15.19.1** These should generally conform to IS 208. The door handles shall be well made and free from defects. These shall be finished correct to shape and dimensions. All edges and corners shall be removed and finished smooth so as to facilitate easy handling. Cast handle shall be free from casting defects. Where the grip portion of the handle is joined with the base piece by mechanical means, the arrangement shall be such that the assembled handle shall have adequate strength comparable to that of integrally cast type handles.

### Floor Door Stopper

**9.15.20.1** The floor door stopper shall conform to IS 1823. This shall be made of cast brass of overall size as specified and shall have rubber cushion. The shape and pattern of stopper shall be approved by the Engineer-in-Charge. It shall be of brass finished bright, chromium plated or oxidised or as specified. The size of floor stopper shall be determined by the length of its plate. It shall be well made and shall have four counter sunk holes for fixing the door stoppers to the floor by means of wood screws. The body for housing of the door stopper shall be cast in one piece and it shall be fixed to the cover plate by means of brass or mild steel screws and cover plate shall be of casting or of sheet metal. The spring shall be fixed firmly to the pin. Tongue which would be pressed while closing or opening of the door shall be connected to the lower part by means of copper pin. On the extreme end a rubber piece shall be attached to absorb shock. All parts of the door stopper shall be of good workmanship and finish, burrs and sharp edges removed. It shall be free from surface and casting defects. Aluminium stopper shall be anodised and anodic film shall not be less than grade AC-10 of IS 1868.

**Note:- For further detail refer CPWD specification volume 1, Sub Head 9.0**

**Requirements for Rubber for Use in Floor Door Stoppers**

<i>Particulars</i>	<i>Requirements</i>	<i>Testing Procedure</i>
Relative density Max.	1.3	IS 3400 (Part IX)
Hardness	60 + 5	IS 3400 (Part 2)
Ageing for 24 hours at 100° ± 1°C	(a) Change in initial hardness	IS 3400 (Part II)
	(b) Shall not develop brittleness + 5, - 0	-do-

## SLIDING DOOR BOLTS

Sub Head : Wood Work and PVC Work  
Clause : 9.15.7

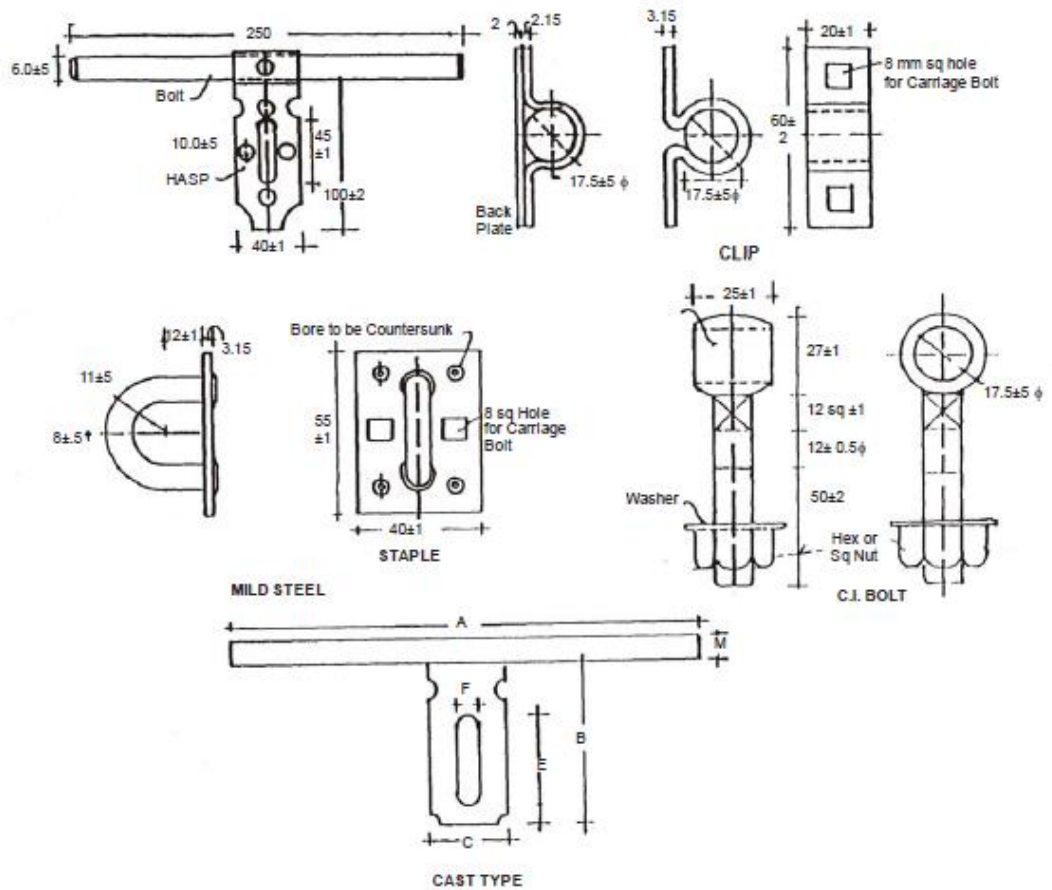

### DIMENSIONS

Size	A	B	C	E	F	M	Screw Designation No.
250	250 ± 2	100 ± 2	45 ± 1	55 ± 1	15 ± 1	16.0 ± 0.5	Ø
300	300 ± 2	100 ± 2	45 ± 1	55 ± 1	15 ± 1	16.0 ± 0.5	Ø

Drawing not to Scale  
All dimensions are in mm

Fig. 9.7 : Sliding Door Bolts

**PULL BOLT LOCKS**

**Sub Head : Wood Work and PVC Work  
Clause : 9.15.10**

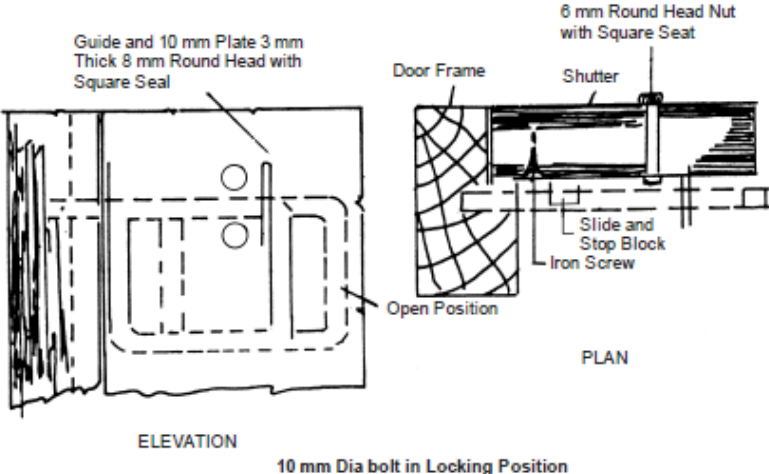

Drawing not to Scale

**Fig. 9.9 : Pull Bolt Locks**

## **SUB HEAD : 10.0 STEEL WORK**

### **10.0 DEFINITIONS/ TERMINOLOGY**

#### **Bead**

A single run of weld metal deposited on surface.

#### **Butt Weld**

A weld in which the weld metal lies substantially within the extension of the planes and the surfaces *on* the parts joined.

#### **Crater**

A depression left in weld metal where the *arc* was broken or the flame was removed.

#### **End Crater**

A crater at the end of a weld or at the end of a joint.

#### **Fillet Weld**

A weld of approximately triangular cross-section joining two surfaces approximately at the right angles to each other in a lap joint, tee joint or corner joint. It is of two types:

- (1) Continuous
- (2) Intermittent.

#### **Fusion Welding**

Any welding process in which the weld is made between metals in a state of fusion without hammering or pressure.

#### **Non- fusion Welding**

A term applied to the deposition, by the Oxy-Acetylene process of filler metal on parent metal without fusion of the latter.

#### *Oxy-Acetylene Pressure Welding*

Pressure welding in which any Oxy-Acetylene flame is used to make the surface to be united plastic. No filler metal is used.

#### **Run**

The metal deposited during one passage of the electrode or blow pipe in the making of a joint.

#### **Throat thickness**

See Fig. 10.1.

#### **Weld**

A union between two pieces of metal at faces rendered plastic or liquid by heat or pressure, or both, Filler metal may be used to effect the union.

### **10.1 MATERIALS**

#### **Micro-Alloying Elements**

Elements such as niobium, boron, vanadium and titanium added singly or in combination to obtain higher strength to weight ratio and better toughness, formability and weldability as compared to unalloyed steel of similar strength level.

#### **Weldability**

A metallic substance is considered to be weldable by a given process and for the given purpose, when metallic continuity to a stated degree can be obtained by welding using a suitable procedure, so that the joints comply with the requirements specified in regard to both their local properties and their influence on the construction of which they form a part.

#### **Controlled Rolling**

A hot rolling process in which the temperature of the steel and its reduction ratio are controlled, particularly during the final rolling passes, in order to achieve fine grain micro structure and optimum mechanical properties.

#### **Normalizing Rolling**

A hot rolling process in which the final rolling passes are carried out at a suitable higher temperature, followed by cooling in natural air to a temperature below the transformation



temperature, in order to produce a structure, analogous to that obtained by a separate normalizing treatment of hot rolled product.

### **10.1.1 Steel**

**10.1.1.1 Supply of Material :** General requirements relating to supply of structural steel shall conform

to IS 8910.

**10.1.1.2 Grades :** There shall be nine grades of steel as given in Tables 10.1 and 10.2. While placing the order the steel should be designated by 'Designation' (See Table 10.1 and 10.2).

**10.1.1.3 Manufacture :** The processes used in the steel making and further hot rolling into steel plates, strips, sections, flats, bars, etc., are left to the discretion of the manufacturer/supplier. If required, secondary refining may follow steel making, as also normalizing rolling/controlled rolling during manufacturing of sections or as per the agreement between the purchaser and the manufacturer/supplier.

#### **10.1.1.4 Freedom from Defects**

**10.1.1.4.1** All finished materials shall be well and cleanly rolled to the dimensions, sections and masses specified. The finished material shall be reasonably free from surface flaws; laminations; rough/jagged and imperfect edges and all other harmful defects.

**10.1.1.4.2** Minor surface defects may be removed by the manufacturer/supplier by grinding provided the thickness is not reduced locally by more than 4 percent below the minimum specified thickness. Reduction in thickness by grinding greater than 4 percent but not exceeding 7 percent may be made subject to mutual agreement between the purchaser and manufacturer/supplier.

**10.1.1.4.3** Subject to agreement with the purchaser, surface defects which cannot be dealt with as in 10.1.1.4.2 may be repaired by chipping or grinding followed by welding and inspection by a mutually agreed procedure such that :

(a) After complete removal of the defects and before welding, the thickness of the item is not to be reduced by more than 20 percent at any place.

(b) Welding is carried out by procedure APPROVED by competent authority with approved electrodes and the welding is ground smooth to the correct nominal thickness; and

(c) Subsequent to the finish grinding, the item may be required to be normalized or otherwise heat treated

at the purchaser's discretion.

**10.1.1.4.4** Welding as mentioned in 10.1.1.4.3 is not permissible for grade designation E 250 material.

**10.1.1.5 Chemical Composition :** Ladle Analysis the ladle analysis of the steel, when carried out by the method specified in the relevant part of IS 228 or any other established instrumental /chemical method, shall be as given in Table 10.1. In case of dispute, the procedure given in IS 228 and its relevant parts shall be the referee method and where test methods are not specified shall be as agreed to between the purchaser and the manufacturer/supplier.

### **10.1.2 Rivets**

Rivets shall be made from rivet bars of mild steel as per IS 1148.

### **10.1.3 Bolts**

These are of two types namely turned and fitted bolts and black bolts. Turned & fitted bolts are turned to exact diameter in automatic lathe. For these bolts, whether reamed or drilled bolts, the same unit stresses are allowed as for rivets. In case of black bolts which are not finished to exact sizes, a lower working stress other than for turned bolts is adopted. They shall conform to IS 1367 – Technical supply conditions for threaded steel fasteners.

### **10.1.4 Electrodes**

The electrodes required for metal arc welding shall be covered electrodes and shall conform to IS 814.

## **10.2 STEEL WORK IN SINGLE SECTION FIXED INDEPENDENTLY WITH CONNECTING PLATE**

**10.2.0** The steel work in single section of R.S. joists, flats, Tees Angles fixed independently with or without connecting plate, is described in these clauses.

**10.2.1 Fabrication**

The steel sections as specified shall be straightened and cut square to correct lengths and measured with a steel tape. The cut ends exposed to view shall be finished smooth. No two pieces shall be welded or otherwise jointed to make up the required length of member. All straightening and shaping to form, shall be done by pressure. Bending or cutting shall be carried out in such a manner as not to impair the strength of the metal.

**10.2.2 Painting**

All surfaces which are to be painted, oiled or otherwise treated shall be dry and thoroughly cleaned to remove all loose scale and loose rust. Surfaces not in contact but inaccessible after shop assembly, shall receive the full specified protective treatment before assembly. This does not apply to the interior of sealed hollow sections. Part to be encased in concrete shall not be painted or oiled. A priming coat of approved steel primer such as Red Oxide/Zinc Chromate primer conforming to IS 2074 shall be applied before any member of steel structure are placed in position or taken out of workshop.

**10.2.3 Erection**

Steel work shall be hoisted and placed in position carefully without any damage to itself and other building work and injury to workmen. Where necessary mechanical appliances such as lifting tackle winch etc. shall be used. The suitability and capacity of all plant and equipment used for erection shall

be upto the satisfaction of the Engineer-in-charge.

**10.2.4 Measurements**

The work as fixed in place shall be measured in running metres correct to a millimetre and weights calculated on the basis of standard tables correct to the nearest kilogram. The standard weight of steel sections shall conform to IS 808 with tolerance in sizes as per IS 1852. Tolerance in weight is given in Table 10.3. Steel sections shall be acceptable within tolerance limits. Payment for steel sections shall be made as per actual weight within tolerances. Sections having weight on higher side than permissible tolerance, may be acceptable but payment shall be made on the basis of standard weight only. Steel sections having weight variations lower side than permissible variation shall not be acceptable. Unless otherwise specified, weight of cleats, brackets, packing pieces, bolts, nuts, washers, distance pieces, separators, diaphragm gussets (taking overall square dimension) fish plates, etc. shall be added to the weight of respective items. In riveted work allowance is to be made for weight of rivet heads. Unless otherwise specified an addition of 2.5% of the weight of structure shall be made for shop and site rivet heads in riveted steel structures. No deduction shall be made for rivet/ or bolt holes (excluding holes for anchor or holding down bolts). Deduction in case of rivet or bolt hole shall however be made if its area exceeds 0.02 sqm. The weight of steel sheets, plates and strips shall be taken from relevant Indian standards based on 7.85 Kg/m<sup>2</sup> for every millimetre sheet thickness. For rolled sections, steel rods and steel strips, weight given in relevant Indian Standards shall be used.

**10.2.5 Rate**

Rate includes the cost of labour and materials required for all the operations described above.

**10.3 STEEL WORK IN BUILT UP SECTIONS (RIVETED AND BOLTED)**

The steel work in built up section (Riveted and bolted) such as trusses, framed work etc. is specified in this clause.

**10.3.1 Laying Out**

A figure of the steel structure to be fabricated shall be drawn on a level platform to full scale. This may be done in full or in parts, as shown on drawings or as directed by the Engineer-in-Charge. Steel tape shall be used for measurements.

**10.3.2 Fabrication**

Fabrication shall generally be done as specified in IS 800. In major works or where so specified, shop drawings giving complete information for the fabrication of the component

parts of the structure including the location, type, size, length and details of rivets, bolts or welds, shall be prepared in advance of the actual fabrication and approved by the Engineer-in-charge. The drawings shall indicate the shop and field rivets, bolts and welds. The steel members shall be distinctly marked or stenciled with paint with the identification marks as given in the shop drawings. Great accuracy shall be observed in the fabrication of various members, so that these can be assembled without being unduly packed, strained or forced into position and when built up, shall be true and free from twist, kinks, buckles or open joints. Wooden or metal sheet templates shall be made to correspond to each member, and position of rivet holes shall be marked accurately on them and holes drilled. The templates shall then be laid on the steel members, and holes for riveting and bolting marked on them. The ends of the steel members shall also be marked for cutting as per required dimensions. The base of steel columns and the positions of anchor bolts shall be carefully set out at the required location.

**10.3.2.1** The steel section shall be straight or to be straightened or flattened by pressure unless required to be of curvilinear form and shall be free from twists. These shall be cut square either by shearing or sawing to correct length and measured by steel tape. No tow pieces shall be welded or joined to make up for the required length of member.

**10.3.2.2 Making Holes :** Holes through more than one thickness of materials for members, such as compound stanchion and girder flanges shall, where possible, be drilled after the members are assembled and tightly clamped or bolted together. Punching may be permitted before assembly, provided the holes are punched 3mm less in diameter than the required size and reamed after assembly to the full diameter. The thickness of material punched shall be not greater than 16 mm.

#### ***Rivet Holes***

The diameter for rivets and black bolts holes shall be taken as the nominal diameter of a rivet/ black bolts plus 1.5 mm for rivets/ bolts of nominal diameter less than or equal to 25 mm” and 2.0 mm for rivets of nominal diameter exceeding 25 mm, unless specified otherwise. Holes for turned and fitted bolts shall be drilled or reamed large by 0.2 to 8 mm depending upon the dia. of bolts. Holes shall have their axis perpendicular to the surface bored through. The drilling or reaming shall be free from burrs, and the holes shall be clean and accurate. Holes for rivets and bolts shall not be formed by gas cutting process. Holes for counter sunk bolts shall be made in such a manner that their heads sit flush with the surface after fixing.

**10.3.2.3 Assembly :** Before making holes in individual members, for fabrication and steel work intended to be riveted or bolted together shall be assembled and clamped properly and tightly so as to ensure close abutting, or lapping of the surfaces of the different members. All stiffeners shall be fixed (or placed) tightly both at top and bottom without being drawn or caulked. The abutting joints shall be cut or dressed true and straight, and fitted close together. Web plates of girders, which have no cover flange plates, shall have their ends flush with the tops of angles unless otherwise required. The web plate when spliced, shall have clearance of not more than 5mm. The erection clearance of cleated ends of members connecting steel to steel shall preferably be not greater than 1.5 mm. The erection clearance at the ends of beams without web cleats shall not be more than 3 mm at each end but where for practical reasons, greater clearance is necessary, seating designed suitably shall be provided. Column splices and butt joints of struts and compression members *requiring* contact for stress transmission shall be accurately machined and close butted over the whole section. In column caps and bases, the ends of shafts together with the attached gussets, angles, channels etc. after riveting together shall be accurately machined so that the parts connected, butt against each other over the entire surfaces of contact. Connecting angles or channels shall be fabricated and placed in position with great accuracy so that they are not unduly reduced in thickness by machining. The ends of all bearing stiffeners shall be machined or grounded to fit tightly both at top and bottom.

**10.3.2.4 Riveting :** Rivets shall be used, where slip under load has to be avoided.

*Preliminaries before Riveting:-* Members to be riveted shall have all parts firmly placed and held together before and during riveting, and special care shall be taken in this respect for all single riveted connections. For multiple riveted connections, a service bolt shall be provided in every third or fourth hole.

#### *Process of Riveting*

The riveting shall be carried out by using machines of the steady pressure type. However, where such facilities are not available hand riveting may be permitted by the Engineer-in-charge. The rivets shall be heated red hot, care being taken to control the temperature of heating so as not to burn the steel. Rivets of diameter less than 10mm may be driven cold. Rivets shall be finished neat with heads full and of equal size. The heads shall be central on shanks and shall grip the assembled members firmly. All loose, burnt, or badly formed rivets with eccentric or deficient heads shall be cut out and replaced. In cutting out rivets, care shall be taken so as not to injure the assembled members. Caulking and recapping shall not be permitted. For testing rivets, a hammer weighing approx. 0.25 kg shall be used and both heads of the rivet (Specially the machine head) shall be tapped. When so tested, the rivets shall not give a hollow sound and a jar where so specified, other tests shall be carried out to ensure the soundness of rivets. All rivets heads shall be painted with approved steel primer paint within a week of their fixing.

**10.3.2.5 Bolting :** The nominal length of the bolt shall be the distance from the underside of the head to the further end of the shank. The nominal diameter of the bolt shall be the diameter at the shank above the screwed threads. Bolts, nuts and washers shall be thoroughly cleaned and dipped in double boiled linseed oil, before use. All bolts heads and nuts shall be hexagonal unless specified otherwise. The screwed threads shall conform to IS 1363 and the threaded surface shall not be tapered. The bolts shall be of such length as to project at least two clear threads beyond the nuts when fixed in position, and these shall fit in the holes without any shake. The nuts shall fit in the threaded ends of bolts properly. Where necessary, washers shall be tapered or otherwise suitably shaped to give the heads and nuts of bolts a satisfactory bearing. The threaded portion of each bolt shall project through the nut at least two thread. In all cases where the full bearing area of the bolt is to be developed, the bolt shall be provided with a washer of sufficient thickness under the nuts to avoid any threaded portion of the bolt being within the thickness of the parts bolted together. Where there is a risk of the nuts being removed or becoming loose due to vibrations or reversal of stresses, these shall be secured from slackening by the use of lock nut, spring washers as directed by the Engineer-in-charge.

#### **10.3.3 Erection**

**10.3.3.0** Steel members shall be hoisted and erected in position carefully, without any damage to itself, other structures and equipment and injury to workmen. The method of hoisting and erection proposed to be adopted by the contractor shall be got approved from the Engineer-in-charge in advance. The contractor however shall be fully responsible for the work being carried out in a safe and proper manner without unduly stressing the various members and proper equipment such as derricks, lifting tackles, winches, ropes etc. shall be used.

**10.3.3.1** The work of erection may be done in suitable units as may be directed by the Engineer-in-charge. Fabricated members shall be lifted at such points so as to avoid deformation or excessive stress in members. The structure or part of it placed in position shall be secured against over-turning or collapse by suitable means. During execution, the steel members shall be securely bolted or otherwise fastened when necessary temporarily braced to provide for all loads including those due to erection equipments and its operation to be carried safely by structure during erection. The steel members shall be placed in proper position as per approved drawing, final riveting or permanent bolting shall be done only after proper alignment has been checked and confirmed. **10.3.3.2** Trusses shall be lifted only at nodes. The trusses above 10 m in span shall not be lifted by slinging at two mid points of rafters, which shall be temporary braced by a wooden member of a suitable section. After the trusses are placed in position, purlins and wind bracings shall be fixed as soon as

possible. The end of the truss which faces the prevailing winds shall be fixed with holding down bolts, and the other end kept free to move. In case of trusses of spans upto 10m the free end of the truss shall be laid on lead sheet or steel plate as per design, and the holes for holding down bolts shall be made in the form of oblong slots so as to permit the free movements of the truss end. For larger spans the truss shall be provided with proper bearing as per design. **10.3.3.3** Columns and stanchions shall be erected truly vertical with the necessary cross bracing etc. and the base shall be properly fixed with the foundation concrete by means of anchor bolts etc. as per drawing.

**10.3.3.4** Anchor bolts to be placed in the concrete foundation should be held in position with a wooden template. At the time of concreting anchor bolt locations shall be provided with suitable timber mould or pipe sleeve to allow for adjustment which shall be removed after initial setting of concrete. The spaces left around anchor bolts shall be linked to a stopping channel in the concrete leading to the side of the pedestal and on the underside of the base plate to allow the spaces being grouted up after the base plate is fixed in the position along with the column footing. Grouting shall be of cement mortar 1:3 (1 cement: 3 coarse sand) or as specified.

**10.3.3.5 Bedding of Column, Stanchions etc.:-** Bedding shall not be carried out until the steel work has been finally levelled, plumbed and connected together. The stanchion shall be supported on steel wedges and adjusted to make the column plumb. For multistoreyed buildings, the bedding shall not be done until sufficient number of bottom lengths of stanchions have been properly lined, levelled and plumbed and sufficient floor beams are fixed in position. The base plates shall be wedged clear of the bases by M.S. wedges and adjusted where necessary to plumb the columns. The gaps under the base plate may be made upto 25 mm which shall be pressure grouted with cement grouts. With small columns, if permitted by the Engineer-in-charge, the column base shall be floated on a thick cement grout on the concrete pedestal. The anchor bolt holes in the base plate may be made about 10 to 15 mm larger than the bolts. In such cases suitable washers shall be provided.

#### **10.3.4 Painting**

Before the members of the steel structure are placed in position or taken out of the workshop these shall be painted as specified in 10.2.2.

#### **10.3.5 Measurements**

The work as fixed in position shall be measured in running metres correct to a millimeter and their weight calculated on the basis of standard tables correct to the nearest kilogram. The standard weight of steel sections shall conform to IS 808 with tolerance in sizes as per IS 1852. Tolerance in weight is given in Table 10.3. Steel sections shall be acceptable within tolerance limits. Payment for steel sections shall be made as per actual weight within tolerances. Sections having weight on higher side than permissible tolerance, may be acceptable but payment shall be made on the basis of standard weight only. Steel sections having weight variations lower than permissible variation shall not be acceptable. Unless otherwise specified. Weight of cleats, brackets, packing pieces, bolts nuts, washers, distance pieces, separators diaphragm gussets (taking overall square dimensions) fish plates etc. shall be added to the weight of respective items. No deductions shall be made for skew cuts. In riveted work, allowance is to be made for weight of rivet heads. Unless otherwise specified and addition of 2.5% of the weight of structure shall be made for shop and site rivet heads in riveted steel structures. No deduction shall be made for rivet/ or bolt holes (excluding holes for anchor or holding down bolts). Deduction in case of rivet or bolt hole shall, however, be made if its area exceeds 0.02 m<sup>2</sup>. The weight of steel sheet and strips shall be taken from relevant Indian Standards based on 7.85 kg/m<sup>2</sup> for every millimeter sheet thickness. For rolled sections, steel rods and steel strips, weight given in relevant Indian Standards shall be used.

#### **10.3.6 Rate**

The rate shall include the cost of all materials and labour involved in all the operation described above.

### **10.4 STEEL WORK IN BUILT UP SECTION (WELDED)**

**10.4.0** The steel work in built up sections (welded) such as in trusses, form work etc. is specified in this clause.

**10.4.1 Laying out**

It shall be as specified in 10.3.1.

**10.4.2 Fabrication**

**10.4.2.1** Straightening, shaping to form, cutting and assembling, shall be as per 10.3.2 as far as applicable, except that the words “riveted or bolted” shall be read as “welded” and holes shall only be used for the bolts used for temporary fastening as shown in drawings.

**10.4.2.2 Welding :** Welding shall generally be done by electric arc process as per IS 816 and IS 823. The electric arc method is usually adopted and is economical. Where electricity for public is not available generators shall be arranged by the contractor at his own cost unless otherwise specified. Gas welding shall only be resorted to using oxyacetylene flame with specific approval of the Engineer-in-charge. Gas welding shall not be permitted for structural steel work Gas welding required heating of the members to be welded along with the welding rod and is likely to create temperature stresses in the welded members. Precautions shall therefore be taken to avoid distortion of the members due to these temperature stresses. The work shall be done as shown in the shop drawings which should clearly indicate various details of the joint to be welded, type of welds, shop and site welds as well as the types of electrodes to be used. Symbol for welding on plans and shops drawings shall be according to IS 813. As far as possible every efforts shall be made to limit the welding that must be done after the structure is erected so as to avoid the improper welding that is likely to be done due to heights and difficult positions on scaffolding etc. apart from the aspect of economy. The maximum dia of electrodes for welding work shall be as per IS 814. Joint surfaces which are to be welded together shall be free from loose mill scale, rust, paint, grease or other foreign matter, which adversely affect the quality of weld and workmanship.

**10.4.2.3 Precautions :** All operation connected with welding and cutting equipment shall conform to the safety requirements given in IS 818 for safety requirements and Health provision in Electric and gas welding and cutting operations.

**10.4.2.4** Operation, Workmanship and process of Welding is described in Appendix B,

**10.4.2.5** Inspection and testing of welds shall be as per IS 822.

**10.4.2.6 Assembly :** Before welding is commenced, the members to be welded shall first be brought together and firmly clamped or tack welded to be held in position. This temporary connection has to be strong enough to hold the parts accurately in place without any disturbance. Tack welds located in places where final welds will be made later shall conform to the final weld in quality and shall be cleaned off slag before final weld is made.

**10.4.2.7 Erection :** The specification shall be as described in 10.3.3 except that while erecting a welded structure adequate means shall be employed for temporary fastening the members together and bracing the frame work until the joints are welded. Such means shall consists of applying of erection bolts, tack welding or other positive devices imparting sufficient strength and stiffness to resist all temporary loads and lateral forces including wind. Owing to the small number of bolts ordinarily employed for joints which are to be welded, the temporary support of heavy girders carrying columns shall be specially attended. Different members which shall be fillet welded, shall be brought into as close contact as possible. The gap due to faulty workmanship or incorrect fit if any shall not exceed. 1.5 mm if gap exceeds 1.5 mm or more occurs locally the size of fillet weld shall be increased at such position by an amount equal to the width of the gap.

**10.4.2.8 Painting :** Before the member of the steel structures are placed in position or taken out of the workshop these shall be painted as specified in para 10.2.2.

**10.4.3 Measurements**

The mode of measurements shall be the same as specified in 10.2.4 except that weight of welding material shall not be added in the weight of members for payment and nothing extra shall be paid for making and filling holes for temporary fastening of members during erection before welding.

#### **10.4.4 Rate**

The rate shall include the cost of all labour and materials involved in all the operations described above.

#### **10.5 COLLAPSIBLE STEEL GATES**

**10.5.0** These shall be of approved manufacture and shall be fabricated from the mild steel sections.

**10.5.1** The gates shall consist of double or single collapsible gate depending on the size of the opening. These shall consist of vertical double channels each 20 x 10 x 2 mm. at 10 cm. centre to centre braced with flat iron diagonals 20 x 5 mm and top and bottom rails of T-iron 40 x 40 x 6 mm @ 3.5 kg/m with 40 mm dia. ball bearings in every fourth double channel, unless otherwise specified. Wherever collapsible gate is not provided within the opening and fixed along the outer wall surface, T- iron at the top may be replaced by flat iron 40 x 10 mm. The collapsible gate shall be provided with necessary bolts and nuts, locking arrangement, stoppers and handles. Any special fittings like spring, catches and locks, shall be so specified in the description of item where so required. The gate shall open and close smoothly and easily.

#### **10.5.2 Fixing**

T- iron rails shall be fixed to the floor and to the Lintel at top by means of anchor bolts embedded in cement concrete of floor and lintel. The anchor bolts shall be placed approximately at 45 cm centres alternatively in the two flanges of the T- iron. The bottom runner (T- iron) shall be embedded in the floor and proper groove shall be formed along the runner for the purpose. The collapsible shutter shall be fixed at sides by fixing the end double channel with T-iron rails and also by hold- fasts bolted to the end double channel and fixed in masonry of the side walls on the other side. In case the collapsible shutter is not required to reach the lintel, beam or slab level, a Tee-section suitably designed may be fixed at the top, embedded in masonry and provided with necessary clamps and roller arrangement at the top. All the adjoining work damaged in fixing of gate shall be made good to match the existing work, without any extra cost.

#### **10.5.3 Painting**

All the members of the collapsible gate including T-iron shall be thoroughly cleaned off rust, scales, dust etc. and given a priming coat of approved steel primer conforming to IS 2074 before fixing them in position.

#### **10.5.4 Measurements**

The height and breadth shall be measured correct to a cm. The height of the gate shall be measured as the length of the double channels and breadth from outside to outside of the end fixed double channels in open position, of the gate. The area shall be calculated in square metres, correct to two places of decimal.

#### **10.5.5 Rate**

The rate shall include the cost of materials and labour involved in all the operations described above.

#### **10.6 M.S. SHEET SLIDING SHUTTER**

**10.6.0** These shall be manufactured as per drawings and specification. These shall be fabricated from mild steel sheets.

**10.6.1** The shutters shall be double or single leaf shutter as specified. The shutters shall be fabricated of specified size of M.S. angle iron frame diagonally braced with the same size of M.S. angle riveted / welded together with 3mm gusset plate at junction to form a rigid frame. M.S. sheet of 1 mm thickness or as specified shall be fixed to the frame with rivets/welds as approved by the Engineer-in-charge. These shall also be provided with top and bottom guide rails of specified size angles or T- irons and 25 mm diameter pulley or with 25 mm diameter ball bearing at the bottom and guide block with steel pulleys at the top. The shutters shall also be provided with locking arrangement, handles, stoppers, and holdfasts, other fittings as specified in the description of the item. The guide rails shall be sufficiently long and continued along the wall on both ends so that the sliding shutters can rest against the walls, giving full opening when so required.

### **10.6.2 Fixing**

The guide rails shall be fixed to the floor by means of anchor bolts embedded in the cement concrete floor. The steel section at the top shall be suitably supported from the walls. Two channel sections shall be suitably fixed vertically below the extreme clamps in the wall and floor to avoid the shutter from going out of the supports at top and bottom. A suitable clamping arrangement will be provided at either end of the opening to avoid the shutters from rolling back into the opening. All the adjoining work damaged in fixing shall be made good to match the existing work.

### **10.6.3 Painting**

All members of the sliding shutters including fittings shall be thoroughly cleaned of rust, scales, dust etc. and given a priming coat of approved steel primer i.e. Red oxide zinc chrome primer conforming to IS 2074 before fixing them in position.

### **10.6.4 Measurements**

The height and width shall be measured correct to a cm and its area for payment shall be calculated in square metres correct to two places of decimal. The height of the shutter shall be measured from outside to outside of the guide rail and width out side to out side of the shutter including the vertical position channels in sides, when shutter closed.

### **10.6.5 Rate**

The rate shall include the cost of materials and labour involved in all the operation described above. It also includes the cost of the full length of guide rails.

## **10.7 M.S. SHEET SHUTTERS**

**10.7.0** These shall be manufactured as per drawing and specification. These shall be fabricated from mild steel sheets and angle iron.

**10.7.1** The doors shall be provided as double leaf shutters unless otherwise specified. The shutters shall be fabricated with frame of M.S. angle 40 x 40 x 6 mm @ 3.5 kg/ metre and two diagonal braces of the same section as shown in Fig. 3 unless otherwise specified. The frame shall be riveted and/ or welded at the junctions. Wherever riveting shall be done 3.15 mm (10 G) thick gusset plate shall be provided at the junction. M.S. sheet of 1 mm thickness or as specified, shall be fixed to the frame with rivets or welds as approved by the Engineer-in-charge. Alternatively the diagonal bracing may be replaced by one horizontal and two cross flats 30 x 6 mm

as shown in Fig. 10.3 unless otherwise specified. The outer frame shall be provided with cleats made of section 40 x 10 mm and bent in the shape of angle cleats with one arm 150 mm long and the other arm 50 mm long and fixed to the angle iron frame of the door with two 12 mm dia bolts and nuts. For doors upto 2.40 m height, two angles cleats per door shall be provided. The cleat shall have a vertical leg of 150 mm which shall be fixed with frame and horizontal leg of about 50 mm which shall be provided with a hole of 24 mm dia and fixed in the projected pin of the pin clamp.

### **10.7.2 Fittings and Fixtures**

The shutters shall be fixed to the wall masonry with four pin clamps (pintles) where the height of the shutter is upto 2.4 m. Each pin clamp shall consist of 50 x 6 mm flat iron 45 cm long bent and forked at one end and provided with 20 mm diameter M.S. pin on the other. The pin shall be firmly riveted or welded to the pin clamp, the other end of which shall be embedded in masonry by means of cement concrete block 40 x 23 x 20 cm of 1:3:6 mix (1 cement :3 coarse sand:6 graded stone aggregate 20 mm nominal size). It shall be so placed that bottom pin shall face upwards and "top pin downward" in order that the gate may not be removed by lifting over pins. One hook with eye 45 cm long of 10 mm diameter shall be provided for each shutter to keep it fixed in open position. The hook shall be fixed in wall masonry with wooden block and the eye shall be fixed on 6 mm thick M.S. plate as staple and fixed in the shutter frame with rivet or weld. A cement concrete block 15 x 10 x 20 cm in 1:2:4 (1 cement:2 coarse sand:4 grades stone aggregate of 20 mm nominal size) mix shall be embedded in the floor or at junction of two shutters so that door shutter open only on the outside and not on the inside. The shutters shall also be provided with locking



arrangement and two handles of the shape and pattern as approved by the Engineer-in-charge.

### **10.7.3 Painting**

All the members of the door including angle iron shall be thoroughly cleaned off rust, scales, dust etc. and given a priming coat of approved steel primer i.e. Red Oxide/ Zinc chrome primer conforming to IS 2074 before fixing them in position.

### **10.7.4 Measurements**

The width and height of shutters shall be measured to the nearest cm. The area shall be calculated in square metre correct to two places of decimal.

### **10.7.5 Rate**

The rate shall include the cost of materials and labour involved in all the operation described above. Nothing extra shall be paid for cement concrete block or wooden blocks nor anything deducted for these from the measurement of the masonry wall.

## **10.8 ROLLING SHUTTERS**

**10.8.1** Rolling shutters shall conform to IS 6248. These shall include necessary locking arrangement and handles etc. These shall be suitable for fixing in the position as specified i.e. outside or inside on or below lintel or between jambs of the opening. The door shall be either push and pull type or operated with mechanical device supplied by the firm. Shutters upto 10 sq. metre shall be of push and pull type and shutters with an area of over 10 sq. metre shall generally be provided with reduction gear operated by mechanical device with chain or handle, if bearings are specified for each of operation, these shall be paid for separately.

**10.8.1.1 Shutter** : The shutter be built up of inter locking lath section formed from cold rolled steel strips. The thickness of the sheets from which the lath sections have been rolled shall be not less than 0.90 mm for the shutters upto 3.5 m width. Shutters above 9 metres width should be divided in 2 parts with provision of one middle fixed or movable guide channel or supported from the back side to resist wind pressure. The lath section shall be rolled so as to have interlocking curls at both edges and a deep corrugation at the centre with a bridge depth of not less than 12 mm to provide sufficient curtain of stiffness for resisting manual pressures and normal wind pressure. Each lath section shall be continuous single piece without any welded joint. When interlocked, the lath sections shall have a distance of 75 mm rolling centers. Each alternate lath section shall be fitted with malleable cast iron or mild steel clips securely riveted at either ends, thus locking in the lath section at both ends preventing lateral movement of the individual lath sections. The clips shall be so designed as to fit the contour of the lath sections.

**10.8.1.2 Spring** : The spring shall be of coiled type. The spring shall be manufactured from high tensile spring steel wire or strips of adequate strength conforming to IS 4454- Part I.

**10.8.1.3 Roller and Brackets** : The suspension shaft of the roller shall be made of steel pipe conforming to heavy duty as per IS 1161. For shutter upto 6 metre width and height not exceeding 5metre, steel pipes of 50 mm nominal bore shall be used. The shaft shall be supported on mild steel brackets of size 375 x 375 x 3.15 mm for shutters upto a clear height of 3.5 metre. The size of mild steel brackets shall be 500 x 500 x 10 mm for shutters of clear height above 3.5 m and upto 6.5 m. The suspension shaft clamped to the brackets shall be fitted with rotatable cast iron pulleys to which the shutter is attached. The pulleys and pipe shaft shall connected by means of pretensioned helical springs to counter balance the weight of the shutter and to keep the shutter in equilibrium in any partly open position.

**10.8.1.4** When the width of the opening is greater than 3.5 mtr. The cast iron pulleys shall be interconnected with a cage formed out of mild steel flats of at least 32 x 6 mm and mild steel dummy rings made of similar flats to distribute the torque uniformly. Self aligning two row ball bearing with special cast iron casings shall be provided at the extreme pulley and caging rings shall have a minimum spacing of 15mm and at least 4 number flats running throughout length of roller shall be provided.

**10.8.1.5** In case of shutters of large opening with mechanical device for opening the shutter the roller shall be fitted with a purion wheel at one end which in contact with a worm fitted to the bracket plate, caging and pulley with two ball bearing shall be provided.

**10.8.1.6 Guide Channel :** The width of guide channel shall be 25 mm the minimum depth of guide channels shall be as follows:

<i>Clear width of shutters</i>	<i>Depth of guide channel</i>
Upto 3.5 m	65 mm
3.5 m upto 8 m	75 mm
8 m and above	100 mm

**10.8.1.7** The gap between the two legs of the guide channels shall be sufficient to allow the free movement of the shutter and at the same time close enough to prevent rattling of the shutter due to wind.

**10.8.1.8** Each guide channel shall be provided with a minimum of three fixing cleats or supports for attachment to the wall or column by means of bolts or screws. The spacing of cleats shall not exceed 0.75 m. Alternatively, the guide channels may also be provided with suitable dowels, hooks or pins for embedding in the walls.

**10.8.1.9** The guide channels shall be attached to the jambs, plumb and true either in the overlapping fashion or embedded in grooves, depending on the method of fixing.

**10.8.1.10 Cover :** Top cover shall be of mild steel sheets not less than 0.90 mm thick and stiffened with angle or flat stiffeners at top and bottom edges to retain shape.

**10.8.1.11** Lock plates with sliding bolts, handles and anchoring rods shall be as per IS 6248.

### **10.8.2 Fixing**

The arrangement for fixing in different situations in the opening shall be as per IS 6248.

**10.8.2.1** Brackets shall be fixed on the lintel or under the lintel as specified with rawl. Plugs and screws bolts etc. The shaft along with the spring shall then be fixed on the brackets.

**10.8.2.2** The lath portion (shutter) shall be laid on ground and the side guide channels shall be bound with ropes etc. The shutter shall then be placed in position and top fixed with pipe shaft with bolts and nuts. The side guide channels and cover frames shall then be fixed to the walls through the plate welded to the guides. These plates and bracket shall be fixed by means of steel screws bolts, and rawl plugs concealed in plaster to make their location invisible. Fixing shall be done accurately in a workmen like manner that the operation of the shutter is easy and smooth.

### **10.8.3 Measurements**

Clear width and clear height of the opening for rolling shutter shall be measured correct to a mm. The clear distance between the two jambs of the opening shall be clear width and the clear distance between the sill and the soffit (bottom of lintel) of the opening shall be the clear height. The area shall be calculated in square metres correct to two places of decimal.

### **10.8.4 Rate**

The rate shall include the cost of materials and labour involved in all the operations described above including cost of top cover and spring except ball bearing and mechanical device of chain and crank operation, which shall be paid for separately.

## **10.9 ROLLING GRILLS – SHUTTERS**

**10.9.0** Rolling grill shutter is meant to provide visibility or ventilation or both, the degree of protection and safety is less as compared to a rolling shutter. The situations where a certain amount of ventilation combined with safety is required rolling shutter-cum-grill may be provided in which the rolling shutter may have a rolling grill portion either at the top or at the bottom or at both places. In addition, the rolling grill portion may also be provided in the middle of the shutter. The total height of the grill portion in all the segments of rolling shutter-cum-grill shall not exceed 1.0 m and the height of the grill portion in any individual segment shall not be more than 0.5 m.

**10.9.1** Rolling grills shutters are similar in design, construction and operation to rolling shutters and all the provisions of Para 10.8 shall be applicable to rolling grills shutters except in respect of the shutterportion, and shall conform to IS 6248.

### **10.9.2 Shutters**

Rolling grill shutter and the rolling grill portion of the rolling shutter-cum-grill shall be fabricated with 8 mm diameter mild steel round bars. Straight bars and bars bent to the required profile are placed alternatively and held in position with 20 mm wide and 5 mm thick mild steel flat links. Straight bars shall be spaced not exceeding 150 mm centre to centre and the bars bent to required profile shall be placed symmetrically between two consecutive straight bars. Unless otherwise specified or directed by the Engineer-in-charge, bars placed alternatively with straight bars shall be bent to form a corrugated profile such that the pitch of the corrugation is 100 to 120 mm and the depth of corrugation is 80 to 100 mm. All the bent bars shall have uniform profile. Straight bar along with the adjoining bent bars on it both sides shall be held in position by passing the bars through holes in the links. Each link shall have three holes and the length of the links shall be such that the distance from the centre of the hole to the nearest edge of the flat is not less than the diameter of the hole. The corner of the links shall be rounded. All links shall be of uniform size and shape. The spacing of the links measured along the straight bar shall be the same as centre to centre distance between two consecutive crests/ troughs of the bars bent to the required profile. Each bar and link shall be continuous single piece without any joint.

### **10.9.3 Measurement & Rate**

The measurement and rate shall be as specified in 10.8.3 and 10.8.4 respectively. In case of Rolling Shutter-cum-Grill, where the area of the grill portion is half or less than half the area of opening, it shall be measured and paid as rolling shutter and where the area of grill portion is more than half the area of opening, it shall be measured and paid as rolling grill.

### **10.10 STEEL DOORS, WINDOWS, VENTILATORS AND COMPOSITE UNITS (Fig. 10.4)**

Hot rolled steel sections for fabrication of steel doors, windows, ventilators and fixed lights shall conform to IS 7452. Shapes weights and designations of hot rolled sections shall be as per IS 7452. Appendix 'D' indicates the purpose or the situation where the sections are normally used. Tolerance in thickness of the sections shall be + 0.2 mm. The fabricated steel doors, windows, ventilators and composite units shall conform to IS 1038 with up-to-date amendments and shall be IS marked (IS 1038).

**10.10.1** The steel doors and windows shall be according to the specified sizes and design. The size of doors and windows shall be calculated, so as to allow 1.25 cm clearance on all the four sides of opening to allow for easy fitting of doors windows and ventilators into opening. The actual sizes of doors, windows and ventilators shall not vary by more than + 1.5 mm from those given in the drawing.

#### **10.10.2 Fabrication**

**10.10.2.1.1 Frames :** Both the fixed and openable frames shall be made of sections which have been cut to length and mitred. The corner of fixed and openable frames shall be welded to form a solid fused welded joint conforming the requirements given below. All frames shall be square and flat. The process of welding adopted shall be flush but welding or can be any other process as agreed to between the supplier and the purchaser which shall fulfil the requirements given in clause 6.1.1 of IS 1038, metal arc welding or any other suitable method. The section for glazing shall be tenoned and riveted into the frames and where they intersect the vertical tie shall be broached and horizontal tee threads through it, and the intersection closed by hydraulic pressure.

#### **10.10.2.1.2 Requirements of Welded Joints**

(i) **Visual Inspection Test:** When two opposite corners of the frame are cut, paint removed and inspected, the joint shall conform to the following:-

(a) Welds should have been made all along the place of meeting the members and tack welding shall not be permitted.

(b) Welds should have been properly grounded and

(c) Complete cross section of the corner shall be checked up to see that the joint is completely solid and there are no cavities visible.

(ii) **Micro and Macro Examinations:** From the two opposite corners obtained for visual test, the flanges of the sections shall be cut with the help of a saw. The cut surface of the remaining portions shall be polished, etched and examined. The polished and etched faces of the weld and the base metal shall be free from cracks and cavity and reasonably free from under cutting overlaps, gross porosity and entrapped slag.

(iii) **Fillet Weld Test:** The fillet weld in the remaining portion of the joint shall be fractured by hammering. The fractured surfaces shall be free from slag inclusion porosity, crack penetration defects and fusion defects.

**10.10.2.2 Doors :** The hinges shall be of 50 mm projecting type, Non projecting type hinges may also be used, if approved by Engineer-in-Charge. The hinge pin shall be of electro-galvanized steel or aluminum alloy of suitable thickness and size. Door handles shall be approved by the Engineer-in- Charge. A suitable latch lock for door openable both from inside and outside shall be provided. In the case of double doors, the first closing leaf shall be the left hand leaf locking at the door from the push side. The first closing shutter shall have a concealed steel bolt at top and bottom. The bolts shall be so constructed as not to work loose or drop by its own weight. Single and double leaf shutter door may be provided with a three way bolting device. Where the device is provided in the case of double leaf shutters, concealed brass or steel bolts shall not be provided.

#### **10.10.2.3 Windows**

(a) For fixed windows, the frames shall be fabricated as per 10.10.2.1.1.

(b) Side hung windows.

For fixing steel hinges, slots shall be cut in the fixed frame and hinges inserted inside and welded to the frame at the back. The hinges shall be of projecting type with thickness not less than 3.15 mm and length not less than 65 mm and width not more than 25 mm. Non projecting type hinges may also be allowed if approved by the Engineer-in-Charge. The diameter of hinge pins shall not be less than 6 mm. The hinge pin and washer shall be of galvanized steel or aluminum alloy of suitable thickness. For fixing hinges to inside frame, the method described above may be adopted but the weld shall be cleaned, or the holes made in the inside frame and hinge riveted. The handle of side hung shutters shall be pressed brass, cast brass, aluminium or steel protected against rusting and shall be mounted on a steel plate. Thickness of handle shall not be less than 3 mm in case of steel or brass and 3.5 mm in case of aluminium. The handle plate shall be welded, screwed and/ or riveted to the opening frame in such a manner that it should be fixed before the shutter is glazed and should not be easily removable after glazing. The handle shall have a two point nose which shall engage with a brass or aluminium alloy striking plate on the fixed frame in a slightly opened position as well as closed position. The boss of handle shall incorporate a friction device to prevent the handle from dropping under its own weight and the assembly shall be so designed that the rotation of the handle may not cause it to unscrew from the pin. The height of the handle plate in each type of standards windows will be as specified, otherwise it shall be at a height of 3/8 of the height of shutter, from its bottom. The strike plate shall be so designed and fixed in such a position in relation to the handle that with the later bearing against its stop, there shall be adequately tight fit between the casement and outer frames. In case where no friction type hinges are provided, the windows shall be fitted with peg stays which shall be either of black oxidised steel, pressed or cast brass or as specified, 300 mm long or as specified with steel peg and locking brackets. The pegs stay shall have three holes to open the side hung casement in three different angles. The peg stay shall be of minimum thickness 2 mm in case of brass or aluminium and 1.25 mm in case of steel. Where specified friction hinges shall be provided. Side hung shutters fitted with friction hinges shall not be provided with a peg stay. If specified, side hung shutters may be fitted with an internal removable fly proof screen in a 1.25 mm thick sheet steel frame to the outer frame of the shutter by brass turn buckles at the jambs, and brass studs at the sill to allow the screen being readily removed. The windows with removable fly proof screen shall be fitted with a through – the screen level operator at the sill level to permit the operation of the shutter

through an angle of 90° without having to remove the fly proof screen. The lever shall permit keeping the shutter open in minimum three different positions.

#### **10.10.2.4 Ventilators**

##### *(a) Top Hung Ventilators*

The steel butt hinges for top hung ventilators shall be riveted to the fixed frame or welded to it at the back after cutting a slot in it. Hinges to the opening frame shall be riveted or welded. Top hung ventilators shall be provided with a peg stay with three holes which when closed shall be held tightly by the locking bracket. The locking bracket shall either be fitted to the fixed frames or to the window.

##### *(b) Centre Hung Ventilators*

Central hung ventilators shall be hung on two pairs of brass or aluminium cup pivots as specified, riveted to the inner and outer frames of ventilators to permit the ventilator shutter to swing to angle of approx 85°. The opening portion of the ventilators shall be so balanced that it remains open at any desired angle under normal weather conditions.

**10.10.2.4.1** A black oxidised steel spring catch approved by the Engineer-in-Charge shall be fitted in the centre of the top of the centre hung ventilator, for the operation of ventilators. The spring catch shall be secured to the frame with M.S. screws and shall close into a mild steel or malleable iron catch plate riveted, screwed or welded to the outside of the outer window frame bar.

**10.10.2.4.2** A black oxidised cord pulley wheel in galvanized mild steel brackets shall be fitted at sill of the centre hung window with mild steel screws or alternatively welded together with mild steel or malleable iron cord-eye riveted or welded to the bottom inner frame bar of the window in a position corresponding to that of pulley. Removable fly-proof screen may be provided as specified in 10.10.2.3 (b). This shall be fitted with a through – the screen operator to enable operating and keeping the shutter open in minimum three different positions.

**10.10.2.5 Composite Units :** Composite Units consist of a combination of two or more units of doors, windows and ventilators etc. as the case may be. The different units shall be coupled by using coupling sections K-11B or K-12B (Ref. Appendix D) as the case may be. Wherever the ventilators, windows and doors shall be coupled with a coupling sections, mastic cement shall be applied between the junction to make the joint water tight.

#### **10.10.3 Glazing**

**10.10.3.1** Specifications described in para 9.6.4.6 shall apply. The glass panes shall have square corners and straight edges. The glass panes shall be so cut that it fits slightly loose in the frames. In doors, windows and clerestory windows of bath, WC and lavatories frosted glass panes shall be used which shall weight not less than 10.00 kg/m<sup>2</sup>.

**10.10.3.2** Glazing shall be provided on the outside of the frame unless otherwise specified. Putty of approved make conforming to IS 419 shall be used for fixing glass panes. Putty shall be applied between glass panes and glazing bars. Putty shall then be applied over the glass pane, which shall stop 2 to 3 mm from the sight line of the back rebate to enable the painting to be done upto the sight line to seal the edge of the putty to the glass. The oozed out putty shall be cleaned and from putty cut to straight line. Quantity of putty shall not be less than 185 gm/ metre of glass perimetre. Putty shall be painted within 2 to 3 weeks, after glazing is fixed to avoid its cracking.

**Note:** Putty may be prepared by mixing one part of white lead with three parts of finely powdered chalk and then adding boiled linseed oil to the mixture to form a stiff paste and adding varnish to the paste at the rate of 1 litre of varnish to the 18 kg paste.

**10.10.3.3** Four glazing clips may be provided per glass pane for a size larger than 30 cm x 60 cm for all types, where the glass panes size exceed 80 cm x 200 cm, 6 glazing clips shall be used. In case of doors, windows and ventilators without horizontal glazing bars, the glazing clips may be spaced according to the slots, in the vertical members provided the spacing does not exceed 30 cm otherwise the spacing shall be 30 cm.

**Note:** Where large size glass panes are required to be used or where the door or window is located in heavily exposed situation, holes for glazing clips have to be drilled prior to

fabrication and cannot be done at any later stages. Use of glazing clips shall be specified while placing the order.

**10.10.3.4** Where specially stipulated, fixing of glass panes may be done with metal or wooden beading instead of mere putty. Where beading are proposed to be used, the manufacturers shall be intimated in advance to drill holes for hard screws. Usually beads shall be fixed with screws spaced not more than 10 cm from each corner and the intermediate not more than 20 cm apart. When glass panes are fixed with wooden or metal beading having mitred joints, a thin layer of putty shall be applied between glass panes and sash bars and also between glass panes and the beading. Size of M.S. beading shall be 10 x 10 mm box section manufactured from 1.6 mm thick sheet unless otherwise specified in the item. Where metal beading is specified, extra payment shall be made on this account.

#### **10.10.4 Finishing**

All steel surfaces shall be thoroughly cleaned of rust, scale and dirt. Where so specified. The steel surface shall be treated for rust proofing by the hot dip, zinc spray or electro galvanizing process. A priming coat of approved steel primer i.e. red oxide/ zinc chromate perimer conforming to IS 2074 shall be given. The fabricated steel door, windows, ventilators and composite units shall be inspected in the factory and approved by the Engineer-in-charge before priming coat is applied. Final finishing coat shall be given to the doors, windows and ventilators after they are erected and fixed in final position. The rate shall be exclusive of final finishing coats but shall include the priming coat.

#### **10.10.5 Fixing**

**10.10.5.1** Steel, doors and windows shall be so stacked as to keep them in true shape without damage. Doors, windows and ventilators shall be fixed as described below.

**10.10.5.2** Opening may be flush or rebated as shown in the drawing. The opening may have rendered finish or a "fair faced" finish (i.e. without rendering as in case of marble or stone facing). Where openings are flush and with a rendered finish a clearance of 1.25 cm shall be provided between the steel frame and opening (See Fig. 10.6). In case of external masonry finish "fair faced" and with rebated jambs, a minimum 1.25 cm clearance between frame and opening shall provided (See Fig. 10.6) opening in steel work shall be so designed that the outer flange of the door, windows, or ventilator frame section overlaps the steel surface by 10 mm (see Fig. 10.6)

**Note :** The sizes of Indian Standard doors, windows and ventilators, are designed for modular opening 1.25 cm larger all round than the doors, windows etc. This gap of 1.25 cm is for the purpose of fixing of doors, windows etc. In masonry opening, the gap is filled up with mastic cement and plaster after the door or windows is fixed in position. In the case of steel or timber modular opening, extra steel or timber fillets will be necessary to cover this gap of 1.25 cm.

#### **10.10.5.3 Fixing in Masonry Openings**

##### *(a) Fixing with Lugs*

(i) Doors, windows and ventilators unit, shall not be "built in" as the work proceeds but opening shall be left out and frames fitted afterwards so that the minimum specified clearance between opening and unit frame is left around. The size of the opening shall first be checked and cleared of obstruction, if any. The position of the unit and fixing holes shall be marked on the jamb. Necessary holes shall be made in the masonry and lugs not less than 10 cm long 15 x 3 mm size M.S flat fixed in cement concrete blocks 15 x 10 x 10 cm size of 1:3:6 mix (1 cement : 3 coarse sand:6 graded stone aggregate 20mm nominal size). The frames of units shall be set in the opening by using wooden wedges at the jamb, head and sill, (wedges shall preferably be placed near the points where a glazing bar meets the frames and be plumbed in position).

(ii) After, the frame shall be fixed with the lugs with 20 mm long and 6.3 mm dia. G.I. counter sunk machine screws and nuts. In case of flush opening which are rendered smooth, wedges shall be removed and gap between unit and the jambs shall be filled with cement mortar (Fig. 10.6)

(iii) In case of flush jamb with external “fair faced” finish the gap between the opening and frame shall be filled with mastic from inside till it oozed out on external face. The oozing mastic shall be cleaned and flush pointed. The internal gap shall be filled with mastic to about 1/3rd depth the rest with cement mortar (Fig. 10.6).

(iv) In case of rebated jambs and jambs finished “fair faced” externally, the mastic shall be freely applied to the inside channel of frame, jamb and sill, so as to ensure a watertight joint. After the units is firmly fixed in position surplus mastic shall be cleaned and flush pointed, as shown in Fig. 10.6.

(b) *Fixing with Screws and Plugs:* In R. C. C. work where lugs cannot be embedded due to reinforcement bars etc. rawl plugs or other approved metallic fasteners may be fixed in proper position and frame fixed to them with 60 mm galvanized cross recessed head wood screws of designation 10.

**10.10.5.4 Fixing in Wood Work Opening :** Opening in wood work are normally rebated and approved mastic or rubber linings shall be applied to jambs, sill and channel before fixing in position, the frame shall be set in opening using wooden wedges as specified in 10.10.5.3 and fixed to the opening with 60 mm galvanized wood screws of designation 10. Extra timber fillets of hard wood to match the adjoining work shall also be provided around the frame to close the extra gap between opening and frame (Fig. 10.6).

**10.10.5.5 Fixing in Steel Work Opening :** Before placing the unit frame in position approved mastic shall be applied as specified in 10.10.5.3 (a) (iv) and a mild steel or hard wood fillet shall be provided around the frame to close the extra gap between opening and frame. The unit shall then be fixed to the opening with fixing clips or with nuts and bolts as shown in the drawings or as directed by the Engineer-in-Charge (Fig. 10.6)

**10.10.5.6 Fixing of Composite Units :** The fixing procedure for composite units shall generally be as described under 10.10.5.1 to 10.10.5.5 except that:

Where large units shall be formed by coupling individual units together (with coupling sections), the mullions and transom shall be bedded in mastic to ensure water tightness. Mastic shall be applied liberally to the channels of the outside frame section before assembly and after coupling. All oozing out mastic shall be cut out neatly.

#### **10.10.6 Precautions**

Care shall be taken that steel doors and windows etc. are not deformed/ damaged during subsequent constructions. Particular care shall be taken that scaffolding do not rest on the steel door window frames or glazing bars. All fittings and hinges (projecting hinges) shall be protected, preferably with alkathene sheets so that these may not be damaged during execution of work.

#### **10.10.7 Measurement**

The weight of finished section door/windows of different sizes, inclusive of all fixed /welded fittings i.e. hinges pivots, lugs, brackets striking plates etc., shall be worked out before fixing of windows (exclusive of weight of glass panes, glazing clips, putty etc.). Sectional weight of steel members only shall be measured without weight of glass panes etc. Any loose fittings such as casement stays/fastners etc. shall be enumerated and paid for separately.

#### **10.10.8 Rate**

Rate shall include the cost of materials and labour involved in all the operations described above excluding two coats of painting but including cost of glazing and priming including the cost of projecting hinges in case of side hung doors/windows, plain hinges in case of top/ bottom hung windows /ventilators and pivots for centre hung windows/ ventilators. Metal beading and other fittings such as peg stay and casement window fasteners etc. shall be enumerated and paid for separately.

### **10.11 T-IRON DOORS, WINDOWS AND VENTILATORS FRAMES.**

**10.11.0** T-iron doors, windows and ventilators frames shall be manufactured from uniform mild steel Tee section. The steel shall be of the grade as provided in 10.1.1 The frames shall be got fabricated in approved workshop as approved by the Chief Engineer.

**10.11.1** The sizes of doors, windows and ventilator frames shall be as per drawing or as decided by the Engineer-in-Charge. MS tie bar of 10 mm dia shall be welded at bottom of the frame. The size of doors, window and ventilators shall be calculated so as to allow 12.5 mm clearance on all sides to allow an easy fittings in opening. The actual size of doors, windows and ventilator shall not vary by more than + 2 mm than those shown in the drawings. The size of T section used for manufacture of doors, windows and ventilators shall not be less than those specified in IS 1038 (see Fig. 10.5) unless otherwise directed by the Engineer-in-charge.

#### **10.11.2 Fabrications**

The frame shall be constructed in section which has been cut to length and mitred. The corners of the frames shall be butt welded to form a true and right angle. All frames shall be square and flat meeting the requirements stated under para 10.10.2.1.1.

The T Sections shall be mitre joined and continuously butt welded all along. The requirement of welded joints shall be as specified under para 10.10.2.1.2.

#### **10.11.3 Fittings**

Requisite number of holes shall be made in the frame for fixing of fitting. Detailed arrangement of fixing fittings shall be as shown in Fig. 10.7. All fitting shall be fillet welded to T iron frame all along the periphery of contact.

Butt hinges shall be fixed to the frame as below:

(i) MS flat of size 100 mm x 25 mm x 6 mm will be welded with fillet weld all along the periphery of contact on the rear side of the web of T iron to receive the hinges. Requisite number of holes shall be made in T iron frame and MS flat for fixing of hinges with counter sunk steel screws as shown in Fig. 10.7.

(ii) An alternate method of fixing butt hinges can be adopted by fillet welding the hinge to the T iron frame on three sided. No welding shall be done along the hinge pin to allow free movement of butt hinges as shown in Fig. 10.7.

#### **10.11.4 Fixing Procedure**

Fixing procedure for T iron doors, windows and ventilator frames in masonry opening shall be as described in 10.10.5. Fixing arrangements of shutters to such frames is shown in Fig. 10.5.

#### **10.11.5 Measurements**

T- iron door windows and ventilator frames shall be measured in running metre, along the centre line of the frame correct to a 1mm and weight calculated on the basis of standard tables. No deduction or extra payment shall be made for making holes and making arrangement for fixing fittings including packing wherever necessary. No deduction will be made for not providing tie bars in case of windows and ventilators.

#### **10.11.6 Rate**

The rate includes cost of materials and labour involved in all the operation described above. It shall include the necessary butt hinges and screws for fixing the same with frame or as specified. But it does not include the cost of other door, window and ventilator fittings.

### **10.12 PRESSED STEEL DOOR FRAMES (Fig. 10.8)**

#### **10.12.1 Materials**

Steel door frames shall be manufactured from commercial mild steel sheet of specified thickness, conforming to IS 2062 and 4351. Steel door frames with or without fan light shall be made in the profiles indicated in Fig. 10.8 which may be manufactured to suit doors of either type opening inwards or outwards as directed by the Engineer-in-Charge.

#### **10.12.2 Construction**

Each door frame shall consist of hinge jamb, lock jamb, head and if required angle threshold (see Fig. 10.8.) These shall be welded or rigidly fixed together by mechanical means. Where no angle threshold is required, temporary base tie shall be screwed to the feet of frames in order to form a rigid unit. Where so specified base ties shall be of pressed mild steel 1.25 mm thick adjustable to suit floor thickness of 35 or 40 mm and removable, or alternatively, threshold of mild steel angle of section 50 x 25 mm, minimum shall be provided for external doors frames.



### **10.12.3 Fabrication**

The pressed steel door frames shall be got fabricated in an approved workshop as approved by the Chief Engineer.

**10.12.3.1 Fixing Lugs (Fig. 10.8) :** There shall be three adjustable lugs with split end tail to each jamb without fan light, and four for jamb with fan light.

The head of the fixing lug shall be of one of the following lengths:

- (a) 98 mm long for use with profile A
- (b) 120 mm long for use with profile B
- (c) 160 mm long for use with profile C

The head shall be made from flat steel strip 25 mm wide and not less than 1.60 mm thick. The tail of the lugs shall be 200mm long and shall be made of steel strip not less than 40 mm wide and not less than 1 mm thick.

**10.12.3.2 Hinges (Fig. 10.8) :** 100 mm mild steel butt hinges shall be used. For door frames 80 cm wide and under, three hinges shall be rigidly fixed to one jamb and for door frames above 80 cm wide, four hinges shall rigidly fixed to one jamb, if it is single shutter, where the height of door shutter exceeds 2.15 metres, one additional hinge shall be provided for every 0.5 m or part thereof the additional height. In all cases the hinges shall be so fixed that the distance from the inside of the head rebate to the top of the upper hinge is 20 cm and the distance from the bottom of the door frame to the bottom of the bottom hinge is also kept about 200 mm. The middle hinges shall be at equal distances from lower and upper hinges or as agreed to between the purchaser and the supplier. Hinges shall be made of steel 2.5 mm thick with zinc coated removable pin of 6 mm diameter. The space between the two leaves of the hinge when closed shall be 3 mm and the leaf that is not welded to the frame shall have four counter sunk holes to take No. 10 cross recessed head wood screws.

**10.12.3.3 Mortar Guards :** Mortar guards of thickness of main frame sheet shall be provided in accordance to provisions of IS 4351 and as instructed by Engineer-in-charge shall be provided. These shall be welded to the frame at the head of the frame for double shutter doors to make provision for bolts. These shall also be provided to the frame behind the hinges, mortice locks and latches, slots, aldrop and sliding /tower bolts.

**10.12.3.4 Lock – Strike Plate :** There shall be an adjustable lock- strike plate of steel complete with mortar guard to make provision for locks or latches complying with the relevant Indian Standards.(IS 4351) Lock-strike plates shall be of galvanized mild steel and fixed at 95 cm from the head of the frame.

**10.12.3.5 Shock Absorbers :** For side hung door there shall not be less than three buffers or rubber or other suitable material inserted in holes in the rebate. one shall be located at the centre of the lock jamb and the other two shall be at 30 cm. from top and bottom of the frame. For double leaf shutter door, two buffers shall be provided.

### **10.12.4 Finishing**

The surface of door frame shall be thoroughly cleaned, free of rust, mill-scale dirt oil etc. either by mechanical means, for example sand or shot blasting or by chemical means such as picking. After pretreatment of the surface one coat of approved primer i.e. red oxide zinc chrome primer conforming to IS 2074. Two coats of paints as directed by the Engineer-in-charge shall be applied to the exposed surface.

### **10.12.5 Fixing**

Frames shall be fixed up right in plumb and plane. To avoid sag or bow in width during fixing or during construction phase, temporary struts across the width preventing sides bulging inwards may be provided. Wall shall be built solid on each side and grouted at each course to ensure solid contact with frame leaving no voids behind the frame. Three lugs shall be provided on each jamb with spacing not more than 75 cm. The temporary struts should not be removed till the masonry behind the frame is set. In case screwed base tie is provided, this should be left in position till the flooring is laid when it can be removed. After pretreatment of the surface, one coat of steel primer and two coats, of paint, as directed by Engineer-in-charge shall be applied to the exposed surface.

### **10.12.6 Measurements**

The length shall be measured in running metre correct to a cm along the centre line of the frames.

#### **10.12.7 Rate**

The rate shall include the cost of labour and material involved in all the operation described above including one coat of approved steel primer but excluding two coats of paint.

### **10.13 TUBULAR / HOLLOW SECTION TRUSSES**

#### **10.13.1 Structural Steel Tube**

These shall be of:

1. Hot finished welded (HFW) type, or
2. Hot finished seamless (HFS) type, or
3. Electric resistance or induction butt welded (ERW), having carbon content less than 0.03 percent, yield stress of 21.5 kg/mm<sup>2</sup> (YST 210) type. Conforming to the requirement of IS 1161. The steel tubes when analysed in accordance with the method specified in IS 228 shall show not more than 0.06 percent sulphur, and not more than 0.06 per cent phosphorous. Tubes shall be designated by their nominal bore. These shall be light, medium or heavy as specified depending upon the wall thickness. The standard size and weights of tubes are listed in Appendix C. Hollow sections shall be as per IS 4923. Tubes shall be clean finished and reasonably free from scale. They shall be free from cracks, surface flaws, laminations and other defects. The ends shall be cut clean and square with axis of tube, unless otherwise specified.

#### **10.13.2 Minimum Thickness of Metals**

Wall thickness of tubes used for construction exposed to weather shall be not less than 4 mm and for construction not exposed to weather it shall be not less than 3.2 mm where structures are not readily accessible for maintenance, the minimum thickness shall be 5 mm.

#### **10.13.3 Fabrication**

**10.13.3.1** The component parts of the structure shall be assembled in such a manner that they are neither twisted nor otherwise damaged and be so prepared that the specified cambers, if any, are, maintained. The tubular steel work shall be painted with one coat of approved steel primer after fabrication. All fabrication and welding is to be done in an approved workshop. The joint details shall be generally as per S.P-38 of B.I.S publication.

**10.13.3.2 *Straightening*** : All material before being assembled shall be straightened, if necessary, unless required to be of curvilinear form and shall be free from twist.

**10.13.3.3 *Bolting*** : Washers shall be specially shaped where necessary, or other means, used to give the nuts and the heads of bolts a satisfactory bearing. In all cases, where the full area of the bolts is to be developed, the threaded portion of the bolt shall not be within the thickness of the parts bolted together and washers of appropriate thickness shall be provided to allow the nuts to be completely tightened.

**10.13.3.4 *Welding*** : Where welding is adopted, it shall be as per IS 816.

**10.13.3.5 *Caps and Bases for Columns*** : The ends of all the tubes, for columns transmitting loads through the ends, should be true and square to the axis of the tubes and should be provided with a cap or base accurately fitted to the end of the tube and screwed, welded or shrunk on. The cap or base plate should be true and square to the axis of the column.

**10.13.3.6 *Sealing of Tubes*** : When the end of a tube is not automatically sealed by virtue of its connection by welding to another member the end shall be properly and completely sealed. Before sealing, the inside of the tubes should be dry and free from loose scale.

**10.13.3.7 *Flatened Ends*** : In tubular construction the ends of tubes may be flattened or otherwise formed to provide for welded. Riveted or bolted connections provide that the methods adopted for such flattening do not injure the material. The change of sections shall be gradual.

#### **10.13.4 Hoisting and Erection**

Tubular trusses shall be hoisted and erected in position carefully, without damage to themselves, other structure, equipment and injury to workman. The method of hoisting and erection proposed to be adopted shall be got approved from the Engineer-in-charge. The

contractor shall however be fully responsible, for the work being carried out in a safe and proper manner without unduly stressing the various members. Proper equipment such as derricks, lifting tackles, winches, ropes etc. shall be used.

#### **10.13.5 Measurements**

The work as fixed in place shall be measured in running metres correct to a centimeter on their weights calculated on the basis of standard tables correct to the nearest kilogram unless otherwise specified. Weight of cleats, brackets, packing pieces bolts nuts, washers distance pieces separators diaphragm gusses (taking overall square dimensions) fish plates, etc. shall be added to the weight of respective items unless otherwise specified. No deduction shall be made for skew cuts.

#### **10.13.6 Rate**

The rate shall include the cost of labour and materials involved in all the operations described above including application of one coat of approved steel primer, i.e. red oxide zinc chrome primer conforming to IS 2074.

#### **10.14 FAN CLAMPS (Fig. 10.9)**

**10.14.1** The fan clamps shall be of the following types:

(a) Fan clamp to be fixed during the laying of R.C.C. slab, shall be of type I, as shown in (Fig. 10.9) This shall be made of 16 mm M.S. bar bent to shape with its ends hooked. The overall height of the clamps shall be made to suit the depth of slab.

(b) Fan clamps for beams shall be of type II as shown in (Fig. 10.9). It shall be similar to fan clamp, type I, except that its height shall be greater depending on the depth of the beam rib.

(c) In case low ceiling heights, circular cast iron box for ceiling fan clamp shall be fixed during the laying of R.C.C. slab and shall be as shown in (Fig. 10.9). The size of cast iron box shall be 140 mm internal dia with 73 mm height, the thickness of cast iron rim shall be 4.5 mm bottom and top lid shall be of 1.5 mm thick M.S. sheet, with its top surface hacked so as to ensure proper bonding with the concrete. The lids shall be screwed into the cast iron box by means of 3.3 mm dia round head screws one each at the corners. The box can be of M.S. sheet, the thickness of side walls can be reduced to 3 mm without effecting inner dia of the box. The fan clamp shall be made of 12mm dia M.S. bar bent to shape with its ends bent as per drawing.

#### **10.14.2 Fixing**

Holes for inserting the fan clamps in the positions shown in the drawing or as instructed by the Engineer-in-charge shall be made in the shuttering after the latter has been fixed in position. After steel reinforcement is tied, fan clamps shall be fixed with their loops truly vertical and at the correct depth from the under-side of the slab or beam. The hooked arms and the loop shall be tied to the reinforcement, either directly or through cut pieces of M.S. bars with annealed steel wire 1.6 mm or 1.00 mm thick. The clamp shall neither be disturbed out of position during concreting nor shall they be bent out of shape when shuttering of slabs or beams is removed. The exposed portion of loops of the clamps shall be given two or more coats of paint, including priming coat, of approved steel primer as ordered by the Engineer-in-charge.

#### **10.14.3 Measurements**

Clamps of type I and 3 shall be counted in numbers. Fan clamps type II, shall be counted and paid for under fan clamps type I, but they shall in addition be paid for their extra height as determined by the depth of the beam.

#### **10.14.4 Rate**

The rate per fan clamps shall include the cost of labour and materials involved in all the operations described above. In the case of type I and 3 clamps, the rate shall apply irrespective of the thickness of the slabs.

#### **10.15 M.S. HOLLOW RECTANGULAR DOOR FRAMES (I-TYPE SECTION)**

##### **10.15.1 Materials**

Steel door frames shall be manufactured from commercial mild steel sheet of 1.60 mm thickness, conforming to IS 2062 and 4351. Steel door frames shall be made in the profiles as per drawings and/or as directed by the Engineer-in-charge.

### **10.15.2 Construction**

Each door frame shall consist of hinge jamb, lock jamb, head and if required angle threshold. These shall be welded or rigidly fixed together by mechanical means. Where no angle threshold is required, temporary base tie shall be screwed to the feet of frames in order to form a rigid unit. Where so specified base ties shall be pressed mild steel 1.60 mm thick adjustable to suit floor thickness of 35 or 40 mm and removable, or alternatively, threshold of mild steel angle of section 50 x 25 mm, minimum shall be provided for external doors frames.

### **10.15.3 Fabrication**

The M.S hollow rectangular steel door frames shall be got fabricated in an approved workshop as approved by the Chief Engineer.

**10.15.3.1 Fixing Lugs :** There shall be three adjustable lugs with split end tail to each jamb. The head of the fixing lug shall be 120 mm long and made up flat steel strip 25 mm wide and 1.60 mm thick.

**10.15.3.2 Hinges** 100 mm mild steel butt hinges shall be used. Floor door frames 80 cm wide and under, three hinges shall be rigidly fixed to one jamb and for frames of door above 80 cm wide, four hinges shall be rigidly fixed to one jamb, if it is single shutter. Where the height of door shutter exceeds 2.15 metres, one additional hinge shall be provided for every 0.5 m or part thereof of the additional height. In all cases the hinges shall be so fixed that the distance from the inside of the head rebate to the top of the upper hinge is 20 cm and the distance from the bottom of the door frame to the bottom of the bottom hinge is also kept about 200 mm. The middle hinges shall be at equal distance from lower and upper hinges or as agreed to between the purchaser and the supplier. Hinges shall be made of steel 2.5 mm thick with zinc coated removable pin of 6 mm diameter. The space between the two leaves of the hinge when closed shall be 3 mm and the leaf that is not welded to the frame shall have four counter sunk holes to take Number-10 cross recessed head wood screws.

**10.15.3.3 Aldrops, Sliding Bolts and Tower Bolts :** Provisions shall be made for aldrops, sliding bolts and tower bolts in the frames as per the positions given by the purchaser. Necessary mortar guards/metallic or nylon bushes shall be provided inside the frames for aldrops, sliding bolts and tower bolts.

**10.15.3.4 Lock Strike Plate :** Provision shall be made to fix lock strike plates of mortise locks or latches, complying with the relevant Indian Standards. A slot suitable for lock strike plate shall be pierced into the rebate of the frame and necessary fixing arrangement and mortar guard from the inside of the frame shall be provided.

**10.15.3.5 Shock Absorbers :** For side-hung door there shall be not less than three buffers of rubber or other suitable material inserted in holes in the rebate and one shall be located at the centre of the lock jamb of frame and other two shall be 300 mm from top and bottom of the frame. For double leaf doors two buffers shall be provided.

### **10.15.4 Finishing**

The surface of door frame shall be thoroughly cleaned, free of rust, mill –scale dirt, oil etc. either by mechanical means, for example sand or shot blasting or by chemical means such as pickling. After pretreatment of the surface one coat of approved primer i.e. red oxide zinc chrome primer conforming to IS 2074. Two coats of paints as directed by the Engineer-in-Charge shall be applied to the exposed surface.

### **10.15.5 Fixing**

Frames shall be fixed up right in plumb and plane. To avoid sag or bow in width during fixing or during construction phase, temporary struts across the width preventing sides bulging inwards may be provided. Wall shall be built solid on each side and grouted at each course to ensure solid contact with frame leaving no voids behind the frame. Three lugs shall be provided on each jamb with spacing not more than 75 cm the temporary struts should not be removed till the masonry behind the frame is set. In case screwed base tie is provided, this should be left in position till the flooring is laid when it can be removed. After pretreatment of the surface one coat of steel primer and two coats, of paint, as directed by Engineer-in-charge shall be applied to the exposed surface.

### **10.15.6 Measurements**

The length shall be measured in running metre correct to a cm. along the centre line of the frames.

### **10.15.7 Rate**

The rate shall include the cost of labour and material involved in all the operation described above including one coat of approved steel primer but excluding two coats of paint.

### **10.16 FACTORY MADE GLAZED STEEL DOORS, WINDOWS AND VENTILATORS**

**10.16.0** Specifications for this item to be same as for standard steel glazed doors, windows and ventilators as mentioned in para 10.10, except that Doors, windows and ventilators to be manufactured in a workshop, approved by the Chief engineer. Also owner of the workshop shall have a valid ISI license for manufacture of doors, windows and ventilators.

### **10.17 STEEL WORK WELDED IN BUILT-UP SECTIONS USING STRUCTURAL STEEL**

(A) In Stringers, Treads, Landing etc. of Stair cases including use of Chequered Plate wherever required

(B) In Grating, Frames, Guard Bar, Ladder, Railings, Brackete, Gates and similar work.

**10.17.1** General specifications for these items to be same as for steel work welded in built-up sections as mentioned in para 10.4 except that steel used for fabrication of these items to be of type used for structural use/purposes.

**10.17.2** Steel members used for fabricating these items to be designed structurally to withstanding the all loads to be carried out by the members during erection, fixing and functional use in designed life. Work to be executed as per structural drawings.

### **10.18 STEEL WORK WELDED IN BUILT-UP SECTIONS FOR HAND RAIL USING M.S.**

#### **TUBULAR/ERW TUBULAR PIPES AND G.I. PIPES**

**10.18.1** General specifications to be same as for steel work welded in built-up section as mentioned in para 10.4.

**10.18.2.1** Hot finished welded (HFW) Hot finished seamless (HFS) and electric resistance welded tube shall conform to IS 1161.

**10.18.2.2** G.I. pipes used for Hand rail to be conforming to IS 1239-Part I for medium grade. GI pipes to be screwed and socketed type and of required nominal bore.

**10.18.2.3** Galvanising of GI pipes shall conform to IS 4736.

**10.18.2.4** All screwed tubes and socket of GI pipes shall have pipe threads conforming to the requirements of IS 554.

**10.18.2.5** The fittings for GI pipes to be conforming to IS 1239 (Part-II).

#### **10.8.3 Measurement of Hand Rail of M.S. Tubular/E.R.W Tubular Pipes**

The work as fixed in place shall be measured in running metres correct to a centimeter and their weights calculated on the basis of standard tables correct to the nearest kilogram or actual weight whichever is less unless otherwise specified.

**Note:- For further detail refer CPWD specification volume 1, Sub Head 10.0**

## SUB HEAD : 11.0

### FLOORING

#### 11.2 CEMENT CONCRETE FLOORING

##### 11.2.1 Cement Concrete

Cement concrete of specified mix grade shall be used and it shall generally conform to the specifications described under sub head 4.0 .

##### 11.2.2 Base Concrete

**11.2.2.1** Flooring shall be laid on base concrete where so provided. The base concrete shall be provided with the slopes required for the flooring. Flooring in verandah, Courtyard, kitchens & baths shall have slope ranging from 1 : 48 to 1 : 60 depending upon location and as decided by the Engineer-in-Charge. Floors in water closet portion shall have slope of 1:30 or as decided by the Engineer-in-Charge to drain off washing water. Further, necessary drop in flooring in bath, WC, kitchen near floor traps ranging from 6 mm to 10 mm will also be provided to avoid spread of water. Necessary margin to accommodate this drop shall be made in base concrete. Plinth masonry off set shall be depressed so as to allow the base concrete to rest on it.

**11.2.2.2** The flooring shall be commenced preferably within 48 hours of the laying of base concrete. The surface of the base shall be roughened with steel wire brushes without disturbing the concrete. Immediately before laying the flooring, the base shall be wetted and a coat of cement slurry @ 2 kg of cement spread over an area of one sqm so as to get a good bond between the base and concrete floor.

**1.2.2.3** If the cement concrete flooring is to be laid directly on the RCC slab, the top surface of RCC slab shall be cleaned and the laitance shall be removed and a coat of cement slurry @ 2 kg of cement spread over an area of one sqm so as to get a good bond between the base and concrete floor.

##### 11.2.3 Thickness

The thickness of floor shall be as specified in the description of the item.

##### 11.2.4 Laying

**11.2.4.1 Panels :** Flooring of specified thickness shall be laid in the pattern including the border as given in the drawings or as directed by the Engineer-in-Charge. The border panels shall not exceed 450 mm in width and the joints in the border shall be in line with panel joints. The panels shall be of uniform size and no dimension of a panel shall exceed 2 m and the area of a panel shall not be more than 2 sqm. The joints of borders at corners shall be mitred for provision of strips.

**11.2.4.2 Laying of Flooring with Strips :** Normally cement concrete flooring shall be laid in one operation using glass/aluminium/PVC/brass strips/stainless steel strips or any other strips as required as per drawing or instructions of the Engineer-in-Charge, at the junction of two panels. This method ensures uniformity in colour of all the panels and straightness at the junction of the panels. 4 mm thick glass strips or 2 mm PVC strips or 2 mm aluminium or brass strips shall be fixed with their tops at proper level, giving required slopes. Use of glass and metallic strips shall be avoided in areas exposed to sun. Cost of providing and fixing strips shall be paid for separately.

**Concreting :** Cement concrete shall be placed in the panels and be levelled with the help of straight edge and trowel and beaten with thapy or mason's trowel. The blows shall be fairly heavy in the beginning but as consolidation takes place, light rapid strokes shall be given. Beating shall cease as soon as the surface is found covered with a thin layer of cream of mortar. The evenness of the surface shall be tested with straight edge. Surface of flooring be true to required slopes. While laying concrete, care shall be taken to see that the strips are not damaged/disturbed by the labourers. The tops of strips shall be visible clearly after finishing with cement slurry.

**11.2.4.3 Laying of Flooring without Strips :** Laying of cement concrete flooring in alternate panels may be allowed by the Engineer-in-Charge in case strips are not to be provided.

**Shuttering** : The panels shall be bounded by angle iron or flats. The angle iron/flat shall have the same depth as the concrete flooring. These shall be fixed in position, with their top at proper level giving required slopes. The surface of the angle iron or flats, to come in contact with concrete shall be smeared with soap solution or non-sticking oil (Form oil or raw linseed oil) before concreting. The flooring shall butt against the unplastered masonry wall.

**Concreting** : The concreting shall be done in the manner described under 11.2.4.2. The angle iron/ flats used for shuttering, shall be removed on the next day of the laying of cement concrete. The ends thus exposed shall be repaired, if damaged with cement mortar 1 : 2 (1 cement : 2 coarse sand) and allowed to set for minimum period of 24 hours. The alternate panels shall then be cleaned of dust, mortar, droppings etc. and concrete laid. While laying concrete, care shall be taken to see that the edges of the previously laid panels are not damaged and fresh mortar is not splashed over them. The joints between the panels should come out as fine straight lines.

### **11.2.5 Finishing**

**11.2.5.1** The finishing of the surface shall follow immediately after the cessation of beating. The surface shall be left for some time, till moisture disappears from it or surplus water can be mopped up. Use of dry cement or cement and sand mixture stiffening the concrete to absorb excessive moisture shall not be permitted. Excessive trowelling shall be avoided.

**11.2.5.2** Fresh cement shall be mixed with water to form a thick slurry and spreaded @ 2 kg of cement over an area of one sqm of flooring while the flooring concrete is still green. The cement slurry shall then be properly processed and finished smooth.

**11.2.5.3** The edges of sunk floors shall be finished and rounded with cement mortar 1:2 (1 cement : 2 coarse sand) and finished with a floating coat of neat cement.

**11.2.5.4** The junctions of floor with wall plaster, dado or skirting shall be rounded off where so specified.

**11.2.5.5** The men engaged on finishing operations shall be provided with raised wooden platform to sit on so as to prevent damage to new work.

### **11.2.6 Curing**

The curing shall be done for a minimum period of ten days. Curing shall not be commenced until the top layer has hardened. Covering with empty gunnies bag shall be avoided as the colour of the flooring is likely to be bleached due to the remnants of cement dust from the bags.

### **11.2.7 Precautions**

Flooring in lavatories and bath room shall be laid only after fixing of water closet and squatting pans and floor traps. Traps shall be plugged while laying the floors and opened after the floors are cured and cleaned. Any damage done to W.C.'s squatting pans and floor traps during the execution of work shall be made good. During cold weather, concreting shall not be done when the temperature falls below 4°C. The concrete placed shall be protected against frost by suitable covering. Concrete damaged by frost shall be removed and work redone. During hot weather, precautions shall be taken to see that the temperature of wet concrete does not exceed 38° C. No concreting shall be laid within half an hour of the closing time of the day, unless permitted by the Engineer-in-Charge. To facilitate rounding of junction of skirting, dado and floor, the skirting/dado shall be laid along with the border or adjacent panels of floor.

### **11.2.8 Measurement**

Length and breadth shall be measured before laying skirting, dado or wall plaster. No deduction shall be made nor extra paid for voids not exceeding 0.20 sqm. Deductions for ends of dissimilar materials or other articles embedded shall not be made for areas not exceeding 0.10 sqm. The flooring done either with strips (in one operation) or without strips (in alternate panels) shall be treated as same and measured together.

### **11.2.9 Rate**

The rate shall include the cost of all materials and labour involved in all the operations described above including application of cement slurry on RCC slab or on base concrete

including roughening and cleaning the surface but excluding the cost of strips which shall be paid separately under relevant item. Nosing of steps where provided shall be paid for separately in running metre. Nothing extra shall be paid for laying the floor at different levels in the same room or courtyard and rounding off edges of sunk floors. In case the flooring is laid in alternate panels, nothing extra shall be paid towards the cost of shuttering used for this purpose.

### **11.3 CEMENT CONCRETE FLOORING WITH METALLIC HARDENER TOPPING**

**11.3.0** Wherever floors are required to withstand heavy wear and tear, use of floor hardener shall be avoided as far as possible by using richer mixes of concrete, unless the use of a metallic hardener is justified on the basis of cost. Where metallic hardener topping is used, it shall be 12 mm thick.

#### **11.3.1 Metallic Hardening Compound**

The compound shall be of approved quality consisting of uniformly graded iron particles, free from non-ferrous metal particles, oil, grease sand, soluble alkaline compounds. Where so directed by the Engineer-in-Charge it shall be tested as described in Appendix A.

#### **11.3.2 Base Concrete**

It shall be as specified in 11.2.2.

#### **11.3.3 Under Layer**

Cement concrete flooring of specified thickness and mix (mentioned in item for under layer) shall be laid as under layer (11.2.1 and 11.2.4). The top surface shall be roughened with brushes while the concrete is still green and the forms/strips shall be kept projecting up 12 mm over the concrete surface, to receive the metallic hardening compound topping.

#### **11.3.4 Topping**

This shall consist of 12 mm thick layer of mix 1:2 (1 cement : 2 stone aggregate 6 mm nominal size) by volume or as otherwise specified with which metallic hardening compound is mixed in the ratio of 1 : 4 (1 metallic concrete hardener : 4 cement) by weight. Metallic hardener shall be dry mixed thoroughly with cement on a clean dry pacca platform. This dry mixture shall be mixed with stone aggregate 6 mm nominal size or as otherwise specified in the ratio of 1 : 2 (1 cement : 2 stone aggregate) and well turned over. Just enough water shall then be added to this dry mix as required for floor concrete. The mixture so obtained shall be laid in 12 mm thickness, on cement concrete floor within 2 to 4 hours of its laying. The topping shall be laid true to provide a uniform and even surface. It shall be firmly pressed into the bottom concrete so as to have good bond with it. After the initial set has started, the surface shall be finished smooth and true to slope with steel floats. The junction of floor with wall plaster, dado or skirting and finishing operations shall be dealt with as described in 11.2.5. The men engaged on finishing operations shall be provided with raised wooden platform to sit on, so as to prevent damage to new work.

**11.3.5** The specifications for curing, precautions to be taken, 'Measurements' and 'Rates' shall be as specified in 11.2.

### **11.4 CEMENT PLASTER IN RISERS OF STEPS, SKIRTING, DADO**

**11.4.0** Plaster at the bottom of wall not exceeding 30 cm in height above the floor shall be classified as skirting. It shall be flush with wall plaster or projecting out uniformly by 6 mm from the wall plaster, as specified. The work shall be preferably carried out simultaneously with the laying of floor. Its corners and junctions with floor shall be finished neatly as specified.

#### **11.4.1 Thickness**

The thickness of the plaster specified shall be measured exclusive of the thickness of key i.e. grooves or open joints in brick work. The average thickness shall not be less than the specified thickness. The average thickness should be regulated at the time of plastering by keeping suitable thickness of the gauges. Extra thickness required in rounding of corners at junctions of wall shall be ignored.

#### **11.4.2 Preparation of Wall Surface**



The joints shall be raked out to a depth of at least 15 mm in masonry walls. In case of concrete walls, the surfaces shall be roughened by hacking. The surface shall be cleaned thoroughly, washed with water and kept wet before skirting is commenced.

#### **11.4.3 Application**

Skirting with specified mortar and to specified thickness shall be laid immediately after the surface is prepared. It shall be laid along with the border or adjacent panels of floor. The joints in skirting shall be kept true and straight in continuation of the line of joints in borders or adjacent panels. The skirting shall be finished smooth with top truly horizontal and joints truly vertical except where otherwise indicated.

#### **11.4.4 Finishing**

The finishing of surface shall be done simultaneously with the borders or the adjacent panels of floor. The cement to be applied in the form of slurry for smooth finishing shall be at the rate of 2 kg of cement per litre of water applied over an area of 1 sqm. Where skirting is flush with plaster, a groove 10 mm wide and upto 5 mm deep shall be provided in plaster at the junction of skirting with plaster.

#### **11.4.5 Curing**

Curing shall be commenced on the next day of plastering when the plaster has hardened sufficiently and shall be continued for a minimum period of 7 days.

#### **11.4.6 Measurement**

Length and height shall be measured correct to a cm and its area shall be calculated in sqm correct to two places of decimals for a specified thickness. Length shall be measured as the finished length of skirting. Height shall be measured from the finished level of floor correct to 5 mm.

#### **11.4.7 Rate**

Rate shall include the cost of all materials and labour involved in all the operations described above.

### **11.5 CEMENT CONCRETE PAVEMENT IN COURTYARD AND TERRACE ETC.**

**11.5.1** Specifications described in 11.2.1, 11.2.2.1, 11.2.3, 11.2.4, 11.2.6 and 11.2.7 shall hold good as far as applicable except that :

(i) The panels shall be of uniform size and no dimension of a panel shall exceed 1.25 m and the area of panel should not exceed 1.25 sqm for the thickness of panels upto 50 mm.

(ii) Concreting shall be done in alternate panels only and no glass/asbestos strips shall be provided.

#### **11.5.2 Finishing**

The finishing of the surface shall follow immediately after the cessation of beating. The surface shall be left for some-time, till moisture disappears from it or surplus water can be mopped up. Use of dry cement or cement and sand mix on the surface to stiffen the concrete or to absorb excessive moisture shall not be permitted. Excessive trowelling shall be avoided. When the surface becomes fairly stiff, it shall be finished rough with wooden floats or where so specified chequered uniformly by pressing a piece of expanded metal of approved size.

#### **11.5.3 Measurements**

Same as 11.2.8 except that the volume will be calculated in cum nearest to two decimal places.

#### **11.5.4 Rate**

The rate shall include the cost of all materials and labour involved in all the operations described above except the base concrete below flooring which shall be paid for separately. Chequering to pattern shall be paid for separately unless otherwise specified.

### **11.15 PRESSED CERAMIC TILE FLOORING**

#### **11.15.1 Pressed Ceramic Tiles**

The tiles shall be of approved make and shall generally conform to IS 15622. They shall be flat, and true to shape and free from blisters crazing, chips, welts, crawling or other imperfections detracting from their appearance. The tiles shall be tested as per IS 13630. Classification and Characteristics of pressed ceramic tiles shall be as per IS 13712. The tiles

shall be square or rectangular of nominal size. Table 1,3,5, and 7 of IS 15622 give the modular preferred sizes and table 2,4,6 and 8 give the most common non modular sizes. Thickness shall be specified by the manufacturer. It includes the profiles on the visible face and on the rear side. Manufacturer/supplier and party shall choose the work size of tiles in order to allow a nominal joint width upto 2mm for unrectified floor tiles and upto 1mm for rectified floor tiles. The joint in case of spacer lug tile shall be as per spacer. The tiles shall conform to table10 of IS 15622 with water absorption 3 to 6% (Group BII). The top surface of the tiles shall be glazed. Glaze shall be either glossy or matt as specified. The underside of the tiles shall not have glaze on more than 5% of the area in order that the tile may adhere properly to the base. The edges of the tiles shall be preferably free from glaze. However, any glaze if unavoidable, shall be permissible on only upto 50 per cent of the surface area of the edges.

#### **11.15.2 Coloured Tiles**

Only the glaze shall be coloured as specified. The sizes and specifications shall be the same as for the white glazed tiles.

#### **11.15.3 Decorative Tiles**

The type and size of the decorative tiles shall be as follows :

##### **(i) Decorated white back ground tiles**

The size of these tiles shall be as per IS 15622.

##### **(ii) Decorated and having coloured back-ground**

The sizes of the tiles shall be as per IS 15622.

#### **11.15.4 Preparation of Surface and Laying**

**11.15.4.1** Base concrete or the RCC slab on which the tiles are to be laid shall be cleaned, wetted and mopped. The bedding for the tile shall be with cement mortar 1:4 (1 cement : 4 coarse sand) or as specified. The average thickness of the bedding shall be 20 mm or as specified while the thickness under any portion of the tiles shall not be less than 10 mm.

**11.15.4.2** Mortar shall be spread, tamped and corrected to proper levels and allowed to harden sufficiently to offer a fairly rigid cushion for the tiles to be set and to enable the mason to place wooden plank across and squat on it.

**11.15.4.3** Over this mortar bedding neat grey cement slurry of honey like consistency shall be spread at the rate of 3.3 kg of cement per square metre over an area upto one square metre. Tiles shall be soaked in water washed clean and shall be fixed in this grout one after another, each tile gently being tapped with a wooden mallet till it is properly bedded and in level with the adjoining tiles. The joints shall be kept as thin as possible and in straight lines or to suit the required pattern.

**11.15.4.4** The surface of the flooring during laying shall be frequently checked with a straight edge about 2 m long, so as to obtain a true surface with the required slope. In bath, toilet W.C. kitchen and balcony/verandah flooring, suitable tile drop or as shown in drawing will be given in addition to required slope to avoid spread of water. Further tile drop will also be provided near floor trap.

**11.15.4.5** Where full size tiles cannot be fixed these shall be cut (sawn) to the required size, and their edge rubbed smooth to ensure straight and true joints. Tiles which are fixed in the floor adjoining the wall shall enter not less than 10 mm under the plaster, skirting or dado.

**11.15.4.6** After tiles have been laid surplus cement slurry shall be cleaned off.

#### **11.15.5 Pointing and Finishing**

The joints shall be cleaned off the grey cement slurry with wire/coir brush or trowel to a depth of 2 mm to 3 mm and all dust and loose mortar removed. Joints shall then be flush pointed with white cement added with pigment if required to match the colour of tiles. Where spacer lug tiles are provided, the half the depth of joint shall be filled with polysulphide or as specified on top with under filling with cement grout without the lugs remaining exposed. The floor shall then be kept wet for 7 days. After curing, the surface shall be washed and finished clean. The finished floor shall not sound hollow when tapped with a wooden mallet.

#### **11.15.6 Measurements**

Length and breadth shall be measured correct to a cm before laying skirting, dado or wall plaster and the area calculated in square metre correct to two places of decimal. Where coves are used at the junctions, the length and breadth shall be measured between the lower edges of the coves. No deduction shall be made nor extra paid for voids not exceeding 0.20 square metre. Deductions for ends of dissimilar materials or other articles embedded shall not be made for areas not exceeding 0.10 square metre. Areas, where glazed tiles or different types of decorative tiles are used will be measured separately.

#### **11.15.7 Rate**

The rate for flooring shall include the cost of all materials and labour involved in all the operations described above, For tiles of sizes upto 0.16 sqm. unless otherwise specified in the description of the item. Nothing extra shall be paid for the use of cut (sawn) tiles in the work. Extra over and above the normal rate for white tiles shall be paid where coloured or any other type of decorative tiles have been used.

#### **11.16 PRESSED CERAMIC TILE FLOORING (VITRIFIED TILE FLOORING)**

**11.16.1** Operations as described in 11.15.1 to 11.15.6 shall be followed except the tiles shall conform to Table 12 of IS 15622 (Tiles with water absorption  $E \leq 0.08$  per cent Group BIa) and the joint thickness in flooring shall not be more than 1mm.

#### **11.16.2 Rate**

The rate for flooring shall include the cost of all materials and labour involved in all the operations described above. Nothing extra shall be paid for the use of cut (sawn) tiles in the work.

#### **11.17 FIXING OF TILE FLOORING WITH CEMENT BASED HIGH POLYMER MODIFIED QUICK SET ADHESIVE (WATER BASED)**

**11.17.1** When tile flooring is to be laid over the existing flooring without dismantling old flooring it can be laid with adhesive. The old flooring shall be thoroughly cleaned and checked for undulations, if any shall be rectified with cement mortar 1:3 (1 cement: 3 coarse sand). Old cement concrete surface shall be hacked and cleaned off to have proper bond with the old surface.

**11.17.2** High polymer modified quick set tile adhesive (conforming to IS 15477) shall be thoroughly mixed with water and a paste of zero slump shall be prepared so that it can be used within 1.5 to 2 hours. It shall be spread over an area not more than one sqm at one time. Average thickness of adhesive shall be 3 mm The adhesive so spread shall be combed using suitable trowel. Tiles shall be pressed firmly in to the position with slight twisting action checking it simultaneously to ensure good contact gently being tapped with wooden mallet till it is properly backed with adjoining tiles. The tiles shall be fixed within 20 minutes of application of adhesive. The surplus adhesive from the joints, surface of the tiles shall be immediately cleaned.

**11.17.3** The surface of the flooring shall be frequently checked during laying with straight edge of above 2m long so as to attain a true surface with required slope.

**11.17.4** Where spacer lugs tiles are provided these shall be filled with grout with lugs remaining exposed.

**11.17.5** Where full size tile can not be fixed these shall be cut (sawn) to the required size and edges rubbed smooth to ensure straight and true joints. Tiles which are fixed in floor adjoining to wall shall enter not less than 10 mm under plaster, skirting or dado.

**11.17.6** Finishing: para 11.15.5 shall apply.

**11.17.7** Measurements: para 11.15.6 shall apply.

#### **11.17.8 Rate**

Provisions of para 11.15.7 and 11.16.2 shall apply.

#### **11.18 PRESSED CERAMIC TILES IN SKIRTING AND DADO**

**11.18.1** The tiles shall be of approved make and shall generally conform to IS 15622. The tiles shall be pressed ceramic covered by a glaze thoroughly matured and fitted to the body. The tiles shall be sound, true to shape, flat and free from flaws and other manufacturing defects affecting their utility. The top surface of the tiles shall be glazed. The underside of

the tiles shall not have glaze on more than 5% of the area in order that the tile may adhere properly to the base. The edges of the tiles shall be free from glaze, however, any glaze if unavoidable shall be permissible on only upto 50 per cent of the surface area of edges. The glaze shall be free from welts, chips, craze, specks, crawlings or other imperfections detracting from the appearance when viewed from a distance of one metre. The glaze shall be either glossy or matt as specified. The glaze shall be white in colour except in the case of coloured tiles when colours shall be specified by the Engineer-in-Charge. There may be more than one colour on a tile.

#### **11.18.1 (a) Dimensions and Tolerances**

Glazed pressed ceramic tiles shall be made square or rectangular in sizes Table 1, 3, 5 & 7 of IS 15622 give the modular sizes and table 2, 4, 6 & 8 of IS 15622 gives the sizes of non modular tiles. The tiles shall conform to IS 15622 for dimensional tolerance, physical and chemical properties. Half tiles for use as full tiles shall have dimensions which shall be such as to make the half tiles when jointed together (with 1 mm joint) match with dimensions of full tiles. Tiles may be manufactured in sizes other than those specified. above. The thickness of the tiles shall be 5 mm or 6 mm or as specified. The dimensions of fittings associated with the glazed tiles namely cover base, round edge tile, angles corner cups, ridge and legs, cronices and capping beads shall be of the shape and dimensions as required and the thickness of fittings shall be the same as the thickness of tiles given above.

#### **11.18.2 Preparation of Surfaces**

The joints shall be raked out to a depth of at least 15 mm in masonry walls. In case of concrete walls, the surface shall be hacked and roughened with wire brushes. The surface shall be cleaned thoroughly, washed with water and kept wet before skirting is commenced.

#### **11.18.3 Laying**

12 mm thick plaster of cement mortar 1:3 (1 cement : 3 coarse sand) mix of as specified shall be applied and allowed to harden. The plaster shall be roughened with wire brushes or by scratching diagonal at closed intervals. The tiles should be soaked in water, washed clean, and a coat of cement slurry applied liberally at the back of tiles and set in the bedding mortar. The tiles shall be tamped and corrected to proper plane and lines. The tiles shall be set in the required pattern and jointed. The joints shall be as fine as possible. Top of skirting or dado shall be truly horizontal and joints truly vertical except where otherwise indicated. Odd size/cut size of tile shall be adjusted at bottom to take care of slope of the flooring. Skirting and dado shall rest on the top of the flooring. Where full size tiles cannot be fixed these shall be cut (sawn) to the required size and their edges rubbed smooth. Skirting /dado shall not project from the finished "surface of wall" by more than the tile thickness, undulations if any shall be adjusted in wall.

#### **11.18.4 Curing and Finishing**

The joints shall be cleaned off the grey cement grout with wire/coir brush or trowel to a depth of 2 mm to 3 mm and all dust and loose mortar removed. Joints shall then be flush pointed with white cement added with pigments if required to match the colour of tiles. The work shall then be kept wet for 7 days. After curing, the surface shall be washed and finished clean. The finished work shall not sound hollow when tapped with a wooden mallet.

#### **11.18.5 Measurements**

Length shall be measured correct to a cm. Height shall be measured correct to a cm in the case of dado and 5 mm in the case of riser and skirting. The area shall be calculated in square metre, correct to two places of decimal. Length and height shall be measured along the finished face of the skirting or dado including curves where specials such as coves, internal and external angles and beads are used. Where cornices are used the area of dado shall be measured excluding the cornices. Nothing extra will be paid for cutting (sawn) the tiles to sizes. Areas where coloured tiles or different types of decorative tiles are used will be measured separately to be paid extra over and above the normal rate for white tiles.

#### **11.18.6 Rates**

The rate shall include the cost of all material and labour involved in all the operations described above, for tiles of sizes upto 0.14 sqm. unless otherwise specified in the description of the item. The specials such as coves, internal and external angles and beading shall be measured and paid for separately. The rate shall not include cost of cornices which shall be measured and paid for in running meters separately.

## **11.21 KOTA STONE FLOORING**

### **11.21.1 Kota Stone Slabs**

The slabs shall be of selected quality, hard, sound, dense and homogeneous in texture free from cracks, decay, weathering and flaws. They shall be hand or machine cut to the requisite thickness. They shall be of the colour indicated in the drawings or as instructed by the Engineer-in-Charge. The slabs shall have the top (exposed) face polished before being brought to site, unless otherwise specified. The slabs shall conform to the size required. Before starting the work the contractor shall get the samples of slabs approved by the Engineer-in-Charge.

### **11.21.2 Dressing**

Every slab shall be cut to the required size and shape and fine chisel dressed on the sides to the full depth so that a straight edge laid along the side of the stone shall be in full contact with it. The sides (edges) shall be table rubbed with coarse sand or machine rubbed before paving. All angles and edges of the slabs shall be true, square and free from chippings and the surface shall be true and plane. The thickness of the slab after it is dressed shall be 20, 25, 30 or 40 mm as specified in the description of the item. Tolerance of  $\pm 2$  mm shall be allowed for the thickness. In respect of length and breadth of slabs Tolerance of  $\pm 5$  mm for hand cut slabs and  $\pm 2$  mm for machine cut slabs shall be allowed.

### **11.21.3 Preparation of Surface and Laying**

The specification shall be as described in 11.19.3 except that the edges of the slabs to be jointed shall be buttered with grey cement, with admixture of pigment to match the shade of the slab. The thickness of the joints should be minimum as possible. In any location, it shall not exceed 1 mm.

### **11.21.4 Polishing and Finishing**

The specifications shall be as described in 11.19.3 except that (a) first polishing with coarse grade carborundum stone shall not be done, (b) cement slurry with or without pigment shall not be applied on the surface before polishing.

### **11.21.5 Measurements and Rates**

These shall be as described in paras 11.19.5 and 11.19.6.

## **11.22 KOTA STONE IN RISERS OF STEPS, SKIRTING AND DADO**

**11.22.1** Kota Stone Slabs and Dressing shall be as specified in 11.21.1 and 11.21.2 except that the thickness of the slabs shall be 25 mm or as specified in the description of the item. The slabs may be of uniform size if required.

**11.22.2** Preparation of surface shall be as specified in 11.20.2.

**11.22.3** Laying shall be as specified in 11.20.3 except that the joints of the slabs shall be set in grey cement mixed with pigment to match the shade of the slabs.

**11.22.4** Curing, Polishing and Finishing shall be as specified in 11.20.4 except that first polishing with coarse grade carborundum stone shall not be done.

### **11.22.5 Measurements**

Length shall be measured along the finished face of riser, skirting or dado correct to a cm. Height shall be measured from the finished level of tread of floor to the top (the underside of tread in the case of steps). This shall be measured correct to a mm in the case of risers of steps and skirting and correct to a cm in the case of dado. The area shall be calculated in square metre correct to two places of decimal. Lining of pillars etc. shall also be measured under this item.

### **11.22.6 Rate**

The rate shall include the cost of all materials and labour involved in all the operations described above.

**Note:- For further detail refer CPWD specification volume 1, Sub Head 11.0**

## SUB HEAD : 12.0 ROOFING

### 12.0 TERMINOLOGY

#### 12.0.1 Accessories

Purpose made fittings, such as apron flashing pieces, barge boards, bottom glazing flashing, corner piece (corner flashing), eaves filler pieces, expansion joints, hip capping, hip tile or cap, ridge capping, ridge finials, roof lights, ventilators, with which the roof is furnished.

#### 12.0.2 Eaves

The lower edge of the inclined roof.

#### 12.0.3 Finial

A decorative fitting used at the Junction of ridges and hips to form a water proof covering and at the top of conical, pyramidal, or dome roofs.

#### 12.0.4 Flashing

A strip of impervious material, usually metal used to exclude water from the junction between a roof covering and another part of the structure.

#### 12.0.5 Gable

Part of wall above the general eaves level at tie end of ridged or partially hipped roof.

#### 12.0.6 Gutter

Any form of roof water channel.

#### 12.0.7 Hip

The outer angle (more than 180 degree) formed by the inclined ridge between two intersecting roof slopes.

#### 12.0.8 Pitch

**12.0.8.1** The angle of inclination with the horizontal of the rafters or substructure surface on which the roof coverings are laid.

**12.0.8.2** In patent glazing, the angle at which the plane of a stretch of glazing is inclined to the horizontal.

#### 12.0.9 Pitched Roof

A roof the pitch of which is greater than 10 degree to the horizontal.

#### 12.0.10 Ridge

The horizontal inter-section at the apex of the two rising roof surfaces inclined in opposite directions.

#### 12.0.11 Valley

The re-entrant angle formed by the inter-section of two inclined roof surfaces.

#### 12.0.12 Verge

Free edge of a roof surface ending at a gable.

### 12.1 CORRUGATED GALVANISED STEEL SHEET ROOFING

#### 12.1.1 C.G.S. Sheets

These shall be of the thickness specified in the description of the item and shall conform to IS 277. The sheets shall be of 275 grade of coating (See Appendix-A) unless otherwise specified in the description of item. The sheets shall be free from cracks, split edges, twists, surface flaws etc. They shall be clean, bright and smooth. The galvanizing shall be non-injured and in perfect condition. The sheets shall not show signs of rust or white powdery deposits on the surface. The corrugations shall be uniform in depth and pitch and parallel with the side.

#### 12.1.2 Purlins

Purlins of the specified material or M.S. rolled sections of requisite size shall be fixed over the principal rafters. These shall not be spaced at more than the following distances. (Table 12.1)

**TABLE 12.1**

<i>Thickness of C.G.S. sheet</i>	<i>Maximum spacing of purlins</i>
1.00 mm	2.00 metre
0.80 mm	1.80 metre
0.63 mm	1.60 metre

The top surfaces of the purlins shall be uniform and plane. They shall be painted before fixing on top. Embedded portions of wooden purlins shall be coal tarred with two coats.

**12.1.3 Slope**

Roof shall not be pitched at a flatter slope than 1 vertical to 5 horizontal. The normal pitch adopted shall usually be 1 vertical to 3 horizontal.

**12.1.4 Laying and Fixing**

**12.1.4.1** The sheets shall be laid and fixed in the manner described below, unless otherwise shown in the working drawings or directed by the Engineer-in-Charge.

**12.1.4.2** The sheets shall be laid on the purlins to a true plane, with the lines of corrugations parallel or normal to the sides of the area to be covered unless otherwise required as in special shaped roofs.

**12.1.4.3** The sheets shall be laid with a minimum lap of 15 cm at the ends and 2 ridges of corrugations at each side. The above minimum end lap of 15 cm shall apply to slopes of 1 vertical to 2 horizontal and steeper slopes. For flatter slopes the minimum permissible end lap shall be 20 cm. The minimum lap of sheets with ridge, hip and valley shall be 20 cm measured at right angles to the line of the ridge, hip and valley respectively. These sheets shall be cut to suit the dimensions or shapes of the roof, either along their length or their width or in a slant across their lines of corrugations at hips and valleys. They shall be cut carefully with a straight edge chisel to give a smooth and straight finish.

**12.1.4.4** Lapping in C.G.S. sheets shall be painted with a coat of approved steel primer and two coats of painting with approved paint suitable for G.S. sheet, before the sheets are fixed in place.

**12.1.4.5** Sheets shall not generally be fixed into gables and parapets. They shall be bent up along their side edges close to the wall and the junction shall be protected by suitable flashing or by a projecting drip course, the later to cover the junction by at least 7.5 cm.

**12.1.4.6** The laying operation shall include all scaffolding work involved.

**12.1.4.7** Sheets shall be fixed to the purlins or other roof members such as hip or valley rafters etc. with galvanised J or L hook bolts and nuts, 8 mm diameter, with bitumen and G.I. limpet washers or with a limpet washer filled with white lead as directed by the Engineer-in-Charge. While J hooks are used for fixing sheets on angle iron purlins, and L hooks are used for fixing the sheet to R.S. joists, timber or precast concrete purlins. The length of the hook bolt shall be varied to suit the particular requirements. The bolts shall be sufficiently long so that after fixing they project above the top of the nuts by not less than 10 mm. The grip of J or L hook bolt on the side of the purlin shall not be less than 25 mm. There shall be a minimum of three hook bolts placed at the ridges of corrugations in each sheet on every purlin and their spacing shall not exceed 30 cm. Coach screws shall not be used for fixing sheets to purlins.

**12.1.4.8** The galvanised coating on J or L hooks, and bolts shall be continuous and free from defects such as blisters, flux stains, drops, excessive projections or other imperfections which would impair serviceability. The galvanised coating should conform to IS 1367 (Pt. XIII) The mass of coating per square meter of the surface shall be as under:

**Mass and Equivalent Thickness of Coating**

<i>Minimum Mass (g/m<sup>2</sup>)</i>	<i>Average Thickness (µm)</i>	<i>Minimum Mass (g/m<sup>2</sup>)</i>	<i>Individual Thickness (µm)</i>
375	54	300	43

**12.1.4.9** Where slopes of roofs are less than 21.5 degrees (1 vertical to 2.5 horizontal) sheets shall be joined together at the side laps by galvanised iron bolts and nuts 25 × 6 mm size, each bolt provided with a bitumen and a G.I. limpet washer or a G.I. limpet washer filled with white lead. As the overlap at the sides extends to two corrugations, these bolts shall be placed zig-zag over the two overlapping corrugations, so that the ends of the overlapping sheets shall be drawn tightly to each other. The spacing of these seam bolts shall not exceed 60 cm along each of the staggered rows. Holes for all bolts shall be drilled and not punched in the ridges of the corrugations from the underside, while the sheets are on the ground.

### **12.1.5 Wind Tie**

Wind ties shall be of 40 x 6 mm flat iron section or of other size as specified. These shall be fixed at the eaves of the sheets. The fixing shall be done with the same hook bolts which secure the sheets to the purlins. The ties shall be paid for separately unless described in the item of roofing.

### **12.1.6 Finish**

The roof when completed shall be true to lines, and slopes and shall be leak proof.

### **12.1.7 Measurements**

**12.1.7.1** The length and breadth shall be measured correct to a cm. Area shall be worked out in sqm correct to two places of decimal.

**12.1.7.2** The superficial area of roof covering shall be measured on the flat without allowance for laps and corrugations. Portion of roof covering overlapping the ridge or hip etc. shall be included in the measurements of the roof.

**12.1.7.3** Roof with curved sheets shall be measured and paid for separately. Measurements shall be taken on the flat and not girthed.

**12.1.7.4** No deduction in measurement shall be made for opening upto 0.4 sqm and nothing extra shall be allowed for forming such openings. For any opening exceeding 0.4 sqm in area, deduction in measurements for the full opening shall be made and in such cases the labour involved in making these openings shall be paid for separately. Cutting across corrugation shall be measured on the flat and not girthed. No additions shall be made for laps cut through.

### **12.1.8 Rate**

The rate shall include the cost of all the materials and labour involved in all the operations described above including a coat of approved steel primer and two coats of approved steel paint on overlapping of C.G.S. sheets. This includes the cost of roof sheets, galvanised iron J or L hooks, bolts and nuts, galvanised iron seam bolts and nuts, bituminous and galvanised iron limpet washers etc.

## **12.2 RIDGES AND HIPS OF PLAIN GALVANISED STEEL SHEETS**

### **12.2.1 Ridges and Hips**

Ridges and hips of C.G.S. roof shall be covered with ridge and hip sections of plain G.S. sheet with a minimum lap of 20 cm on either side over the C.G.S. sheets. The end laps of the ridges and hips and between ridges and hips shall also be not less than 20 cm. The ridges and hips shall be of 60 cm overall width plain G.S. sheet, 0.6 mm or 0.8 mm thick as given in the description of the item and shall be properly bent in shape.

### **12.2.2 Fixing**

**12.2.2.1** Ridges shall be fixed to the purlins below with the same 8 mm dia G.I. hook bolts and nuts and bitumen and G.I. limpet washers which fix the sheets to the purlins.

**12.2.2.2** Similarly, hips shall be fixed to the roof members below such as purlins, hip and valley rafters with the same 8 mm dia G.I. hook bolts and nuts and bitumen and G.I. limpet washers which fix the sheets to those roof members. At least one of the fixing bolts shall pass through the end laps of ridges and hips, on either side. If this is not possible extra hook bolts shall be provided.

**12.2.2.3** The end laps of ridges and hips shall be joined together with C.G.S sheet by galvanised iron seam bolts 25 x 6 mm size each with a bitumen and G.I. washer or white lead as directed by the Engineer-in-Charge. There shall be at least two such bolts in each end lap.

**12.2.2.4** Surface of C.G.I. sheets of ridge and hip sections and the roofing sheets which overlap each other shall be painted with a coat of approved primer and two coats of approved paint suitable for painting G.S. Sheets before they are fixed in place.

### **12.2.3 Finish**

The edges of the ridges and hips shall be straight from end to end and their surfaces should be plane and parallel to the general plane of the roof. The ridges and hips shall fit in squarely on the sheets.

### **12.2.4 Measurement**



The measurements shall be taken for the finished work in length along the centre line of ridge or hip, as the case may be, correct to a cm. The laps in ridges and hips and between ridges and hips shall not be measured.

#### **12.2.5 Rate**

The rate shall include the cost of all labour and materials specified above, including painting, cost of seam bolts and any extra G.I. hook bolts, nuts and washers, required.

### **12.3 VALLEY AND FLASHING OF PLAIN GALVANISED STEEL SHEETS**

#### **12.3.1 Valley and Flashing**

Valley shall be 90 cm wide overall plain G.S. sheet 1.6 mm thick or other size as specified in the item bent to shape and fixed. They shall lap with the C.G.S. sheets not less than 25 cm width on other side. The end laps of valley shall also be not less than 25 cm. Valley sheets shall be laid over 25 mm thick wooden boarding if so required. Flashing shall be of plain G.S. sheet of 40 cm overall width 1.25 mm thick or 1.00 mm thick as specified in the item bent to shape and fixed. They shall lap not less than 15 cm over the roofing sheets. The end laps between flashing pieces shall not be less than 25 cm.

#### **12.3.2 Laying and Fixing**

Flashing and valley sheets shall be fixed to the roof members below, such as purlins and valley rafters with the same 8 mm dia G.I. hook bolts and nuts and bitumen and G.I. limpet washers which fix the sheets to those roof members. At least one of the fixing bolts shall pass through the end laps of the valley pieces on other side. If this is not possible extra hook bolts shall be provided. The free end of flashing shall be fixed at least 5 cm inside masonry with the mortar of mix 1: 3 (1 cement: 3 coarse sand). Refer Fig. 12.3.

**12.3.3** Surface of G.S. sheets under overlaps shall be painted with a coat of approved primer and two coats of approved paint suitable for painting G.S. sheets.

#### **12.3.4 Finish**

The edges of valley and flashing should be straight from end to end. The surfaces should be true and without bulges and depressions.

#### **12.3.5 Measurements**

The length of the valleys and flashing shall be measured for the finished work correct to a cm. The laps along the length of the valley or flashing pieces, including the portion embedded in masonry, shall not be measured.

#### **12.3.6 Rates**

The rate for valleys, shall be for all the labour and materials specified above, including painting, cost of seam bolts and the cost of requisite G.I. hook bolts, nuts and washers required over and above those needed for connecting the roof sheets to the roof members. The rate for valleys shall exclude the cost of boarding underneath which shall be paid for separately. The rate for flashing shall be for all the labour and materials specified above, and shall include the cost of painting and mortar for fixing in wall.

### **12.4 GUTTERS MADE OF PLAIN GALVANISED STEEL SHEETS (FIG. 12.2)**

#### **12.4.1 Gutters**

Gutter shall be fabricated from plain G.S. Sheets of thickness as specified in the item. Eaves gutters shall be of the shape and section specified in the description of the item. The overall width of the sheet referred to therein shall mean the peripheral width of the gutter including the rounded edges. The longitudinal edges shall be turned back to the extent of 12 mm and beaten to form a rounded edge. The ends of the sheets at junctions of pieces shall be hooked into each other and beaten flush to avoid leakage.

#### **12.4.2 Slope**

Gutter shall be laid with a minimum slope of 1 in 120.

#### **12.4.3 Laying and Fixing**

**12.4.3.1** Gutter shall be supported on and fixed to M.S. flat iron brackets bent to shape and fixed to the requisite slope. The maximum spacing of brackets shall be 1.20 metres.

**12.4.3.2** Where these brackets are to be fixed to the sides of rafters, they shall be of 40 × 3 mm section bent to shape and fixed rigidly to the sides of rafters with 3 Nos. 10 mm dia

bolts, nuts and washers. The brackets shall overlap the rafter not less than 30 cm and the connecting bolts shall be at 12 cm centres.

**12.4.3.3** Where the brackets are to be fixed to the purlins, the brackets shall consist of 50 × 3 mm M.S. flat iron bent to shape with one end turned at right angle and fixed to the purlin face with 2 Nos. of 10 mm dia bolts nuts and washers. The bracket will be stiffened by provision of 50 × 3 mm. M.S. flat whose over hung portion bent to right angle shape with its longer leg connected to the bracket with 2 Nos. 6 mm dia M.S. bolts, nuts and washers and its shorter leg fixed to face of purlin with 1 No. 10 mm dia, bolt, nut and washer. The over hang of the vertical portion of the bracket from the face of the purlin shall not exceed 22.5 cm with this arrangement. The spacing of the brackets shall not exceed 1.20 metres.

**12.4.3.4** The gutter shall be fixed to the brackets with 2 Nos. G.I. bolts and nuts 6 mm dia, each fitted with a pair of G.I. and bitumen washers. The connecting bolts shall be above the water line of the gutters.

**12.4.3.5** For connection to down take pipes, a proper drop end or funnel shaped connecting piece shall be made out of G.S. sheet of the same thickness as the gutter and riveted to the gutter, the other end tailing into the socket of the rain-water pipe. Wherever necessary stop ends, angles etc., should be provided.

#### **12.4.4 Finish**

The gutters when fixed shall be true to line and slope and shall be leakproof.

#### **12.4.5 Measurements**

Measurements shall be taken for the finished work along the centre line of the top width of the gutter connection to a cm. The hooked lap portion in the junctions and gutter lengths shall not be measured. The number of brackets which are fixed to purlins with stiffener flats should be measured.

#### **12.4.6 Rate**

The rate shall include the cost of all labour and materials specified above, including all specials such as angles, junctions, drop ends or funnel shaped connecting pieces, stop ends etc., flat iron brackets and bolts and nuts required for fixing the latter to the roof members. Brackets of 50 × 3 mm flats fixed to purlins with stiffener flats will be paid extra.

### **12.13 CEMENT CONCRETE GOLA (FIG. 12.7)**

#### **12.13.1 Cement Concrete**

The specifications for concrete shall be the same as described in subhead 4.0 of concrete work.

#### **12.13.2 Gola**

A chase of 75 mm wide and 75 mm deep shall be cut in the parapet wall just above the junction of mud phuska or lime concrete with parapet wall and it shall be filled with cement concrete 1:2:4 (1 cement : 2 coarse sand : 4 stone aggregate 10 mm and down gauge) the external face finish with a slope of 1 : 0.75 and the exposed surface of the gola shall be plastered with cement mortar 1 : 3 (1 cement : 3 fine sand). Expansion joint at every 3.5 to 4.5 metres shall be provided and filled with bitumen filler. The bitumen filler shall be prepared by mixing bitumen, cement and coarse sand in the ratio of 80 : 1 : 0.25 (80 kg of hot bitumen : 1 kg of cement and 0.25 cum of coarse sand).

#### **12.13.3 Curing**

The finished surface shall be cured for at least 7 days.

#### **12.13.4 Measurements**

The length of the finished gola shall be measured at its junction with the wall face correct to a cm. No deduction shall be made in measurements for gaps for water outlets.

#### **12.13.5 Rate**

The rate shall include the cost of all materials and labour involved in all the operations described above including the cost of bitumen filler in expansion joint. The rate includes for all turnings and roundings at all the corners and risers.

### **12.14 KHURRAS (FIG. 12.7)**

**12.14.0** The khurras shall be constructed before the brick masonry work in parapet wall is taken up and it shall be of size 45 cm x 45 cm unless otherwise specified in the description

of the item and shall be made of cement concrete 1:2:4 mix (1 cement : 2 coarse sand : 4 graded stone aggregate 20 mm nominal size) or other mix as stipulated in the description of the item.

#### **12.14.1 Laying**

**12.14.1.1** A PVC sheet of size 1 m x 1 m x 400 micron (alternatively, aluminium foil of 32 SWG) shall be laid under the khurra and then cement concrete shall be laid over it to average thickness of 50 mm with its top surface lower than the level of adjoining roof surface by not less than 50 mm.

**12.14.1.2** The concrete shall be laid to a size greater than the stipulated size of the khurra in such a way that the adjoining terracing shall overlap the concrete on its three edges by not less than 7.5 cm. The concrete will slope uniformly from the edges to the outlet, the slope being as much as possible and in no case less than 20 mm cement concrete at the outlet. The concrete shall be continued at the same slope through the width of the wall into the outlet opening to ensure a water tight joint.

**12.14.1.3** The khurras and the sides of the outlet shall then be rendered with 12 mm coat of cement plaster 1:3 mix (1 cement : 3 coarse sand) or other mix as stipulated in the description of the item. This shall be done when the concrete is still green and shall be finished. The sides of the khurras and sides of the outlet opening shall be well rounded. The size of the finished outlet opening shall be 10 cm wide and by 20 cm high or as directed by the Engineer-in-Charge.

**12.14.1.4** In cases where rain water is to be disposed off through rain water pipes, iron grating shall be provided at the outlet as a safeguard against choking, if so directed by the Engineer-in-Charge. Iron gratings, shall be of overall size 20 × 25 cm. with an outer frame of 15 × 3 mm M.S. flat to which 4 Nos M.S. bars of 10 mm dia shall be welded in a vertical direction keeping equal clear spacing of 2.5 cm. or as directed by the Engineer in Charge.

#### **12.14.2 Measurements**

Khurras shall be counted in numbers.

#### **12.14.3 Rate**

The rate is for each completed khurra of the specified size and is inclusive of the cost of all materials and labour in forming the khurras and outlet opening as described above, except for iron gratings which shall be paid for separately.

### **12.22 RAIN WATER SPOUTS**

**12.22.0** The sectional area of rain water spouts provided shall be generally at the rate of 1 square cm per 70 to 80 square decimetre of roof area drained. However in locations subject to excessive and high intensities of rainfalls, the area of spouts provided may be suitably increased to suit local conditions. No spout shall be less than 80 mm in diameter. The spacing of spouts shall be arranged to suit the position of openings in the wall.

### **12.26 UNPLASTICISED POLYVINYL CHLORIDE PIPES AND FITTINGS**

#### **12.26.1 UPVC Pipes**

Pipes shall conform to Type A pipes of IS 13592. The internal and external surfaces of the pipes shall be smooth and clean and free from groovings and other defects. The end shall be clearly cut and shall be square with the axis of the pipe. The end may be chamfered on the plain sides. Slight shallow longitudinal grooves or irregularities in the wall thickness shall be permissible provided the wall thickness remains within the permissible limit.

#### **12.26.2 Colour of Pipe**

Surface colour of the pipes shall be dark shade of grey or as specified .

#### **12.26.3 Marking**

Each pipe shall be clearly and indelibly marked with the following informations at intervals not more than 3 meter.

- (a) Manufacturer's name or trade mark.
- (b) Nominal outside dia of pipe.
- (c) Type 'A'
- (d) Batch number.

#### **12.27.4 Dimensions**

**12.26.4.1 Diameter and Wall Thickness:** Mean outside diameter, outside diameter at any point and wall thickness for type –A manufactured plain or with socket shall be as given in Table- 1 of IS 13592. UPVC rain water pipes shall be of the dia, specified in the description of the item and shall be in nominal lengths of 2,3,4 or 6 metres either plain or with sliding/grooved socket unless shorter lengths are required at junctions with fittings. Tolerances on specified length shall be + 10 mm and – 0 mm.

**12.26.5 Fixing and Jointing**

Pipes shall be either fixed on face of wall or embedded in masonry as required in the description of the item. Plain pipes shall be secured to the walls at all joints with PVC Pipes clips by means of 50 x 50 x 50 mm hard wood plugs, screwed with M.S. screws of required length i/c cutting brick work and fixing in cement mortar 1:4 (1 cement : 4 coarse sand ). The clips shall be kept about 25 mm clear off finished face of wall, so as to facilitate cleaning of pipes. Pipes shall be fixed perfectly vertical or to the lines as directed. The pipes shall be fitted to fittings with seal ring conforming to IS 5382 allowing 10 mm gap for thermal expansion.

**12.26.6 Installation in Wall/Concrete**

The walls/concrete slots should allow for a stress free installation. Pipes and fittings to be inserted into the slots without a cement base have to be applied first with a thin coat of PVC solvent cement followed by sprinkling of dry sand (medium size). Allow it to dry. The process gives a sound base for cement fixation. This process is repeated while joining PVC material to CI/AC materials.

**12.26.7 Fittings**

Fittings used shall be of the same make as that of the PVC pipes Injection moulded or fabricated by the manufacturer and shall have a minimum wall thickness of 3.2 mm. The fittings shall be supplied with grooved socketted ends with square grooves and provided with Rubber Gasket conforming to IS 5382. The plain ends of the fittings should be chamfered. The fittings shall be joined with the help of Rubber lubricant. The details of fittings refer IS 13592.

**12.26.8 Measurements**

The fittings shall be measured by numbers. The pipes shall be measured net when fixed correct to a cm. excluding all fittings along its length.

**12.26.9 Rate**

The rate shall include the cost of all materials and labour involved in all the operations described above including jointing but excluding the supply and fixing of wall plugs and PVC clips which shall be paid for separately.

**Note :** These pipes shall be used only in shaft or unexposed location to avoid damage to these pipes due to willful act.

**Note:- For further detail refer CPWD specification volume 1, Sub Head 12.0**

**SUB HEAD : 13.0**  
**FINISHING**

**13.1 CEMENT PLASTER**

The cement plaster shall be 12 mm, 15 mm or 20 mm thick as specified in the item.

**13.1.1 Scaffolding**

For all exposed brick work or tile work double scaffolding independent of the work having two sets of vertical supports shall be provided. The supports shall be sound and strong, tied together with horizontal pieces over which scaffolding planks shall be fixed. For all other work in buildings, single scaffolding shall be permitted. In such cases the inner end of the horizontal scaffolding pole shall rest in a hole provided only in the header course for the purpose. Only one header for each pole shall be left out. Such holes for scaffolding shall, however, not be allowed in pillars/columns less than one metre in width or immediately near the skew backs of arches. The holes

left in masonry works for scaffolding purposes shall be filled and made good before plastering.

**Note :** In case of special type of brick work, scaffolding shall be got approved from Engineer-in-charge in advance.

**13.1.2 Preparation of Surface**

The joints shall be raked out properly. Dust and loose mortar shall be brushed out. Efflorescence if any shall be removed by brushing and scrapping. The surface shall then be thoroughly washed with water, cleaned and kept wet before plastering is commenced. In case of concrete surface if a chemical retarder has been applied to the form work, the surface shall be roughened by wire brushing and all the resulting dust and loose particles cleaned off and care shall be taken that none of the retarders is left on the surface.

**13.1.3 Mortar**

The mortar of the specified mix using the type of sand described in the item shall be used. It shall be as specified in Subhead 3.0. For external work and under coat work, the fine aggregate shall conform to grading IV. For finishing coat work the fine aggregate conforming to grading zone V shall be used.

**13.1.4 Application of Plaster**

**13.1.4.1** Ceiling plaster shall be completed before commencement of wall plaster.

**13.1.4.2** Plastering shall be started from the top and worked down towards the floor. All putlog holes shall be properly filled in advance of the plastering as the scaffolding is being taken down. To ensure even thickness and a true surface, plaster about 15 × 15 cm shall be first applied, horizontally and vertically, at not more than 2 metres intervals over the entire surface to serve as gauges. The surfaces of these gauged areas shall be truly in the plane of the finished plaster surface. The mortar shall then be laid on the wall, between the gauges with trowel. The mortar shall be applied in a uniform surface slightly more than the specified thickness. This shall be brought to a true surface, by working a wooden straight edge reaching across the gauges, with small upward and side ways movements at a time. Finally the surface shall be finished off true with trowel or wooden float according as a smooth or a sandy granular texture is required. Excessive troweling or over working the float shall be avoided.

**13.1.4.3** All corners, arrises, angles and junctions shall be truly vertical or horizontal as the case may be and shall be carefully finished. Rounding or chamfering corners, arrises, provision of grooves at junctions etc. where required shall be done without any extra payment. Such rounding, chamfering or grooving shall be carried out with proper templates or battens to the sizes required.

**13.1.4.4** When suspending work at the end of the day, the plaster shall be left, cut clean to line both horizontally and vertically. When recommencing the plastering, the edge of the old work shall be scrapped cleaned and wetted with cement slurry before plaster is applied to the adjacent areas, to enable the two to properly join together. Plastering work shall be

closed at the end of the day on the body of wall and not nearer than 15 cm to any corners or arrises. It shall not be closed on the body of the features such as plasters, bands and cornices, nor at the corners of arrises. Horizontal joints in plaster work shall not also occur on parapet tops and copings as these invariably lead to leakages. The plastering and finishing shall be completed within half an hour of adding water to the dry mortar. No portion of the surface shall be left out initially to be patched up later on. The plastering and finishing shall be completed within half an hour of adding water to the dry mortar.

#### **13.1.5 Thickness**

Where the thickness required as per description of the item is 20 mm the average thickness of the plaster shall not be less than 20 mm whether the wall treated is of brick or stone. In the case of brick work, the minimum thickness over any portion of the surface shall be not less than 15 mm while in case of stone work the minimum thickness over the bushings shall be not less than 12 mm.

#### **13.1.6 Curing**

Curing shall be started as soon as the plaster has hardened sufficiently not to be damaged when watered. The plaster shall be kept wet for a period of at least 7 days. During this period, it shall be suitably protected from all damages at the contractor's expense by such means as the Engineer-in-Charge may approve. The dates on which the plastering is done shall be legibly marked on the various sections plastered so that curing for the specified period thereafter can be watched.

#### **13.1.7 Finish**

The plaster shall be finished to a true and plumb surface and to the proper degree of smoothness as required. The work shall be tested frequently as the work proceeds with a true straight edge not less than 2.5 m long and with plumb bobs. All horizontal lines and surfaces shall be tested with a level and all jambs and corners with a plumb bob as the work proceeds.

#### **13.1.8 Precaution**

Any cracks which appear in the surface and all portions which sound hollow when tapped, or are found to be soft or otherwise defective, shall be cut out in rectangular shape and redone as directed by the Engineer-in-Charge.

(i) When ceiling plaster is done, it shall be finished to chamfered edge at an angle at its junction with a suitable tool when plaster is being done. Similarly when the wall plaster is being done, it shall be kept separate from the ceiling plaster by a thin straight groove not deeper than 6 mm drawn with any suitable method with the wall while the plaster is green.

(ii) To prevent surface cracks appearing between junctions of column/beam and walls, 150 mm wide chicken wire mesh should be fixed with U nails 150 mm centre to centre before plastering the junction. The plastering of walls and beam/column in one vertical plane should be carried out in one go. For providing and fixing chicken wire mesh with U nails payment shall be made separately.

#### **13.1.9 Measurements**

**13.1.9.1** Length and breadth shall be measured correct to a cm and its area shall be calculated in square metres correct to two places of decimal.

**13.1.9.2** Thickness of the plaster shall be exclusive of the thickness of the key i.e. grooves, or open joints in brick work.

**13.1.9.3** The measurement of wall plaster shall be taken between the walls or partitions (the dimensions before the plaster shall be taken) for the length and from the top of the floor or skirting to the ceiling for the height. Depth of coves or cornices if any shall be deducted.

**13.1.9.4** The following shall be measured separately from wall plaster.

- (a) Plaster bands 30 cm wide and under
- (b) Cornice beadings and architraves or architraves moulded wholly in plaster.
- (c) Circular work not exceeding 6 m in radius.

**13.1.9.5** Plaster over masonry pilasters will be measured and paid for as plaster only.

**13.1.9.6** A coefficient of 1.63 shall be adopted for the measurement of one side plastering on honey comb work having 6 x 10 cm. opening.

### **13.1.9.7 Moulded cornices and coves.**

- (a) Length shall be measured at the centre of the girth.
- (b) Moulded cornices and coves shall be given in square metres the area being arrived at by multiplying length by the girth.
- (c) Flat or weathered top to cornices when exceeding 15 cm in width shall not be included in the girth but measured with the general plaster work.
- (d) Cornices which are curved in their length shall be measured separately.

**13.1.9.8** Exterior plastering at a height greater than 10 m from average ground level shall be measured separately in each storey height. Patch plastering (in repairs) shall be measured as plastering new work, where the patch exceed 2.5 sqm. extra payment being made for preparing old wall, such as dismantling old plaster, raking out the joints and cleaning the surface. Where the patch does not exceed 2.5 sqm in area it shall be measured under the appropriate item under sub head 'Repairs to Buildings.'

**13.1.9.9** Deductions in measurements, for opening etc. will be regulated as follows:

- (a) No deduction will be made for openings or ends of joists, beams, posts, girders, steps etc. upto 0.5 sqm in area and no additions shall be made either, for the jambs, soffits and sills of such openings. The above procedure will apply to both faces of wall.
- (b) Deduction for opening exceeding 0.5 sqm but not exceeding 3 sqm each shall be made for reveals, jambs, soffits sills, sills, etc. of these openings.
  - (i) When both faces of walls are plastered with same plaster, deductions shall be made for one face only.
  - (ii) When two faces of walls are plastered with different types of plaster or if one face is plastered and other is pointed or one face is plastered and other is unplastered, deduction shall be made from the plaster or pointing on the side of the frame for the doors, windows etc. on which width of reveals is less than that on the other side but no deduction shall be made on the other side. Where width of reveals on both faces of wall are equal, deduction of 50% of area of opening on each face shall be made from area of plaster and/or pointing as the case may be. (iii) For opening having door frame equal to or projecting beyond thickness of wall, full deduction for opening shall be made from each plastered face of wall.
- (c) For opening exceeding 3 sqm in area, deduction will be made in the measurements for the full opening of the wall treatment on both faces, while at the same time, jambs, sills and soffits will be measured for payment. In measuring jambs, sills and soffits, deduction shall not be made for the area in contact with the frame of doors, windows etc.

### **13.1.10 Rate**

The rate shall include the cost of all labour and materials involved in all the operations described above.

## **13.2 CEMENT PLASTER WITH A FLOATING COAT OF NEAT CEMENT**

**13.2.0** The cement plaster shall be 12, 15 or 20 mm thick, finished with a floating coat of neat cement, as described in the item.

**13.2.1** Specifications for this item of work shall be same as described in 13.1 except for the additional floating coat which shall be carried out as below.

When the plaster has been brought to a true surface with the wooden straight edge (clause 13.1.4.2) it shall be uniformly treated over its entire area with a paste of neat cement and rubbed smooth, so that the whole surface is covered with neat cement coating. The quantity of cement applied for floating coat shall be 1 kg per sqm. Smooth finishing shall be completed with trowel immediately and in no case later than half an hour of adding water to the plaster mix. The rest of the specifications described in 13.1.4 shall apply.

### **13.3 18 MM CEMENT PLASTER (TWO COAT WORK)**

**13.3.1** The specification for scaffolding and preparation of surface shall be as described in 13.1

#### **13.3.2 Mortar**

The mix and type of fine aggregate specified in the description of the item shall be used for the respective coats. Generally the mix of the finishing coat shall not be richer than the under coat unless otherwise described in item.

Generally coarse sand shall be used for the under coat and fine sand for the finishing coat, unless otherwise specified for external work and under coat work, the fine aggregate shall conform to grading zone IV. For finishing coat work the fine aggregate conforming to grading zone V shall be used.

### **13.3.3 Application**

**13.3.3.1** The plaster shall be applied in two coats i.e. 12 mm under coat and then 6 mm finishing coat and shall have an average total thickness of not less than 18 mm.

**13.3.3.2 12 mm Under Coat :** This shall be applied as specified in 13.1.4 except that when the plaster has been brought to a true surface a wooden straight edge and the surface shall be left rough and furrowed 2 mm deep with a scratching tool diagonally both ways, to form key for the finishing coat. The surface shall be kept wet till the finishing coat is applied.

**13.3.3.3 6 mm Finishing Coat :** The finishing coat shall be applied after the under coat has sufficiently set but not dried and in any case within 48 hours and finished in the manner specified in 13.1.4.

**13.3.4** Specifications for Curing, Finishing, Precautions, Measurements and Rate shall be as described under 13.1.

## **13.4 6 MM CEMENT PLASTER ON CEMENT CONCRETE AND REINFORCED CEMENT**

### **CONCRETE WORK**

#### **13.4.1 Scaffolding**

Stage scaffolding shall be provided for the work. This shall be independent of the walls.

#### **13.4.2 Preparation of Surface**

Projecting burrs of mortar formed due to the gaps at joints in shuttering shall be removed. The surface shall be scrubbed clean with wire brushes. In addition concrete surfaces to be plastered shall be pock marked with a pointed tool, at spacings of not more than 5 cm. Centres, the pock being made not less than 3 mm deep. This is to ensure a proper key for the plaster. The mortar shall be washed off and surface, cleaned off all oil, grease etc. and well wetted before the plaster is applied.

#### **13.4.3 Mortars**

Mortar of the specified mix using the types of sand described in the item shall be used. It shall be as specified in 3.2.

#### **13.4.4 Application**

To ensure even thickness and a true surface, gauges of plaster 15 x 15 cm. shall be first applied at not more than 1.5 m intervals in both directions to serve as guides for the plastering. Surface of these gauged areas shall be truly in the plane of the finished plaster surface. The plaster shall be then applied in a uniform surface to a thickness slightly more than the specified thickness and shall then be brought to true and even surface by working a wooden straight edge reaching across the gauges. Finally the surface shall be finished true with a trowel or with wooden float to give a smooth or sandy granular texture as required. Excess troweling or over working of the floats shall be avoided. The plastering and finishing shall be completed within half an hour of adding water to the dry mortar. Plastering of ceiling shall not be commenced until the slab above has been finished and centring has been removed. In the case of ceiling of roof slabs, plaster shall not be commenced until the terrace work has been completed. These precautions are necessary in order that the ceiling plaster is not disturbed by the vibrations set up in the above operations.

#### **13.4.5 Finish**

The plaster shall be finished to a true and plumb surface and to the proper degree of smoothness as required. The work shall be tested frequently as the work proceeds with a true straight edge not less than 2.5 m long and with plumb bobs. All horizontal lines and surfaces shall be tested with a level and all jambs and corners with a plumb bob as the work proceeds.

#### **13.4.6 Thickness**

The average thickness of plaster shall not be less than 6 mm. The minimum thickness over any portion of the surface shall not be less than 5 mm.



### **13.4.7 Curing**

The specifications shall be as detailed in 13.1.6.

### **13.4.8 Precautions**

The specifications shall be as detailed in 13.1.8.

### **13.4.9 Measurements**

**13.4.9.1** Length and breadth shall be measured correct a cm. and its area shall be calculated in sqm. correct to two places of decimal. Dimensions before plastering shall be taken.

**13.4.9.2** Thickness of plaster shall be exclusive of the thickness of the key i.e. depth or rock marks and hacking.

**13.4.9.3** Plastering on ceiling at height greater than 5 m above the corresponding floor level shall be so described and shall be measured separately stating the height in stages of 1 m or part thereof.

**13.4.9.4** Plastering on the sides and soffits of the projected beams of ceiling at a height greater than 5 m above the corresponding floor level shall be measured and added to the quantity measured under 13.4.9.3.

**13.4.9.5** Plastering on spherical and groined ceiling and circular work not exceeding 6 m in radius, shall be measured and paid for separately.

**13.4.9.6** Flowing soffits (*viz.* portion under spiral stair case etc.) shall be measured and paid for separately.

**13.4.9.7** Ribs and mouldings on ceiling shall be measured as for cornices, deductions being made from the plastering on ceiling in case the width of the moulding exceed 15 cm.

**13.4.9.8** The mode of measurement of exterior plastering and patch plastering (in repairs) shall be as laid down in 13.1.9.8

**13.4.9.9** Deduction shall not be made for openings or for ends of columns, or columns caps of 0.5 sqm each in area and under. No additions will be made either for the plastering of the sides of such openings. For openings etc. of areas exceeding 0.5 sqm deduction will be made for the full opening but the sides of such openings shall be measured for payment.

### **13.4.10 Rate**

The rate shall include the cost of all labour and materials involved in all the operations described above.

## **13.6 NEAT CEMENT PUNNING**

**13.6.1** The specifications given for floating coat described in 13.2.1 shall apply.

**13.6.2** Specification for scaffolding and curing shall be as described in 13.1.1 and 13.1.6. respectively. Specifications for Finish and Precautions shall be as described in 13.1.7. and 13.1.8.

### **13.6.3 Measurements**

**13.6.3.1** The measurements for cement punning shall be taken over the finished work. The length and breadth shall be measured correct to a cm. The area shall be calculated in sqm correct to two places of decimal.

**13.6.3.2** Punning over Plaster on bands, skirting, coping, cornices, drip courses, string courses etc. shall not be measured separately but only as wall surfaces. In these cases the measurements shall be taken girthed over the above features.

**13.6.3.3** Punning over plaster on circular work also, of any radius shall be measured only as wall surfaces, and not separately.

**13.6.3.4** Cement punning in patch repairs irrespective of the size of the patch shall be measured as new work, and in this case the rate shall include for cutting the patch to rectangular shape before lime punning.

**13.6.3.5** Deductions in measurements for openings shall be regulated generally as described in 13.1.9.9.

### **13.6.4 Rate**

The rate shall include the cost of all labour and materials involved in all the operations described above.

## **13.12 CEMENT WATER PROOFING COMPOUND**

**13.12.0** It shall be used for cement mortar for plastering or concrete work.

### **13.12.1 Water Proofing Compound**

Integral cement water proofing compound conforming to IS 2645 and of approved brand and manufacture, enlisted by the Engineer-in-Charge from time to time shall be used.

**13.12.2** The contractor shall bring the materials to the site in their original packing. The containers will be opened and the material mixed with dry cement in the proportion by weight, recommended by the manufacturers or as specifically described in the description of the item. Care shall be taken in mixing, to see that the water proofing material gets well and integrally mixed with the cement and does not run out separately when water is added.

**13.12.3** It shall be measured by weight.

**13.12.4** The rate shall include the cost of all labour and materials involved in all the operations described above.

## **13.13 POINTING ON BRICK WORK, TILE WORK AND STONE WORK**

### **13.13.1 Scaffolding**

For all exposed brick work, tile work or stone work independent double scaffolding having two sets of vertical supports shall be provided. The supports shall be sound and strong tied together with horizontal pieces over which scaffolding planks shall be fixed. For all other work in building, single scaffolding shall be permitted. In such cases, the inner end of the horizontal scaffolding pole shall rest in a hole provided only in the header course for the purpose. Only one header for each pole shall be left out. Such holes for scaffolding shall, however, not be allowed in pillars/columns less than one metre in width, or immediately near the skew backs of arches. The holes

left in masonry works for scaffolding purposes shall be filled and made good before plastering.

**Note :** In case of special type of work, scaffolding shall be got approved from Engineer-in-Charge in advance.

### **13.13.2 Preparation of surface**

The joints shall be raked out properly. Dust and loose mortar shall be brushed out. Efflorescence if any shall be removed by brushing and scraping. The surface shall then be thoroughly washed with water, cleaned and kept wet before pointing is commenced. In case of concrete surface if a chemical retarder has been applied to the form work, the surface shall be roughened by wire brushing and all the resulting dust and loose particles cleaned off and care shall be taken that none of the retarders is left on the surface. The joints shall be raked to such a depth that the minimum depth of the new mortar measured from either the sunk surface of the finished pointing or from the edge of the brick shall not be less than 12 mm.

### **13.13.3 Mortar**

Mortar of specified mix shall be used. It shall be as specified under Chapter 3.0.

### **13.13.4 Application and Finishing**

**13.13.4.1** The mortar shall be pressed into the raked out joints, with a pointing trowel, either flush, sunk or raised, according to the type of pointing required. The mortar shall not spread over the corner, edges or surface of the masonry. The pointing shall then be finished with the proper tool, in the manner described below:

**13.13.4.2 *Flush Pointing* :** The mortar shall be pressed into the joints and shall be finished off flush and level with the edges of the bricks, tiles or stones so as to give a smooth appearance. The edges shall be neatly trimmed with a trowel and straight edge.

**13.13.4.3 *Ruled Pointing* :** The joints shall be initially formed as for flush pointing and then while the mortar is still green, a groove of shape and size as shown in drawings or as instructed, shall be formed by running a forming tool, straight along the centre line of the joints. This operation shall be continued till a smooth and hard surface is obtained. The vertical joints shall also be finished in a similar way. The vertical lines shall make true right angles at their junctions with the horizontal lines and shall not project beyond the same.

**13.13.4.4 *Cut or Weather Struck Pointing* :** The mortar shall first be pressed into the joints. The top of the horizontal joints shall then be neatly pressed back about 3 mm or as directed, with the pointing tool so that the joints are sloping from top to bottom. The vertical joints

shall be ruled pointed. The junctions of vertical joints with the horizontal joints shall be at true right angles.

**13.13.4.5 Raised and Cut Pointing :** Raised and cut pointing shall project from the wall facing with its edges cut parallel so as to have a uniformly raised band about 6 mm raised and width 10 mm more as directed.

**13.13.4.6** The superfluous mortar shall then be cut off from the edges of the lines and the surface of the masonry shall also be cleaned off all mortar. The finish shall be such that the pointing is to the exact size and shape required and the edges are straight, neat and clean.

**13.13.5 Curing**

The pointing shall be kept wet for seven days. During this period it shall be suitably protected from all damages. The pointing lines shall be truly horizontal and vertical except where the joints are slanting as in rubble random masonry. Lines of joints from different directions should meet neatly at the junctions instead of crossing beyond.

**13.13.6 Measurements**

**13.13.6.1** Length and breadth shall be measured correct to a cm and its area shall be calculated in square metres upto two places of decimal.

**13.13.6.2** The various types of pointing for example, struck, keyed, flush, tuck, etc. shall each be measured separately.

**13.13.6.3** Pointing on different types of walls, floors, roofs etc. shall each be measured separately. The type and material of the surface to be pointed shall be described.

**13.13.6.4** Pointing in a single detached joint as for flashing shall be given in running metres.

**13.13.6.5** For jambs, soffits, sills etc. for opening not exceeding 0.5 sqm each in area, ends of joists, beams, posts, girders, steps etc. not exceeding 0.5 sqm each in area and opening not exceeding 3 sqm each deductions and additions shall be made in the following way, in case of pointing on external face only.

(a) No deduction shall be made for ends of joists, beams, posts etc. and openings not exceeding 0.5 sqm each, and no addition shall be made for reveals, jambs, soffits, sills, etc. of these openings.

(b) Deductions for openings exceeding 0.5 sqm but not exceeding 3 sqm each shall be made as follows and no additions shall be made for reveals, jambs, soffits, sills, etc. for these openings.

(c) When both the faces of the wall are pointed with the same pointing deduction shall be made for one face only.

(d) When two faces of wall are pointed with different pointings or if one face is plastered and other is pointed or plastered, deduction shall be made from the plaster or pointing on the side of frames for doors, windows, etc. on which the width of the reveal is less than that on the other side, but no deduction shall be made from the other side.

(e) Where width of reveals on both faces of wall are equal, deduction of 50% of area of opening on each face shall be made from area of pointing or plaster as the case may be.

(f) For opening having door frame equal to or projecting beyond thickness of wall, full deduction for opening shall be made from each pointed face of wall.

**13.13.6.6** In case of openings of area above 3 sqm each, deduction shall be made for the openings, but jambs, soffits and sills shall be measured.

**13.13.6.7** The following shall be measured separately.

(a) Raking out joints for old work only shall be measured and given in square metres.

(b) Raking out joints of old work built in mud mortar, lime mortar and cement mortar shall each be measured separately.

(c) Raking out joints of different types of old walls, floors etc. shall each be measured separately.

(d) Raking single detached joints as for flashing old work shall be given in running metres.

**13.13.7 Rate**

The rate shall include the cost of all materials and labour involved in all the operations described above.

**13.19 OIL EMULSION (OIL BOUND) WASHABLE DISTEMPERING**

### **13.19.1 Materials**

Oil emulsion (Oil Bound) washable distemper (IS 428) of approved brand and manufacture shall be used. The primer where used as on new work shall be cement primer or distemper primer as described in the item. These shall be of the same manufacture as distemper. The distemper shall be diluted with water or any other prescribed thinner in a manner recommended by the manufacturer. Only sufficient quantity of distemper required for day's work shall be prepared. The distemper and primer shall be brought by the contractor in sealed tins in sufficient quantities at a time to suffice for a fortnight's work, and the same shall be kept in the joint custody of the contractor and the Engineer-in-Charge. The empty tins shall not be removed from the site of work, till this item of work has been completed and passed by the Engineer-in-Charge.

### **13.19.2 Preparation of the Surface**

**13.19.2.1** For new work the surface shall be thoroughly cleaned of dust, old white or colour wash by washing and scrubbing. The surface shall then be allowed to dry for at least 48 hours. It shall then be sand papered to give a smooth and even surface. Any unevenness shall be made good by applying putty, made of plaster of paris mixed with water on the entire surface including filling up the undulations and then sand papering the same after it is dry.

**13.19.2.2** In the case of old work, all loose pieces and scales shall be removed by sand papering. The surface shall be cleaned of all grease, dirt etc. Pitting in plaster shall be made good with plaster of paris mixed with the colour to be used. The surface shall then be rubbed down again with a fine grade sand paper and made smooth. A coat of the distemper shall be applied over the patches. The patched surface shall be allowed to dry thoroughly before the regular coat of distemper is applied.

### **13.19.3 Application**

**13.19.3.1 Priming Coat :** The priming coat shall be with distemper primer or cement primer, as required in the description of the item. The application of the distemper primer shall be as described in 13.18.4.

**Note :** If the wall surface plaster has not dried completely, cement primer shall be applied before distempering the walls. But if distempering is done after the wall surface is dried completely, distemper primer shall be applied. Oil bound distemper is not recommended to be applied, within six months of the completion of wall plaster. However, newly plastered surfaces if required to be distempered before a period of six months shall be given a coat of alkali resistant priming Paint conforming to IS 109 and allowed to dry for atleast 48 hours before distempering is commenced. For old work no primer coat is necessary.

**13.19.3.2 Distemper Coat :** For new work, after the primer coat has dried for at least 48 hours, the surface shall be lightly sand papered to make it smooth for receiving the distemper, taking care not to rub out the priming coat. All loose particles shall be dusted off after rubbing. One coat of distemper properly diluted with thinner (water or other liquid as stipulated by the manufacturer) shall be applied with brushes in horizontal strokes followed immediately by vertical ones which together constitutes one coat. The subsequent coats shall be applied in the same way. Two or more coats of distemper as are found necessary shall be applied over the primer coat to obtain an even shade. A time interval of at least 24 hours shall be allowed between successive coats to permit proper drying of the preceding coat. For old work the distemper shall be applied over the prepared surface in the same manner as in new work. One or more coats of distemper as are found necessary shall be applied to obtain an even and uniform shade. 15 cm double bristled distemper brushes shall be used. After each days work, brushes shall be thoroughly washed in hot water with soap solution and hung down to dry. Old brushes which are dirty and caked with distemper shall not be used on the work.

**13.19.4** The specifications in respect of scaffolding, protective measures and measurements shall be as described under 13.14.

### **13.19.5 Rate**

The rate shall include the cost of all labour and materials involved in all the above operations (including priming coat) described above.

### **13.20 CEMENT PRIMER COAT**

**13.20.0** Cement primer coat is used as a base coat on wall finish of cement, lime or lime cement plaster or on non-asbestos cement surfaces before oil emulsion distemper Paints are applied on them. The cement primer is composed of a medium and pigment which are resistant to the alkalies present in the cement, lime or lime cement in wall finish and provides a barrier for the protection of subsequent coats of oil emulsion distemper Paints. Primer coat shall be preferably applied by brushing and not by spraying. Hurried priming shall be avoided particularly on absorbent surfaces. New plaster patches in old work should also be treated with cement primer before applying oil emulsion Paints etc.

#### **13.20.1 Preparation of the Surface**

The surface shall be thoroughly cleaned of dust, old white or colour wash by washing and scrubbing. The surface shall then be allowed to dry for at least 48 hours. It shall then be sand papered to give a smooth and even surface. Any unevenness shall be made good by applying putty, made of plaster of paris mixed with water on the entire surface including filling up the undulations and then sand papering the same after it is dry.

#### **13.20.2 Application**

The cement primer shall be applied with a brush on the clean dry and smooth surface. Horizontal strokes shall be given first and vertical strokes shall be applied immediately afterwards. This entire operation will constitute one coat. The surface shall be finished as uniformly as possible leaving no brush marks. It shall be allowed to dry for at least 48 hours, before oil emulsion Paint is applied.

**13.20.3** The Specifications in respect of scaffolding, protective measures, measurements and rate shall be as described under 13.1.4.

### **13.21 CEMENT PAINT**

#### **13.21.1 Material**

The cement Paint shall be (conforming to IS 5410) of approved brand and manufacture. The cement Paint shall be brought to the site of work by the contractor in its original containers in sealed condition. The material shall be brought in at a time in adequate quantities to suffice for the whole work or at least a fortnight's work. The materials shall be kept in the joint custody of the Contractor and the Engineer-in-Charge. The empty containers shall not be removed from the site of work till the relevant item of the work has been completed and permission obtained from the Engineer-in-Charge.

#### **13.21.2 Preparation of Surface**

For New Work, the surface shall be thoroughly cleaned of all mortar dropping, dirt dust, algae, grease and other foreign matter by brushing and washing. Pitting in plaster shall be made good and a coat of water proof cement Paint shall be applied over patches after wetting them thoroughly.

#### **13.21.3 Preparation of Mix**

Cement Paint shall be mixed in such quantities as can be used up within an hour of its mixing as otherwise the mixture will set and thicken, affecting flow and finish. Cement Paint shall be mixed with water in two stages. The first stage shall comprise of 2 parts of cement Paint and one part of water stirred thoroughly and allowed to stand for 5 minutes. Care shall be taken to add the cement Paint gradually to the water and not *vice versa*. The second stage shall comprise of adding further one part of water to the mix and stirring thoroughly to obtain a liquid of workable and uniform consistency. In all cases the manufacturer's instructions shall be followed meticulously. The lids of cement Paint drums shall be kept tightly closed when not in use, as by exposure to atmosphere the cement Paint rapidly becomes air set due to its hygroscopic qualities. In case of cement Paint brought in gunny bags, once the bag is opened, the contents should be consumed in full on the day of its opening. If the same is not likely to be consumed in full, the balance quantity should be transferred and preserved in an airtight container to avoid its exposure to atmosphere.

#### **13.21.4 Application**

**13.21.4.1** The solution shall be applied on the clean and wetted surface with brushes or spraying machine. The solution shall be kept well stirred during the period of application. It shall be applied on the surface which is on the shady side of the building so that the direct heat of the sun on the surface is avoided. The method of application of cement Paint shall be as per manufacturer's specification. The completed surface shall be watered after the day's work.

**13.21.4.2** The second coat shall be applied after the first coat has been set for at least 24 hours. Before application of the second or subsequent coats, the surface of the previous coat shall not be wetted.

**13.21.4.3** For new work, the surface shall be treated with three or more coats of water proof cement Paint as found necessary to get a uniform shade.

**13.21.4.4** For old work, the treatment shall be with one or more coats as found necessary to get a uniform shade.

#### **13.21.5 Precaution**

Water proof cement Paint shall not be applied on surfaces already treated with white wash, colour wash, distemper dry or oil bound, varnishes, Paints etc. It shall not be applied on gypsums, wood and metal surfaces. If water proofing cement is required to be applied on existing surface, previously treated with white wash, colour wash etc., the surface shall be thoroughly cleaned by scrapping off all the white wash, colour wash etc. completely. Thereafter, a coat of cement primer shall be applied followed by two or more coat of water proof cement.

**13.21.6** The specifications in respect of scaffolding, protective measures, measurements and rate shall be as described under 13.14. The coefficient for cement Paint on RCC Jalli shall be the same as provided in Sl. No. 7 of Table 1 under para 13.23.6.4 for painting trellis for Jaffri work.

### **13.22 EXTERIOR PAINTING ON WALL**

#### **13.22.1 Material**

The paint shall be (Textured exterior paint/Acrylic smooth exterior paint/premium acrylic smooth exterior paint) of approved brand and manufacture. This paint shall be brought to the site of work by the contractor in its original containers in sealed condition. The material shall be brought in at a time in adequate quantities to suffice for the whole work or at least a fortnight's work. The materials shall be kept in the joint custody of the contractor and the Engineer-in-Charge. The empty containers shall not be removed from the site of work till the relevant item of work has been completed and permission obtained from the Engineer-in-Charge.

#### **13.22.2 Preparation of Surface**

For new work, the surface shall be thoroughly cleaned off all mortar dropping, dirt dust, algae, fungus or moth, grease and other foreign matter of brushing and washing, pitting in plaster shall make good, surface imperfections such as cracks, holes etc. should be repaired using white cement. The prepared surface shall have received the approval of the Engineer in charge after inspection before painting is commenced.

#### **13.22.3 Application**

Base coat of water proofing cement paint

**13.22.3.1** All specifications in respect of base coat of water proofing cement paint shall be as described under 13.21.

**13.22.3.2** Before pouring into smaller containers for use, the paint shall be stirred thoroughly in its container, when applying also the paint shall be continuously stirred in the smaller containers so that its consistency is kept uniform. Dilution ratio of paint with potable water can be altered taking into consideration the nature of surface climate and as per recommended dilution given by manufacturer. In all cases, the manufacturer's instructions & directions of the Engineer-in-charge shall be followed meticulously. The lids of paint drums shall be kept tightly closed when not in use as by exposure to atmosphere the paint may thicken and also be kept safe from dust. **13.22.3.3** Paint shall be applied with a brush on the cleaned and smooth surface. Horizontal strokes shall be given, First and

vertical strokes shall be applied immediately afterwards. This entire operation will constitute one coat. The surface shall be finished as uniformly as possible leaving no brush marks.

**13.22.4** The specifications in respect of scaffolding, protective measures, measurements and rate shall be as described under 13.14.

### **13.23 PAINTING**

#### **13.23.1 Materials**

Paints, oils, varnishes etc. of approved brand and manufacture shall be used. Only ready mixed Paint (Exterior grade) as received from the manufacturer without any admixture shall be used. If for any reason, thinning is necessary in case of ready mixed Paint, the brand of thinner recommended by the manufacturer or as instructed by the Engineer-in-Charge shall be used. Approved Paints, oil or varnishes shall be brought to the site of work by the contractor in their original containers in sealed condition. The material shall be brought in at a time in adequate quantities to suffice for the whole work or at least a fortnight's work. The materials shall be kept in the joint custody of the contractor and the Engineer-in-Charge. The empties shall not be removed from the site of work, till the relevant item of work has been completed and permission obtained from the Engineer-in-Charge.

#### **13.23.2 Commencing Work**

Painting shall not be started until the Engineer-in-Charge has inspected the items of work to be painted, satisfied himself about their proper quality and given his approval to commence the painting work. Painting of external surface should not be done in adverse weather condition like hail storm and dust storm. Painting, except the priming coat, shall generally be taken in hand after practically finishing all other building work. The rooms should be thoroughly swept out and the entire building cleaned up, at least one day in advance of the Paint work being started.

#### **13.23.3 Preparation of Surface**

The surface shall be thoroughly cleaned and dusted off. All rust, dirt, scales, smoke splashes, mortar droppings and grease shall be thoroughly removed before painting is started. The prepared surface shall have received the approval of the Engineer-in-Charge after inspection, before painting is commenced.

#### **13.23.4 Application**

**13.23.4.1** Before pouring into smaller containers for use, the Paint shall be stirred thoroughly in its containers, when applying also, the Paint shall be continuously stirred in the smaller containers so that its consistency is kept uniform.

**13.23.4.2** The painting shall be laid on evenly and smoothly by means of crossing and laying off, the latter in the direction of the grains of wood. The crossing and laying off consists of covering the area over with Paint, brushing the surface hard for the first time over and then brushing alternately in opposite direction, two or three times and then finally brushing lightly in a direction at right angles to the same. In this process, no brush marks shall be left after the laying off is finished. The full process of crossing and laying off will constitute one coat.

**13.23.4.3** Where so stipulated, the painting shall be done by spraying. Spray machine used may be (a) high pressure (small air aperture) type, or (b) a low pressure (large air gap) type, depending on the nature and location of work to be carried out. Skilled and experienced workmen shall be employed for this class of work. Paints used shall be brought to the requisite consistency by adding a suitable thinner.

**13.23.4.4** Spraying should be done only when dry condition prevails. Each coat shall be allowed to dry out thoroughly and rubbed smooth before the next coat is applied. This should be facilitated by thorough ventilation. Each coat except the last coat, shall be lightly rubbed down with sand paper or fine pumice stone and cleaned off dust before the next coat is laid.

**13.23.4.5** No left over Paint shall be put back into the stock tins. When not in use, the containers shall be kept properly closed.

**13.23.4.6** No hair marks from the brush or clogging of Paint puddles in the corners of panels, angles of mouldings etc. shall be left on the work.

**13.23.4.7** In painting doors and windows, the putty round the glass panes must also be painted but care must be taken to see that no Paint stains etc. are left on the glass. Tops of shutters and surfaces in similar hidden locations shall not be left out in painting. However, bottom edge of the shutters where the painting is not practically possible, need not be done nor any deduction on this account will be done but two coats of primer of approved make shall be done on the bottom edge before fixing the shutters.

**13.23.4.8** On painting steel work, special care shall be taken while painting over bolts, nuts, rivets overlaps etc.

**13.23.4.9** The additional specifications for primer and other coats of Paints shall be as according to the detailed specifications under the respective headings.

### **13.23.5 Brushes and Containers**

After work, the brushes shall be completely cleaned of Paint and linseed oil by rinsing with turpentine. A brush in which Paint has dried up is ruined and shall on no account be used for painting work. The containers when not in use, shall be kept closed and free from air so that Paint does not thicken and also shall be kept safe from dust. When the Paint has been used, the containers shall be washed with turpentine and wiped dry with soft clean cloth, so that they are clean, and can be used again.

### **13.23.6 Measurements**

**13.23.6.1** The length and breadth shall be measured correct to a cm. The area shall be calculated in sqm (correct to two places of decimal), except otherwise stated.

**13.23.6.2** Small articles not exceeding 10 sq. decimetre (0.1 sqm) of painted surfaces where not in conjunction with similar painted work shall be enumerated.

**13.23.6.3** Painting upto 10 cm in width or in girth and not in conjunction with similar painted work shall be given in running metres and shall include cutting to line where so required.

**Note :** Components of trusses, compound girders, stanchions, lattices and similar work shall, however, be given in sq. metres irrespective of the size or girth of members. Priming coat of painting shall be included in the work of fabrication.

**13.23.6.4** In measuring painting, varnishing, oiling etc. of joinery and steel work etc. The coefficients as indicated in following tables shall be used to obtain the area payable. The coefficients shall be applied to the areas measured flat and not girthed.

**TABLE 13.1**  
**Equivalent Plain Areas of Uneven Surface**

S. No.	Description of work	How measured	Multiplying coefficients
1	2	3	4
<b>I. Wood work doors, windows Etc.</b>			
1.	Panelled or framed and braced doors, windows etc.	Measured flat (not girthed including)	1.30 (for each side)
2.	Ledged and battened or ledged, battened and braced doors, windows etc.	Chowkhat or frame, Edges, chocks, cleats, etc. shall be deemed to be included in the item.	- do -
3.	Flush doors etc.	-do-	1.20 (for each side)
4.	Part panelled and part glazed or gauzed doors, window etc. (Excluding painting of wire gauze portion)	-do-	1.00 (for each side)
5.	Fully glazed or gauzed doors, windows etc. (Excluding painting of wire gauze portion)	-do-	0.80 (for each side)
6.	Fully venetioned or louvered doors, windows etc.	-do-	1.80 (for each side)
7.	Trellis (or Jaffri) work one way or two way	Measured flat overall, no deduction shall be made for open spaces, supporting members shall not be measured separately	2 (for painting all over)
8.	Carved or enriched work	Measured flat	2 (for each side)
9.	Weather boarding	Measured flat (not girthed supporting frame work shall not be measured separately)	1.20 (for each side)
10.	Wood shingle roofing	Measured flat (not girthed)	1.10 (for each side)



1	2	3	4
11.	Boarding with cover fillets and match boarding	Measured flat (not girthed)	1.05 (for each side)
12.	Tile and slate battening	Measured flat overall no deductions shall be made for open spaces	0.80 (for painting all over)
<b>II. Steel work doors, windows Etc.</b>			
13.	Plain sheeted steel doors or windows	Measured flat (not girthed) including frame edges etc.	1.10 (for each side)
14.	Fully glazed or gauzed steel doors and windows (excluding painting of wire gauze portion)	-do-	0.50 (for each side)
15.	Partly panelled and partly glazed or gauzed doors and windows (excluding painting of wire gauze portion)	-do-	0.80 (for each side)
16.	Corrugated sheeted steel doors or windows	-do-	1.25 (for each side)
17.	Collapsible gates	Measured flat	1.50 (for painting all over)
18.	Rolling shutters of interlocked laths	Measured flat (size of opening) all over; jamb guides, bottom rails and locking arrangement etc. shall be included in the item (top cover shall be measured separately)	1.10 (for each side)
<b>III. General</b>			
19.	Expanded metal, hard drawn steel wire fabric of approved quality, grill works and gratings in guard bars, balustrades, railing partitions and MS Bars in windows frames.	Measured flat overall; no deduction shall be made for open spaces; supporting members shall not be measured separately	1 (for Paint all over)
20.	Open palisade fencing and gates including standards, braces, rails stays etc. in timber or steel	-do- (see note No. 12)	1 (for Paint all over)
21.	Corrugated iron sheeting in roofs, side cladding etc.	-do- Measured flat (not girthed)	1.14 (for each side)
22.	AC corrugated sheeting in roofs, side cladding etc.	-do-	1.20 (for each side)
23.	AC semi corrugated sheeting in roofs, side cladding etc. or Nainital pattern using plain sheets	-do-	1.10 (for each side)
24.	Wire gauze shutters including painting of wire gauze	-do-	1.00 (for each side)

### Explanatory Notes for Table 13.1

(1) Measurements for doors windows etc., shall be taken flat (and not girthed) over all including chowkhuts or frames, where provided. Where Chowkhuts or frames are not provided, the shutter measurements shall be taken.

(2) Where doors, windows etc., are of composite types other than those included in Table 1 the different portion shall be measured separately with their appropriate coefficients, the centre line of the common rail being taken as the dividing line between the two portions.

(3) The coefficients for door and windows shall apply irrespective of the size of frames and shutter members.

(4) In case steel frames are used the area of doors, windows shutters shall be measured flat excluding frames.

(5) When the two faces of a door, window etc. are to be treated with different specified finishes, measurable under separate items, the edges of frames and shutters shall be treated with the one or the other type of finish as ordered by the Engineer-in-Charge and measurement of this will be deemed to be included in the measurement of the face treated with that finish.

(6) In the case where shutters are fixed on both faces of the frames, the measurement for the door frame and shutter on one face shall be taken in the manner already described, while the

additional shutter on the other face will be measured for the shutter only excluding the frame.

(7) Where shutters are provided with clearance at top or/and bottom each exceeding 15 cm height, such openings shall be deducted from the overall measurements and relevant coefficient shall be applied to obtain the area payable.

(8) Collapsible gates shall be measured for width from outside to outside of gate in its expanded position and for height from bottom to top of channel verticals. No separate measurements shall be taken for the top and bottom guide rails rollers, fittings etc.

(9) Coefficients for sliding doors shall be the same as for normal types of doors in the table. Measurements shall be taken outside to outside of shutters, and no separate measurements shall be taken for the painting guide rails, rollers, fittings etc.

(10) Measurements of painting as above shall be deemed to include painting all iron fittings in the same or different shade for which no extra will be paid.

(11) The measurements of guard bars, expanded metal, hard drawn steel wire fabric of approved quality, grill work and gratings, when fixed in frame work, painting of which is once measured else where shall be taken exclusive of the frames. In other cases the measurements shall be taken inclusive of the frames.

(12) For painting open palisade fencing and gates etc., the height shall be measured from the bottom of the lowest rail, if the palisades do not go below it, (or from the lower end of the palisades, if they project below the lowest rail), upto the top of rails or palisades whichever are higher, but not up to the top of standards when the latter are higher than the top rails or the palisades.

**13.23.6.5** Width of moulded work of all other kinds, as in hand rails, cornices, architraves shall be measured by girth.

**13.23.6.6** For trusses, compound girders, stanchions, lattice girders, and similar work, actual areas will be measured in sq. metre and no extra shall be paid for painting on bolt heads, nuts, washers etc. even when they are picked out in a different tint to the adjacent work.

**13.23.6.7** Painting of rain water, soil, waste, vent and water pipes etc. shall be measured in running metres of the particular diameter of the pipe concerned. Painting of specials such as bends, heads, branches, junctions, shoes, etc. shall be included in the length and no separate measurements shall be taken for these or for painting brackets, clamps etc.

**13.23.6.8** Measurements of wall surfaces and wood and other work not referred to already shall be recorded as per actual.

**13.23.6.9** Flag staffs, steel chimneys, aerial masts, spires and other such objects requiring special scaffolding shall be measured separately.

### **13.23.7 Precautions**

All furnitures, fixtures, glazing, floors etc. shall be protected by covering and stains, smears, splashings, if any shall be removed and any damages done shall be made good by the contractor at his cost.

### **13.23.8 Rate**

Rates shall include cost of all labour and materials involved in all the operations described above and in the particular specifications given under the several items.

## **13.24 PAINTING PRIMING COAT ON WOOD, IRON OR PLASTERED SURFACES**

### **13.24.1 Primer**

**13.24.1.1** The primer for wood work, iron work or plastered surface shall be as specified in the description of item.

**13.24.1.2** Primer for plaster/wood work/Iron & Steel/Aluminium surfaces shall be as specified below:

**TABLE 13.2**

S.No.	Surfaces	Primer to be used
1.	Wood work (hard and soft wood)	Pink conforming to IS 3536
2.	Resinour wood and plywood	Aluminium primer conforming to IS 3585
3.	(A) Aluminium and light alloys	Zinc chromate primer conforming to IS 104
	(B) Iron, Steel and Galvanized steel	Red Oxide Zinc chromate Primer conforming IS 2074
4.	Cement/Conc/RCC/brick work, Plastered surfaces, non-asbestos surfaces to receive Oil bound distemper or Paint finish.	Cement primer conforming to IS 109

**13.24.1.3** The primer shall be ready mixed primer of approved brand and manufacture.

**13.24.1.4** Where primer for wood work is specified to be mixed at site, it shall be prepared from a mixture of red lead, white lead and double boiled linseed oil in the ratio of 0.7 kg : 0.7 kg : 1 litre.

**13.24.1.5** Where primer for steel work is specified to be mixed at site, it shall be prepared from a mixture of red lead, raw linseed oil and turpentine in the ratio of 2.8 kg : 1 litre : 1 litre.

**13.24.1.6** The specifications for the base vehicle and thinner for mixed on site primer shall be as follows:

(a) *White Lead* : The White lead shall be pure and free from adulterants like barium sulphate and whiting. It shall conform to IS 103.

(b) *Red Lead* : This shall be in powder form and shall be pure and free from adulterants like brick dust etc. It shall conform to IS 102.

(c) *Raw Linseed Oil* : Raw linseed oil shall be lightly viscous but clear and of yellowish colour with light brown tinge. Its specific gravity at a temperature of 30 degree C shall be between 0.923 and 0.928.

**Note** : The oil shall be mellow and sweet to the taste with very little smell. The oil shall be of sufficiently matured quality. Oil turbid or thick, with acid and bitter taste and rancid odour and which remains sticky for a considerable time shall be rejected. The oil shall conform in all respects to IS 75. The oil shall be of approved brand and manufacture.

(d) *Double Boiled Linseed Oil* : This shall be more viscous than the raw oil, have a deeper colour and specific gravity between 0.931 and 0.945 at a temperature of 30 degree C. It shall dry with a glossy surface. It shall conform in all respects to IS 77. The oil shall be of approved brand and manufacture.

**Turpentine** : Mineral turpentine i.e. petroleum distillate which has the same rate of evaporation as vegetable turpentine (distillate product of oleoresin of conifers) shall be used. It shall have no grease or other residue when allowed to evaporate. It shall conform to IS 533.

**13.24.1.7** All the above materials shall be of approved manufacture and brought to site in their original packing in sealed condition.

**13.24.2 Preparation of Surface**

**13.24.2.1 Wooden Surface** : The wood work to be painted shall be dry and free from moisture. The surface shall be thoroughly cleaned. All unevenness shall be rubbed down smooth with sand paper and shall be well dusted. Knots, if any shall be covered with preparation of red lead made by grinding red lead in water and mixing with strong glue sized and used hot. Appropriate filler material conforming to IS 345 with same shade as Paint shall be used where specified. The surface treated for knotting shall be dry before Paint is applied. After obtaining approval of Engineer-in-Charge for wood work, the priming coat shall be applied before the wood work is fixed in position. After the priming coat is applied, the holes and indentation on the surface shall be stopped with glazier's putty

or wood putty. Stopping shall not be done before the priming coat is applied as the wood will absorb the oil in stopping and the latter is therefore liable to crack.

**13.24.2.2 Iron & Steel Surface :** All rust and scales shall be removed by scrapping or by brushing with steel wire brushes. Hard skin of oxide formed on the surface of wrought iron during rolling which becomes loose by rusting, shall be removed. All dust and dirt shall be thoroughly wiped away from the surface. If the surface is wet, it shall be dried before priming coat is undertaken.

**13.24.2.3 Plastered Surface :** The surface shall ordinarily not be painted until it has dried completely. Trial patches of primer shall be laid at intervals and where drying is satisfactory, painting shall then be taken in hand. Before primer is applied, holes and undulations, shall be filled up with plaster of paris and rubbed smooth.

#### **13.24.3 Application**

The primer shall be applied with brushes, worked well into the surface and spread even and smooth. The painting shall be done by crossing and laying off as described in 13.22.3.3.

#### **13.24.4 Treatment on Steel for Aggressive Environment**

**13.24.4.1** A second coat of ready mixed red oxide zinc chromate primer may be applied where considered necessary in aggressive environment such as near Industrial Establishment and Coastal regions where the steel members are prone to corrosion. The second coat (which shall be paid for separately) is to be applied after placing the member in position and just before applying Paint. The second coat of primer is not necessary in case of painting with synthetic enamel Paint as it is applied over an under coat of ordinary Paint.

**13.24.4.2** The specifications described under 13.33 shall hold good so far as they are applicable.

### **13.32 PAINTING WITH SYNTHETIC ENAMEL PAINT**

**13.32.1** Synthetic Enamel Paint (conforming to IS 2933) of approved brand and manufacture and of the required colour shall be used for the top coat and an undercoat of ordinary Paint of shade to match the top coat as recommended by the same manufacturer as far the top coat shall be used.

#### **13.32.2 Painting on New Surface**

**13.32.2.1** Preparation of surface shall be as specified in 13.24.2 as the case may be.

**13.32.2.2 Application :** The number of coats including the undercoat shall be as stipulated in the item.

(a) *Under Coat* : One coat of the specified ordinary Paint of shade suited to the shade of the top coat, shall be applied and allowed to dry overnight. It shall be rubbed next day with the finest grade of wet abrasive paper to ensure a smooth and even surface, free from brush marks and all loose particles dusted off.

(b) *Top Coat* : Top coats of synthetic enamel Paint of desired shade shall be applied after the undercoat is thoroughly dry. Additional finishing coats shall be applied if found necessary to ensure properly uniform glossy surface.

**13.32.2.3** Other details shall be as specified in 13.22 as far as they are applicable.

#### **13.32.3 Painting on Old Surface**

**13.32.3.1 Preparation of Surface :** Where the existing Paint is firm and sound it shall be cleaned of grease, smoke etc. and rubbed with sand paper to remove all loose particles dusted off. All patches and cracks shall then be treated with stopping and filler prepared with the specified Paint. The surface shall again be rubbed and made smooth and uniform. If the old paint is blistered and flaked it will be necessary to completely remove the same as described in para 13.41. Such removal shall be paid for separately and the painting shall be treated as on new surface.

**13.32.3.2 Painting :** The number of coats as stipulated in the item shall be applied with synthetic enamel Paint. Each coat shall be allowed to dry and rubbed down smooth with very fine wet abrasive paper, to get an even glossy surface. If however, the surface is not satisfactory additional coats as required shall be applied to get correct finish.

**13.32.3.3** Other details shall be specified in 13.22 as far as they are applicable.

### **13.35 PAINTING WITH ANTI-CORROSIVE BITUMASTIC PAINT**

**13.35.1** Ready mixed Paint (conforming to IS 158) shall be of approved brand and manufacture. It shall be black, lead free, acid-alkali-heat-water resistant.

**13.35.2** Preparation of surface and application shall be as specified in 13.32 for painting on new or old surfaces as the case may be. The drying time between consecutive coats, however, shall be not less than 3 hours.

**13.35.3** Other details shall be as specified in 13.23 as far as applicable.

**Note:- For further detail refer CPWD specification Volume 2, Sub Head 13.0**

**SUB HEAD : 14.0**  
**REPAIRS TO BUILDINGS**

**14.1 REPAIRS TO PLASTER**

**14.1.0** The work includes cutting the patch and preparing the wall surface. Patches of 2.50 square metres and less in area shall be measured under item of 'Repairs to Plaster' under this sub-head. Plastering in patches over 2.5 square metres in area shall be paid for at the rate as applicable to new work under sub head 'Finishing'.

**14.1.1 Scaffolding**

Scaffolding as required for the proper execution of the work shall be erected. If work can be done safely with the ladder or jhoola these will be permitted in place of scaffolding.

**14.1.2 Cutting**

The mortar of the patch, where the existing plaster has cracked, crumbled or sounds hollow when gently tapped on the surface, shall be removed. The patch shall be cut out to a square or rectangular shape at position marked on the wall as directed by the Engineer-in-Charge or his authorized representative. The edges shall be slightly under cut to provide a neat joint.

**14.1.3 Preparation of Surface**

The masonry joints which become exposed after removal of old plaster shall be raked out to a minimum depth of 10 mm in the case of brick work and 20 mm in the case of stone work. The raking shall be carried out uniformly with a raking tool and not with a basuli, and loose mortar dusted off. The surface shall then be thoroughly washed with water, and kept wet till plastering is commenced.

In case of concrete surfaces, the same shall be thoroughly scrubbed with wire brushes after the plaster had been cut out and pock marked as described in 13.1.2. The surface shall be washed and cleaned and kept wet till plastering is commenced.

**14.1.4 Application of Plaster**

Mortar of specified mix with the specified sand shall be used. The method of application shall be as described for single coat plaster work of the specified mix and under Chapter 13. The surface shall be finished even and flush and matching with the old surrounding plaster. All roundings necessary at junctions of walls, ceilings etc. shall be carried out in a tidy manner as specified in sub-head 13.0. All dismantled mortar & rubbish etc. shall be disposed off within 24 hours from its dismantling promptly as directed by the Engineer-in-Charge.

**14.1.5 Protective Measure**

Doors, windows, floors, articles of furniture etc. and such other parts of the building shall be protected from being splashed upon. Splashing and droppings, if any, shall be removed by the contractor at his own cost and the surface cleaned. Damages, if any, to furniture or fittings and fixtures shall be recoverable from the contractor.

**14.1.6 Curing**

Curing shall be done as per plaster work with special reference to the particular type of plaster mix as described under sub-head 'finishing'.

**14.1.7 Finishing**

After the plaster is thoroughly cured and dried the surface shall be white washed or colour washed to suit the existing finishing as required unless specified

**14.1.8 Measurements**

Length and breadth shall be measured correct to a cm. The area shall be calculated in square metre correct to two places of decimal. Patches below 0.05 square metre in area shall not be measured for payment. Pre-measurements of the patches to be plastered shall be recorded after the old plaster has been cut and wall surface prepared.

**14.1.9 Rate**

The rate includes the cost of all the materials and labour involved in all the operations described above including lead as described in the item for disposal of old dismantled plaster /material.

**Note:- For further detail refer CPWD specification volume 2, Sub Head 14.0.**

**SUB HEAD : 15.0**  
**DISMANTLING AND DEMOLISHING**

**15.0 TERMINOLOGY**

(i) **Dismantling:** The term 'Dismantling' implies carefully separating the parts without damage and removing. This may consist of dismantling one or more parts of the building as specified or shown on the drawings.

(ii) **Demolition :** The term 'Demolition' implies breaking up. This shall consist of demolishing whole or part of work including all relevant items as specified or shown on the drawings.

**15.1 GENERAL**

This chapter relates to buildings only.

**15.1.1 Precautions**

**15.1.1.1** All materials obtained from dismantling or demolition shall be the property of the Government unless otherwise specified and shall be kept in safe custody until they are handed over to the Engineer in-Charge/ authorized representative.

**15.1.1.2** The demolition shall always be well planned before hand and shall generally be done in reverse order of the one in which the structure was constructed. The operations shall be got approved from the Engineer-in-Charge before starting the work Due care shall be taken to maintain the safety measures prescribed in IS 4130.

**15.1.1.3** Necessary propping, shoring and or under pinning shall be provided to ensure the safety of the adjoining work or property before dismantling and demolishing is taken up and the work shall be carried out in such a way that no damage is caused to the adjoining work or property. Wherever specified, temporary enclosures or partitions and necessary scaffolding with suitable double scaffolding and proper cloth covering shall also be provided, as directed by the Engineer-in-Charge.

**15.1.1.4** Necessary precautions shall be taken to keep noise and dust nuisance to the minimum. All work needs to be done under the direction of Engineer-in-Charge. Helmets, goggles, safety belts etc. should be used whenever required and as directed by the Engineer-in-Charge. The demolition work shall be proceeded with in such a way that it causes the least damage and nuisance to the adjoining building and the public.

**15.1.1.5** Dismantling shall be done in a systematic manner. All materials which are likely to be damaged by dropping from a height or by demolishing roofs, masonry etc. shall be carefully removed first. Chisels and cutters may be used carefully as directed. The dismantled articles shall be removed manually or otherwise, lowered to the ground (and not thrown) and then properly stacked as directed by the Engineer-in-Charge.

**15.1.1.6** Where existing fixing is done by nails, screws, bolts, rivets, etc., dismantling shall be done by taking out the fixing with proper tools and not by tearing or ripping off.

**15.1.1.7** Any serviceable material, obtained during dismantling or demolition, shall be separated out and stacked properly as directed by the Engineer-in-Charge within a lead of 50 metres. All unserviceable materials, rubbish etc. shall be disposed off as directed by the Engineer-in-Charge .

**15.1.1.8** The contractor shall maintain/disconnect existing Service, whether temporary or permanent, where required by the Engineer-in-Charge.

**15.1.1.9** No demolition work should be carried out at night especially when the building or structure to be demolished is in an inhabited area.

**15.1.1.10** Screens shall be placed where necessary to prevent injuries due to falling pieces.

**15.1.1.11** Water may be used to reduce dust while tearing down plaster from brick work.

**15.1.1.12** Safety belts shall be used by laborers while working at higher level to prevent falling from the structure.

**15.1.1.13** First-aid equipment shall be got available at all demolition works of any magnitude.

**15.3.11 Reinforced Concrete and Brick Work**

Reinforced concrete structures and reinforced brick roofs and walls shall be measured in cubic metres and if reinforcement is required to be salvaged, it shall be so stated Where reinforcement is required to be separated, scraped and cleaned, the work shall be measured separately in quintal of salvaged steel.

**15.3.13 Wood Work**

All wood work including karris average 40 sq cm or over in section, shall be measured in cubic metres, while that under 40 sq cm in section, in running metres. Ballies shall be measured in running metres Boarding including wooden chajjas and sun shades along with supports shall be measured in square metres in its plane.

**15.3.15 Doors and Windows**

Dismantling of doors, windows, clerestory windows, ventilators etc. (wood or metal) whether done separately or along with removal of wall by making recess in the wall shall be enumerated. Those exceeding 3 sqm each in area shall be measured separately. The item shall include removal of chowkhats architraves, holdfasts and other attachments. If only shutters are to be taken out it shall be measured separately.

**Note:- For further detail refer CPWD specification volume 2, Sub Head 15.0**



**SUB HEAD : 16.0  
ROAD WORK**

**16.1.1 Aggregate Coarse**

Coarse aggregate as specified in the item shall be either crushed/broken stone, crushed slag, over burnt brick aggregate or one of the naturally occurring aggregates such as kanker or laterite of suitable quality as stated hereinafter and approved by the Engineer-in-Charge. The stone aggregate shall conform to the physical requirements set forth in Table 15.1. The type and size range of the aggregate shall be specified in the contract.

-----  
**Physical Requirements of Coarse Aggregate**

Sl. No.	Type of Constn.	Test for W.B.M.	Test method	Requirements
1.	Sub-base	Los Angles Abrasion value or Aggregate impact value	IS 2386 (Pt.IV) IS 2386 (Pt.IV) IS 5640***	60% max. *50% max.
2.	Base	(a) Los Angles Abrasion value or Aggregate impact value	IS 2386 (Pt.IV) IS 2386 (Pt.IV) IS 5640***	50% max. *40% max.
		(b) Flakiness Index	IS 2386 (Pt.I)	**15% max.
3.	Surface Course	(a) Los Angles Abrasion value or Aggregate impact value	IS 2386 (Pt.IV) IS 2386 (Pt.IV)	40% max. 30% max.
		(b) Flakiness Index	IS 2386 (Pt.I)	**15% max.
<p>* Aggregates may satisfy requirements of either of the two tests.  ** The requirements of flakiness index shall be enforced only in case of crushed/broken stone and crushed slag.  *** Aggregates like brick metal, kankar and laterite which get softened in presence of water, shall be tested for impact value under wet conditions in accordance with IS 5640.</p>				

**Grading Requirements of Coarse Aggregate for W.B.M.**

Grading No.	Size Range	Sieve Designation	% by weight passing the sieve
1.	90 mm to 45 mm (Suitable for sub base courses of compacted layer of not less than 90 mm thickness)	125 mm 90 mm 63 mm 45 mm 22.4 mm	100 90 - 100 25 - 60 0 - 15 0 - 5
2.	63 mm to 45 mm	90 mm 63 mm 53 mm 45 mm 22.4 mm	100 90 - 100 25 - 75 0 - 15 0 - 5
3.	53 mm to 22.4 mm	63 mm 53 mm 45 mm 22.4 mm 11.2 mm	100 95 - 100 65 - 90 0 - 10 0 - 5

**16.2 SUB-GRADE : PREPARATION AND CONSOLIDATION**

**16.2.0** In sub-grade composed of clay, fine sand or other soils that may be forced up into the coarse aggregate during rolling operation, an insulation layer of suitable thickness of granular materials or oversize brick aggregate not less than 10 cm thick shall be provided for blanketing the sub-grade, which shall be paid for separately, unless otherwise specified. In slushy soils or in areas that are water logged, special arrangements shall be made to improve the sub-grade and the total pavement thickness shall be designed after testing the properties of the subgrade soil. Necessary provision for the special treatment required shall be made in the project and paid for separately.

**16.2.1 Preparation of Sub-Grade**

The surface of the formation for a width of sub-base, which shall be 15 cm more on either side of base course, shall first be cut to a depth equal to the combined depth of sub-base and surface courses below the proposed finished level (due allowance being made for consolidation). It shall then be cleaned of all foreign substances. Any ruts or soft yielding patches that appear due to improper drainage conditions, traffic hauling or from any other cause, shall be corrected and the sub-grade dressed off parallel to the finished profile.

**16.2.2 Consolidation**

The sub-grade shall be consolidated with a power road roller of 8 to 12 tonnes. The roller shall run over the sub grade till the soil is evenly and densely consolidated and behaves as an elastic mass (the roller shall pass a minimum of 5 runs on the sub grade). All undulations in the surface that develop due to rolling shall be made good with material or quarry spoils as the cases may be and the sub-grade is rerolled.

**16.2.3 Surface Regularity**

The finished surface shall be uniform and conform to the lines, grades and typical cross section shown in the drawings, when tested with the template and straight edge, the variation shall be within the tolerances specified in

**16.36 CEMENT CONCRETE PAVEMENT (UNDER ORDINARY CONDITIONS)**

Specifications of item 16.37 to be followed except that cement concrete of grade 1:2:4 or specified otherwise to be prepared and compacted.

**16.37 CEMENT CONCRETE PAVEMENT UNDER CONTROLLED CONDITIONS**

**16.37.1 Materials**

**16.37.1.1 Cement**

(a) Cement used on work shall be as per sub head cement concrete of CPWD specifications-2009 (Vol. – I).

**16.37.1.2 Water :** Water used on work shall conform to SH: cement concrete of CPWD, Specification 2009- Vol. I.

**16.37.1.3 Coarse Aggregate :** These shall be crushed or broken from hard stones obtained from approved quarry. These shall be clean strong, durable of fairly cubical shape and free from soft, friable, thin elongated and laminated disintegrated pieces. These shall also be free from dirt, organic deleterious and any other foreign matter and adherent coatings and shall satisfy the physical requirements laid down in para 16.37.19 under quality control.

**16.37.1.4 Fine Aggregate :** This shall be coarse sand conforming to CPWD Specification 2009 Vol. I.

**16.37.1.5 Grading of Mixed Aggregates :** The grading of all aggregates (coarse and fine aggregates) to be used in the work shall be determined in the laboratory. The coarse and fine aggregates shall be mixed in suitable proportions so that the grading of the mixed aggregates shall be in the range indicated in Table 16.32.

**TABLE 16.32**

<i>I.S. Sieve Size (IS 460)</i>	<i>%age passing by weight</i>
45 mm	100
22.4 mm	55 - 60
11.2 mm	45 - 50
5.6 mm	35 - 40
2.8 mm	30 - 35
1.4 mm	20 - 25
710 microns	15 - 20
355 microns	10 - 14
180 microns	2 - 5

**16.37.2 Mix Design**

**16.37.2.1** The mix shall be approved by Engineer-in-Charge so as to obtain the following mean strength that exceeds the minimum specified flexural strength by 1.64 times the designed standard deviation.

Minimum works beam flexural strength at 28 days = 300 kg/sqm. for M-30 or specified in item

Designed standard deviation =	60 kg/sqm. for M-30 or for specified grade(s)
Design flexural strength at 28 days =	300+60x1.64 = 398.4 kg/sqm.(f +1.64 s)says 400 kg.
Water cement ratio by weight =	0.5
Minimum slump not more than 25 mm	

**16.37.2.2** For the purpose of tendering the contractor shall base his rate on the assumption that the quantity of cement used for one cum. of finished concrete shall be 340 kg. or M - 30. If the actual quantity of cement required to be used as a result of the laboratory test is different from that assumed above, necessary adjustment in the cost due to short cement used shall be made on the basis of issue rate of cement including storage charges plus 2.5% for handling charges. However, under no circumstances the quantity of cement to be used shall either exceed 350 kg./cum or fall below 330 kg. per cum of finished concrete.

**16.37.3 Statistical Field Check**

**16.37.3.1** Samples of concrete shall be taken at the mixer and works beams, made, cured and tested in accordance with IS 1199 and IS 516.

**16.37.3.2** When a mix is used for the first time, it is important to get a large number of results, as soon as possible, in order to establish the level of control and then suitability of the mix proportions. A sample of concrete shall be taken at random on eight separate occasions during each of the first five days of using that mix. From each sample two beams shall be made one for test at 7 days and the other for test at 28 days.

**16.37.3.3** The work beam results shall be examined both individually and in consecutive (but not overlapping) sets of four, for which the average and the range of each set is calculated. The mix proportions shall be modified to increase the strength, if in the first ten consecutive (but not overlapping) sets any of the following conditions are not satisfied.

(I) Each sample has a test strength not less than the minimum specified strength i.e. 30 kg/sq. cm. (or otherwise specified in item).

OR

(II) (a) Not more than two individual results (Not more than one of first twenty) of the 40 beams tests shall fall below the minimum work beam strength but they shall not be less than 80% of the specified beam strength of 30 kg./sq. cm (or otherwise specified in item) or the minimum specified strength minus 1.35 times the standard deviation whichever is greater.

(b) No value of the range in any set shall exceed 3 times the designed standard deviation.

(c) The average for all samples (10 sets) shall not be less than the minimum specified strength i.e. 30 kg/sq. cm (or otherwise specified in item) plus 1.64 times the designed standard deviation 60 kg./sq.cm M-30.

**16.37.3.4** If either of these conditions (16.37.3.3 I or 16.37.3.3 II) are not satisfied, the mix shall be modified and the procedure described above shall be repeated till results satisfying the above criterias are obtained.

**16.37.3.5** Subsequently samples shall be taken at the rate of one for every 30 cubic metre of concrete laid. Eight beam specimen shall constitute one sample. A set of 4 specimen shall be tested after 7 days and another set of 4 specimen shall be tested after 28 days. These test results shall be checked individually and in sets of four as the work progresses. If at any stage it is found that either of conditions 16.43.4.3,I or 16.4.3,II are not satisfied, the overall average and the standard deviation of the previous consecutive 40 beam test results including the non-complying set shall be calculated. If the overall average strength minus 1.64 times the standard deviation is more than the specified beam strength (30 kgm/sq.cm) (or otherwise specified in item) the concrete shall be accepted. But if it is less than the concrete work corresponding to these 40 beams tests shall be rejected and the mix proportion shall be modified forth with for further work. The rejected work shall be replaced by the contractor immediately at his own cost and expense.

**16.37.3.6** The statistical field checks described in 16.37.3.1 to 16.37.3.2 are meant to control the quality of concrete. The standard of acceptance of concrete shall be governed by the provision of para 16.37.3.3 to 16.37.3.5.

#### **16.37.4 Slump Test**

The test shall be carried out as per IS 1199. A slump test shall be carried out at each mixer at least one in fifty batches mixed or more frequently if directed by the Engineer-in-Charge. Any batch from which slump test is being made shall not be transferred to the place of laying till the slump test has been completed. Not only the batch which gives a slump in excess of that specified shall be rejected but the concrete already laid immediately preceding the batch tested up to the nearest last transverse joint may be rejected by the Engineer-in-Charge or his subordinate, if he is satisfied that such preceding batches were substandard in this respect. The decision of the Engineer-in-Charge in this respect shall be final and binding on the contractor. Such rejected concrete shall be removed by the contractor immediately and replaced with proper slump concrete at his cost and expense.

#### **16.37.5 Steel Forms**

**16.37.5.1** All side forms shall be of mild steel. The steel forms shall be of M.S. Channel sections and their depth shall be equal to the thickness of the pavement.

**16.37.5.2** The side forms shall have a length of at least 3.0 metres except on curves of less than 4.5 metres radius where shorter lengths may be used. When set to grade and stacked in place the maximum deviation of the top surface of any section from a straight line shall not exceed 3 mm. The method of connection between sections shall be such that the joint formed shall be free from play or movement in any direction. The use of bent, twisted or worn out forms shall not be permitted. At least three stake pockets for bracing pins or stakes shall be provided for each 3.0 M length of forms. Bracing and supports must be ample to prevent the springing of forms under pressure of concrete or weight or thrust of the machinery (like screed vibrator) operating on the forms. Support to the forms shall be sufficiently rigid to hold them in position during the entire operation of laying and compacting and finishing and that they shall not at any time deviate more than 3 mm from straight edge 3 metres in length. Forms which show a variation from the required rigidity of the alignment and levels shown on the plans shall be reset or removed as directed. The length and number of pins or stakes shall be such as to maintain the forms at the correct line and grade.

**16.37.5.3** The supply of forms shall be sufficient to permit their remaining in place for at least 12 hrs. after the concrete has been placed or longer, if in the opinion of the Engineer-in-Charge, it is necessary.

**16.37.5.4** The top line of the forms is not to vary from the correct level or alignment and the levels and alignment of the forms are to be checked and corrected as necessary immediately prior to the placing of concrete. The top edges and faces of the forms are to be carefully cleaned and maintained in clean condition.

**16.37.5.5** While removing the steel forms, care shall be taken to withdraw them gradually, any damage to the bull nosed edges shall be made good while the concrete is still green.

#### **16.37.5.6 Setting of Forms**

(a) Setting of forms shall be according to the slab plan subject to the approval of Engineer-in-Charge and concreting shall not commence until the setting of forms is approved.

(b) Forms shall be set for at least 50 metres in advance of the point where the concrete is being laid and shall not be removed until at least 12 hrs. of placing of the concrete or longer if in the opinion of Engineer-in-Charge is necessary.

(c) After setting, the working faces shall be thoroughly oiled by using approved oil before concrete is placed against them.

(d) The pavement joints of overlay layer would overlap with the joints of underlay cement concrete.

#### **16.37.6 Batching and Mixing**

As detailed in SH: 5 of reinforced cement concrete work of CPWD specifications 2009.

#### **16.37.7 Placing of Concrete**

As detailed in SH: 5 of reinforced cement concrete work of CPWD specifications 2009.

#### **16.37.8 Compaction of Concrete**

**16.37.8.1** Compaction shall be carried out by electrically (or) diesel operated needle and screed vibrators as stipulated hereafter. Needle vibrator should be used all over the area for obtaining initial compaction of concrete. These should be of diameter not less than 4.5 cm. If the vibrator are pneumatic the pressure must not be below 4 kg/sq.cm. If electrically operated, they should have a minimum frequency of 3500 impulses per minute.

**16.37.8.2** There should be at least three needle vibrators working in any bay. A vibrating screed consisting of a steel or timber section weighing not less than 15 kg. per metre with a tamping edge of not less than 7 cm width and having a vibrator mounted thereon shall follow needle vibrators to obtain full compaction. The face of the wooden tamping edge of the screed shall be lined with M.S. Plate rigidly fixed by means of counter sunk screw. Where screed vibrators are used for compaction, a standby unit shall always be maintained ready for use, should the other one go out of order. Where electrically driven vibrators are employed, a standby diesel pneumatic unit shall be kept ready for use in case of power failure. At the discretion of the Engineer-in-Charge, for compaction at edges and joints, vibrators may be supplemented by hand tamping and rodding for securing satisfactory results. Under no circumstances, honey combing of concrete at joints or elsewhere shall be permitted.

**16.37.8.3** When using screed vibrator for compaction it should not be dragged over the concrete. During the initial passes it shall be lifted to the adjacent forward position in short steps, subsequently, it shall be slowly slid over the surface with its axis slightly tilted away from the direction of sliding and the operation repeated until a close, dense surface is obtained.

**16.37.8.4** Concreting shall be carried out in one operation between the expansion joints and construction joints without any break at the dummy joints.

**16.37.8.5** Concrete shall be deposited on the base as near the joints as possible without touching them. It shall then be shoveled against the sides, maintaining equal pressure and deposited approx. 50 mm higher than the depth of the joints, care being taken that it is worked well around the joints. The concrete shall not be dumped from the bucket directly upon or against the joints.

**16.37.8.6** Workmen shall not be allowed to walk on freshly laid concrete and proper cat walk shall be provided with independent supports beyond concreting bays.

### **16.37.9 Finishing of Concrete**

**16.37.9.1** During compaction, any low or high spots shall be made up by adding or removing concrete. After longitudinal floating has been completed but while concrete is still plastic, the slab surface shall be tested for trueness with a 3 m straight edge. Any depressions or high spots showing departure from the true surface shall be immediately rectified. High spots shall be cut down and refinished. Depressions shall be enlarged to about 8-10 cm and filled up with fresh concrete, compacted and finished.

**16.37.9.2** The straight edge testing the refloating is to continue until the entire surface:

- (a) is free from observable departure from the straight edge,
- (b) conforms to the required levels and across section, and
- (c) shall conform to the specified surface when the concrete has hardened.

**16.37.9.3** The foregoing work is to be carried out while the concrete is still plastic and workable.

### **16.37.10 Belting**

**16.37.10.1** Just before concrete becomes non-plastic, the surface shall be belted with a two ply canvas belt not less than 20 cm wide and at least 1 metre longer than the width of the slab. Hand belts shall have suitable handles to permit controlled uniform manipulation. The belt shall be operated with short strokes transverse to the centre line of the pavement and with rapid advance parallel to the centre line.

### **16.37.11 Brooming**

**16.37.11.1** After belting and as soon as the surplus water, if any, has risen to the surface, the pavement shall be given a broom finish with an approved steel or fiber broom not less than 45 cm wide. The broom shall be pulled gently over the surface of the pavement from edge to

edge. Adjacent strokes shall be slightly overlapped. Brooming shall be perpendicular to the centre line of the pavement and so executed that the corrugations formed shall be uniform in character and width and not more than 1.5 mm deep.

**16.37.11.2** Brooming shall be completed before the concrete reaches such a stage that the surface is likely to be torn or unduly roughened by the operation. The broomed surface shall be free from porous or rough spots, irregularities, depressions, and small pockets such as may be caused by accidental disturbing of particles of coarse aggregates embodied near the surface. The brooming shall be of uniform pattern all through.

**16.37.11.3 Edging :** After belting/brooming has been completed but before the initial setting of concrete, the edges of the slab shall be carefully finished with an edger of 6 mm radius, and the pavement edges shall be left smooth and true to line.

#### **16.37.12 Honey Combing**

**16.37.12.1** The side forms shall not be removed until 12 hours or such longer period as the Engineer-in- Charge may decide after the laying of concrete.

**16.37.12.2** As soon as the side forms are removed, any minor honey combed area shall be filled with mortar composed of one part of cement and two parts of fine aggregate. Major honey combing areas or segregated concrete or other defective work or areas damaged by removal of the forms or concrete damaged by rain or due to any other reason whatsoever shall be considered as defective work and shall be removed and replaced by the contractor at his own expense. The total area of honey combed surface shall not exceed 4 per cent of the area of the slab side. However, no individual honeycomb patch shall exceed 0.1 sqm. Engineer-in-Charge's decision as to whether the concrete is defective or not shall be final and binding.

#### **16.37.13 Surface Accuracy**

**16.37.13.1** After the concrete has sufficiently hardened after about 12 hours and not later than 24 hours, the surface shall be tested again for high spots. All high spots shall be marked and those exceeding 3 mm shall be ground down immediately. Care shall be taken to see that the grinding does not in any way damage the concrete surface.

**16.37.13.2** The final surface finish is to be such that when tested with a profilograph/roughness indicator/or a 3 metre long straight edge or an equivalent mechanical unevenness indicator placed anywhere within the same or adjoining slab in any direction on the surface, there shall be no variation greater than 3 mm.

**16.37.13.3** If the surface irregularity exceeding 3 mm still remains despite grinding as per para 16.37.13.2 the concrete shall be removed to its full depth. The area of concrete to be removed shall be complete slab between the nearest joints, where the defective slab is less than 4.5 metres from the expansion joint, the whole area upto the expansion joint shall be removed to the full depth. The concrete so removed shall not be reused in the work. Fresh concrete shall be laid in the manner already described in above paras and shall again be subject to test for surface accuracy and other quality control measures. Nothing extra shall be paid on this account.

**16.37.13.4** Every slab shall bear an impression not exceeding 3 mm in depth comprising the number allotted to the slab and the date on which it is laid. This impression shall be formed by the contractor when the concrete is green so as to leave permanent mark on setting.

#### **16.37.13.5 Initial Curing**

**16.37.13.5.1** Immediately after completion of the finishing operations, the surface of the pavement shall be entirely covered with wetted burlap, cotton or jute mats. The mats used shall be of such length (or width) that as laid they shall extend at least 45 cm beyond the edges of the slab. The mats shall be placed so that the entire surface and both edges of the slab are completely covered. This covering shall be placed as soon as, in the judgment of the Engineer-in-Charge the concrete has set sufficiently to prevent damage to the surface prior to being placed, the mats shall be thoroughly saturated with water and shall be placed with the wettest side down. The mats shall be so placed and weighed down as to cause them to remain in intimate contact with the surface covered, and the covering shall be maintained full wetted and in position for 24 hours after the concrete has been placed or until the

concrete is sufficiently hard to be walked on without suffering damage. Water shall be gently sprayed so as to avoid damage to the fresh concrete. If it becomes necessary to remove a mat for any reason, the concrete slab shall not be exposed for a period of more than half an hour.

**16.37.13.5.2** Worn burlap or burlap with holes shall not be permitted. Burlap reclaimed from previous use other than curing concrete shall be thoroughly washed prior to use for curing purposes. If burlap is obtained in strips, shall be laid to overlap by at least 150 mm.

**16.37.14** Burlap shall be placed from suitable bridges. Walking on freshly laid concrete to facilitate placing burlap shall not be permitted.

#### **16.37.15 Final Curing**

**16.37.15.1** Upon the removal of the burlaps, the slab shall be thoroughly wetted and then cured as follows:-

All joints shall be filled with filler in order to prevent the edges of joints from getting damaged and entry of clay materials into the joints during final curing. Exposed edges of the slab shall be banked with a substantial berm of earth. Upon the slab shall then be laid a system of transverse and longitudinal dykes of clay about 50 mm high immediately covered with a blanket of sandy soil free from stones to prevent the drying up and cracking of clay. The rest of slab shall then be covered with sufficient sandy soil so as to produce a blanket of earth not less than 40 mm deep after wetting. The earth covering shall be thoroughly wetted while it is being placed on the surface and against the sides of the slab and kept thoroughly saturated with water for 21 days and thoroughly wetted down during the morning of the 22<sup>nd</sup> day and shall thereafter remain in place until the concrete has attained the required strength and permission is given by the Engineer-in-Charge. Thereafter the covering shall be removed and the pavement cleaned and swept. If the earth covering becomes displaced during the curing period, it shall be replaced to the original depth and re-saturated.

**16.37.15.2** Contractor shall appoint chowkidars at his expense to prevent workmen, cattle, etc., straying on the pavement concrete.

**16.37.15.3** Concrete shall not be subjected to any load or weight of any plant until at least 28 days after laying.

#### **16.37.16 Construction Joints**

**16.37.16.1** Construction joints shall be provided as shown in the drawing and also at places where concreting is stopped due to unforeseen circumstances. The joints shall be straight and vertical through the full thickness of the slab. While concrete in adjacent bay is still green, flats of suitable size shall be drawn along the edge and a groove of size 10 mm × 25 mm deep shall be neatly formed and finished. The edges of the groove shall be full nosed. After curing of concrete is complete, this groove shall be thoroughly cleaned of all sand dust and shall be perfectly dried and filled with hot poured sealing compound conforming to grade B of IS 1834. Before filling with sealing compound the faces of concrete of the joint shall be coated with primer of approved brand to a depth of 25 mm at the rate of 2.6 liters per 10 square meters. Bitumen emulsion shall not be used as primer.

#### **16.37.17 Dummy Joints**

**16.37.17.1** The joints shall be 10 mm wide and shall extend vertically from the surface of the slab to a depth equal to 1/3rd of the thickness of the slab but not less than 4 cm in any case. The joint may be formed by depressing into the soft but compacted concrete a high tensile M.S. or other approved Tee of flat bar of depth not less than required depth of the joint plus 25 mm. The bar used for forming the groove shall be coated with soft soap or other suitable lubricant to facilitate its removal when the steel Tee or flat is removed joints shall be neatly formed with proper tools and mortar/fine material from the slab itself. No additional cement mortar (rich or otherwise) shall be used.

**16.37.17.2** Cutting or sawing by a saw mounted on a movable frame and driven mechanically shall also be permitted as a method for making the joint. In this case the width may be reduced to 6 mm. any other method for making joints can be followed with the prior approval of the Engineer-in-Charge.

**16.37.17.3** In all cases, except where cutting is done with saw, the joint edges shall be bull nosed. Care should be taken to see that the edges of the grooves are not damaged.

**16.37.17.4** The grooves shall be filled with hot poured sealing compound conforming to Grade B of IS:1834. Prior to filling with sealing compound, the joints shall be cleaned by compressed air and primed with Shalijet primer or equivalent at the rate specified in Para 16.37.16.1

**16.37.17.5** All joints shall be sealed as soon as practicable after 28 days of casting of cc pavement. Joints shall be sealed flush with the adjacent pavement surface in summer and 3-4 mm below finished concrete surface in winter. The pavement shall be opened to traffic only after joint sealing over the entire pavement. To prevent tackiness or pickup under traffic, the exposed surfaces of the sealing compound shall be dusted with hydrated lime, if directed by Engineer-in-Charge, for which nothing extra shall be paid to the contractor.

**16.37.17.6** In case of sudden rain or storm, the work can be concluded at the dummy joints but these will then be formed as construction joints.

**16.37.17.7** Before sealing of joints, it may be ensured that the groove extends fully across the bay between consecutive longitudinal joints, in the case of transverse joints and is continuous in the case of longitudinal joints. Any concrete or other foreign matter must be removed from the groove.

#### **16.37.18 Concreting during Rains**

**16.37.18.1** To prevent damage to freshly laid concrete during monsoon, or sudden rains, the contractor shall provide an adequate supply of tarpulines or other water proof covering material. Any concrete damaged by rain shall be removed and replaced by the contractor at his own cost as directed by the Engineer-in-Charge.

#### **16.37.19 Quality Control**

The following quality control tests shall be carried out at frequencies specified against each as in Table 16.33.



TABLE 16.33

S. No.	Test	Test Method	Frequency	Acceptance Criteria
1	2	3	4	5
(i)	<b>COARSE AGGREGATE</b>			
(a)	Flakiness index.	IS 2386 (Pt.I)	Before approval of the quarry and at every subsequent change in the source of supply and one test per 100 cum of aggregates	Not more than 15%
(b)	Impact value.	IS 2386 (Pt.IV)	-do-	Not more than 30%
(c)	Los angles abrasion value.	IS 2386 (Pt.IV)	-do-	Not more than 40%
(d)	Deleterious materials.	IS 2386 (Pt.II)	Before approval of the quarry and at every subsequent change in the source of supply	As per table 1 of IS 383
(e)	Moisture content.	IS 2386 (Pt.III)	Regularly as required subject to a min. one test per day	-do-
(ii)	<b>FINE AGGREGATES</b>			
(a)	Silt content.	CPWD specifications 2009, Vol. I, SH: CC	One test per 15 cum	Not more than 8%
(b)	Gradation of sand	IS 2386 (Pt.I)	-do-	Fineness modulus between 2.5 to 3.9
(c)	Deleterious materials.	IS 2386 (Pt.II)	Before approval of the quarry and at every subsequent change in the source of supply	As per table 1 of IS 383
(d)	Moisture content.	IS 2386 (Pt.III)	Regularly as required subject to a min. 2 test/day.	
(iii)	<b>MIXED AGGREGATES</b>			
(a)	Grading	IS 2386 (Pt. I)	1 test per 15 cum	As per para 16.37.1.5

### 16.37.20 Equipments

**16.37.20.1** Equipments as per list at Appendix C shall be provided by the contractor in the field testing laboratory. Nothing extra shall be paid to him on this account. Records as required shall be maintained at site. All tests details in support of mix design shall be maintained as part of records of the contract and shall be signed both by the contractor and the Engineer-in-Charge. The contractor shall provide all labour, materials and equipment required for all tests to be carried out at his own cost.

**16.37.20.2** The Engineer-in-Charge reserves the right to test any part of concrete laid regarding quality soundness, compactness, thickness, strength and finish of the concrete, at any time before the expiry of the "Defect liability period" notwithstanding that necessary tests had been carried out and found satisfactory at the time of execution.

**16.37.20.3** All defective unsound sub-standard work and concrete of sub-standard strength and quality etc. as established vide paras 16.37.3 shall be rejected and shall be replaced by the contractor at his own expense in the manner as detailed in para 16.37.3. Where due to operational or any other reason such replacement does not become possible (decision of Engineer-in-Charge in this respect being final and binding on the contractor), the cost of removal and replacement of such rejected work shall be recovered from the contractor whether such rejected work is subsequently replaced by the Government or not.

### 16.37.21 Defects Liability Period

**16.37.21.1** This period shall be reckoned in the case of this work as one year from the date of completion of work and it shall be the liability of the contractor to repair, strengthen or reconstruct any portion of the work which has shown damage or any defect, arising out of

any bad workmanship or defective material used in the work during this period. In the case of this rectification not being commenced by the contractor within 7 days from the date of notice from the Engineer-in-Charge and completed expeditiously the Engineer-in-Charge reserves the right to get the repair work executed at the risk and cost of the contractor.

#### **16.37.22 Measurements**

**16.37.22.1** For the purpose of ascertaining the quantity of concrete in the pavement, thickness shall be measured by means of a scale correct to the nearest 2 mm. The thickness of the concrete pavement slabs shall be taken on either side of the pavement at each dummy joint at four corners of the slab immediately after removal of the side forms. In case the average thickness of the slab exceeds the specified thickness, payment shall be restricted to the specified thickness.

**16.37.22.2** The dimensions of each slab of pavement shall be measured as follows to the nearest 5 mm.

(a) **Length**

- (i) Between the end of a pavement to the centre line of the expansion joints.
- (ii) Between the centre lines of consecutive expansion joints.

(b) **Width**

- (i) Between the edge of a pavement and the centre line of the construction joints.
- (ii) Between the centre lines of construction joints and expansion joints.
- (iii) Between the centre lines of consecutive construction joints.

**Note :** The quantity of concrete in the pavement slab shall be worked out by multiplying the area of the slab and its average thickness or specified thickness whichever is less. No deduction shall be made for any joints in the concrete slab.

**16.37.22.3** Measurements of concrete slabs shall be recorded jointly by the Engineer-in-Charge or his authorized subordinate and the contractor or his authorized agent.

#### **16.37.23 Rate**

The rate of the item for concrete in pavement shall include the cost of all materials and labour including charges for machinery tools & plants required in all the operations described above. The rate also includes all cost of setting up the laboratory at site and carrying out the quality control measures/tests enumerated above by the contractor at his own cost in the presence of Engineer-in-Charge or his authorized representative and submission of test results on completion of tests to the Engineer-in-Charge thereof.

#### **16.38 HARD CRETE**

Hard crete of approved quality and brand to be used. It shall be mixed in ratio and method as recommended by manufacturer and approved by Engineer-in-charge in cement concrete for laying in paramount. Quantity shall be measured in litre used in cement concrete. Hardcrete to be brought in sealed container and proper record of quantity be maintained. Empty containers of hardcrete shall not be removed from site with but prior permission of Engineer-in-Charge.

#### **16.39 EXPANSION JOINT**

##### **16.39.0 Materials**

**Premoulded Joint Filler in Expansion Joint :** It shall conform to IS 1838 (Pt. I). The thickness shall be 25 mm with tolerance 1.5 mm. and shall be of the maximum available standard length not less than one lane width. The filler board shall be positioned vertically with the prefabricated joint assemblies along the line of the joint within tolerance of + 10 mm from the intended line of the joint. The depth of board shall be 25 mm less than thickness of slab within a tolerance of  $\pm 3$ mm so that the top of the board shall be below the surface or will not impend the passage of the finishing straight edge or oscillating beam of the paving machine.

**Bitumine Hot Sealing Compound :** The joint sealing compound shall be fuel and heat resistant type complying to grade B of IS 1834. It shall be capable of adhering to the concrete without cracking, spalling and disintegration.

#### **16.40 CONSTRUCTION PROCEDURE**

**16.40.1** Expansion joints shall be provided as shown in the drawing and as per directions of Engineer-in- Charge. All joints shall be constructed true to line with their faces perpendicular to the surface of the pavement. The joint shall be 20 mm wide. The depth of the non-extruding filler pad shall be 25 mm less than the depth of the concrete slab.

**16.40.2** Before the provision of expansion joint, the face of the already laid concrete slab shall be painted with primer at the rate of 2.6 liters per 10 square metres. The expansion pad shall be properly cut to shape and shall then be placed in position abutting the painted face of the already laid concrete slab. The adjacent slab shall then be concreted. The face of the pad against which the new concrete slab is to be laid shall also be painted with primer before laying the concrete, while concreting a neat groove of size 20 mm x 25 mm as per drawing shall be formed on top of the pad taking care that the edges are absolutely straight and that the groove so made does not get filled with any material like concrete, mortar and other rubbish.

**16.40.3** Before the curing process is started, the top of expansion joint shall be filled with bitumen sand mixture in order to ensure that no foreign material used in curing enters into the joint. This filling shall be removed before filling the joints with sealing compound.

**16.40.3.1** For sealing the joints following operations shall be carried out :—

- (a) The joints are cleared of any foreign matter to the full depth upto the top of expansion pad with steel spatula.
- (b) The joints are blown with compressed air.
- (c) Cleaning is done with Kerosene oil.
- (d) Priming is done with spray gun @ 2.6 liters per 10 sqm of the surface to be primed.
- (e) The primer is allowed to dry completely before pouring the sealing compound.
- (f) The sealing compound grade 'A' is heated to the required temperature ranging between 155 deg. C to 165 deg. C or to the temperature range specified by the manufacturer. Over heating shall be avoided. Pouring shall be done from vessel with spout in such a manner that the material will not get spilled on the exposed surface of the concrete, any excess filler on the surface of the pavement shall be removed immediately and the pavement surface cleaned.
- (g) The filling shall be worked into the joints with hot flats to ensure escape of trapped air.
- (h) The filling is then ironed with hot iron. It is recommended that while in summer the joints may be sealed flush with the adjacent pavement surface, in winter the sealing compound may be filled to a depth 3-4 mm below the surface.
- (i) The edges of the joints are then cut and trimmed to ensure neat and straight line finish.
- (j) To prevent tackiness or pick up under traffic, the exposed surfaces of the sealing compound shall be dusted with hydrated lime, if directed by Engineer-in-Charge (Nothing extra shall be paid for the same).

**16.40.3.2 Measurements :** The measurement of the specified depth of joint shall be recorded in metres correct to two places of decimals.

#### **16.40.4 Rate**

Rate for the item shall include the cost of all materials, plant, machinery and labour involved in all operations described above, including all cartages and lifts.

### **16.41 PAINTING ROAD/ RUNWAYS MARKINGS**

#### **16.41.1 Materials**

**16.41.1.1** Special Road marking paint of approved brand and manufacture shall be used. The paint shall conform to IS 164. Ready mixed paint as received from the manufacturer shall be used without adding any admixture.

**16.41.1.2** During work, if the consistency of the paint gets thick and thinning becomes necessary it shall be done by use of thinner of the approved brand of paint recommended by the manufacturer and with the approval of the Engineer-in-Charge.

**16.41.1.3** The paint shall be brought to the site of work by the contractor in original sealed containers. The material shall be brought in one lot in adequate quantity to suffice for the entire work. The material shall be kept in the joint custody of the contractor and the

Engineer-in-Charge. The empty container shall not be removed from the site of work, till the work has been completed and permission obtained from the Engineer-in-Charge.

#### **16.41.2 Preparation of Surface**

The surface shall be thoroughly cleaned and free from dust. All the dirt, scales, oil and grease shall be thoroughly removed before painting is started. The prepared surface shall be inspected and approved by the Engineer-in-Charge before painting is commenced.

#### **16.41.3 Application**

**16.41.3.1** Before pouring into smaller containers for use, the paint shall be stirred thoroughly in its original container. The paint shall be continuously stirred in the smaller container while applying to runway surface so that its consistency is kept uniform.

**16.41.3.2** The painting shall be applied evenly and smoothly by means of crossing and laying off. The crossing and laying off consists of covering the area over with paint, brushing the surface hard for the first time over and then brushing alternatively in opposite direction, two or three times and then finally brushing lightly in a direction at right angle to the same. In this process, no brush marks shall be left after the laying off is finished. The full process of crossing and laying off will constitute one coat.

**16.41.3.3** Each coat shall be allowed to dry out thoroughly before the next coat is applied.

**16.41.3.4** Earlier applied coat shall be cleaned off dust before the next coat is laid.

**16.41.3.5** No left over paint shall be put back into the stock tins. When not in use, the containers shall be kept properly closed.

**16.41.3.6** No hair marks from the brush or clogging of paint puddles shall be left on the work.

**16.41.3.7** The surface shall ordinarily not be painted until it has dried up completely. Trial patches of paint shall be laid at intervals to check if drying is satisfactory.

**16.41.3.8** The runway marking shall be done in accordance with the drawing unless otherwise instructed by the Engineer-in-Charge.

#### **16.41.4 Brushes and Containers**

**16.41.4.1** After work, the brushes shall be completely cleaned of paint by rinsing with turpentine. A brush in which paint has dried up is spoiled and shall on no account be reused for painting work. On no account kerosene oil shall be used for washing the brush.

**16.41.4.2** When the paint has been used, the containers shall be washed with turpentine and wiped dry with soft clean cloth so that they are clean, and can be used again.

#### **16.41.5 Measurement**

**16.41.5.1** Length and breadth shall be measured correct to a cm. Area shall be worked out in square metre, correct to two places of a decimal.

#### **16.41.6 Rate**

**16.41.6.1** Rate shall include cost of all materials, tools and labour involved in all the operations described above including all cartages and lifts.

### **16.57 FACTORY MADE CEMENT CONCRETE INTERLOCKING PAVER BLOCK**

#### **16.57.1 Base**

Interlocking paver block to be fixed on the bed 50 mm or specified otherwise thick of coarse sand of approved specification and filling the joints with the sand of approved type and quality or as specified and as directed by Engineer-in-charge.

#### **16.57.2 Interlocking Paver Block**

Factory made precast paver block of M-30 or otherwise specified grade to be used. Paver blocks to be of approved brand and manufacturer and of approved quality. Minimum strength as prescribed by manufacturer and as per direction of Engineer-in-Charge for the grade specified to be tested as per method mentioned in specification of subhead cement concrete of CPWD Specification 2009 Vol. I.

#### **16.57.3 Measurement & Rates**

Area provided with paver block to be measured in sqm. correct upto two places of decimal. The rate include the cost of the material, labour, tools etc. required in all the operations described above.

### **16.58 KERB STONE (PRECAST)**

### **16.58.1 Laying**

**16.58.1.1** Trenches shall first be made along the edge of the wearing course of the road to receive the kerb stones of cement concrete of specified grade. The bed of the trenches shall be compacted manually with steel rammers to a firm and even surface and then the stones shall be set in cement mortar of specified proportion.

**16.58.1.2** The kerb stones with top 20 cm. wide shall be laid with their length running parallel to the road edge, true in line and gradient at a distance of 30 cm. from the road edge to allow for the channel and shall project about 12.5 cm. above the latter. The channel stones with top 30 cm. wide shall be laid in position in chamber with finished road surface and with sufficient slope towards the road gully chamber. The joints of kerb and channel stones shall be staggered and shall be not more than 10 mm. Wherever specified all joints shall be filled with mortar 1:3 (1 cement : 3 coarse sand) and pointed with mortar 1:2 (1 cement: 2 fine sand) which shall be cured for 7 days.

**16.58.1.3** The necessary drainage openings of specified sizes shall be made through the kerb as per drawings or as directed by the Engineer-in-Charge for connecting to storm water drains.

### **16.58.2 Finishing**

Berms and road edges shall be restored and all surplus earth including rubbish etc. disposed off as directed by the Engineer-in-charge. Nothing extra shall be paid for this.

### **16.58.3 Measurements**

It shall be measured in cubic meters with Length of the finished work (for specified width and height of stone) shall be measured in running metre along the edge of the road correct to a cm.

### **16.58.4 Rate**

The rate shall include the cost of all the materials and labour involved in all the operations described above.

**Note:- For further detail refer CPWD specification volume 2, Sub Head 16.0**

## SUB HEAD : 17.0 SANITARY INSTALLATIONS

### 17.0 TERMINOLOGY

#### **Antisiphon Pipe (Fig. 17.1)**

A ventilating pipe connected to or close to the outlet side of a trap seal.

#### **Automatic Flushing Cistern (Fig. 17.3)**

A flushing cistern arranged to discharge its content by siphonage at regular intervals, determined by the rate at which water is fed into the cistern.

#### **Ball Cock (Fig. 17.3)**

A faucet opened or closed by the fall or rise of a ball floating in the surface of water.

#### **Ball Valve (Fig. 17.3)**

A simple non return valve consisting of a ball resting on a cylindrical seat within a fluid passageway.

#### **Bell Mouth (Fig. 17.3)**

An expanded rounded entrance to a pipe or orifice.

#### **Bend**

Length of pipe bent or cast into an angle shape.

#### **Bib Tap**

A tap with a horizontal inlet and nozzle bent to discharge in a downward direction.

#### **Blister**

A raised portion of the surface protruding not more than one millimeter above the surface and not greater than 3 mm in its greatest dimension.

#### **Box Union**

A device for joining two threaded pipes.

#### **Branch (Fig. 17.1)**

(a) A special form of vitrified sewer and cast iron pipe used for making connections to a sewer or water main. The various types are called T, Y, T-Y, double Y, and V branches, according to their respective shapes.

(b) Any part of piping system other than a main.

#### **Caulking**

(a) The process of driving, pouring or forcing lead, oakum, plastic or other material into a joint to make it leak proof.

(b) The material used in the caulking process.

#### **Caulked Joint**

A spigot and socket joint in which the jointing material is compacted by means of caulking tool and hammer.

#### **Chase**

A continuous recess in wall, floor or ceiling for the purpose of holding pipes and conduits.

#### **Cistern (Fig. 17.3)**

A fixed container for water in which the water is at atmospheric pressure. The water is usually supplied through a ball valve.

#### **Collar**

A pipe-fitting in the form of sleeve for jointing the spigot ends of two pipes in the same alignment.

#### **Cowl (Fig. 17.1)**

A hood on the top of a vent pipe or soil stack.

#### **Craze or Crazing**

Fine cracks in the glaze.

#### **Cross**

A pipe fitting used for connecting four pipes at right angles.

#### **Fittings**

Coupling, flange, branch, bend, tee, elbow, union, waste with plug, P or S trap with vent, ferrule, stop tap, bib tap, pillar tap, globe tap, ball valve, cistern, storage tank, baths, water

closets, boiler geyser, pumping set with motor and accessories, metre, hydrant valve and any other article used in connection with water supply, drainage and sanitation.

**Float Valve (Fig. 17.3)**

A valve in which the closure to an opening such as a plug or gate, is actuated by a float to control the flow in to a tank.

**Flush Bend**

A bend located at the bottom of low level flushing cistern for the purpose of flushing pedestal type water closet and similar fixture.

**Flushing Cistern (Fig. 17.3)**

A cistern provided with a device for rapidly discharging the contained water and used in connection with a sanitary appliance for the purpose of cleaning the appliance and carrying away its contents into a drain.

**Gasket**

A piece of compressible material used to make a joint between two flat surfaces.

**Oakum**

Hemp or old hemp rope soaked in oil to make it water proof.

**One Pipe System (Fig. 17.1)**

In this a single soil waste pipe conveys both soil and waste directly to the building drain.

**Pinhole**

A hole in the body, less than 1.5 mm, in its maximum dimension.

**Reducer**

A pipe-fitting with inside threads larger at one end than at the other. All such fittings having more than one size are reducers because of the custom of stating the larger size first.

**Single Stack System (Fig. 17.1)**

This is the name given to a simplified one pipe system wherein all ventilation pipes are omitted. The stack itself is made to cater (or provide) for all the vent requirements by restricting the flow into the stack to certain predetermined limits.

**Sink (Fig. 17.7)**

A shallow fixture, ordinarily with a flat bottom, that is usually used in kitchen or in connection with the preparation of food, laboratory purposes and for certain industrial processes.

**Socket**

The female part of spigot and socket joint.

**Soil Pipe**

A pipe which conveys to drain the discharge from a water closet or urinals. In 'One pipe' and 'single stack' system the soil pipe also conveys to a drain the discharges from bath, wash basins, sinks and similar appliances.

**Speck**

Area of the finished surface with contrasting colour less than one millimeter maximum dimension.

**Spigot**

The male part of a spigot and socket joint.

**Spigot and Socket Joint**

Joint in which the end of the one pipe enters the enlarged end of the next pipe.

**Stack**

A main vertical discharge or ventilating pipe.

**Trap**

A fitting or device so designed and constructed as to provide, when properly vented, a liquid seal which will prevent the back passage of air without materially affecting the flow of sewage or waste water through it.

**Two Pipe System (Fig. 17.1)**

In this, the soil pipe conveys discharges from water closets, urinals, and similar soil appliances directly to the drainage system and the waste pipe conveys waste from

ablutionary and culinary appliances to the drainage system directly or through a trapped gully where desired.

**Union**

A pipe fitting used for joining the ends of two pipes neither of which can be turned.

**Valve**

A device used for controlling the flow of liquid in a line of pipe.

**Ventilating Pipe (Vent Pipe)**

The pipe which provides a safe outlet into the atmosphere for the foul gases in the drain or sewer.

**Warpage**

Distortion of original shape during manufacturing process.

**Water Seal**

The depth of water which should be removed from a fully charged trap before air can pass through the trap.

**Waste Pipe**

A pipe used to convey liquid waste not containing human excreta.

**Waste Stack**

A vertical pipe used to convey liquid waste not containing human excreta.

**17.1 APPLIANCES AND FITTINGS**

**17.1.0** All vitreous sanitary appliances (Vitreous China) shall conform to IS 2556 (Part-I) general requirements.

**17.1.1 Flushing Cisterns (Fig. 17.3)**

The flushing cisterns shall be automatic or manually operated high level or low level as specified, for water closets and urinals. A high level cistern is intended to operate with minimum height of 125 cm and a low level cistern with a maximum height of 30 cm between the top of the pan and the under side of the cistern. Cisterns shall be of following type (i) Vitreous China (IS 774) for Flushing type (ii) Automatic Flushing Cistern (IS 2326) and (iii) Plastic cisterns (IS 7231).

**17.1.1.1 Vitreous Chine Cisterns :** The thickness of the body including cover shall be not less than 6 mm for vitreous China cisterns. The outlet of each syphon or stand pipe shall be securely connected to the cistern by means of lock nut. The cistern shall be free from manufacturing faults and other defects affecting their utility. All working parts shall be designed to operate smoothly and efficiently. Cistern shall be mosquito proof. A cistern shall be considered mosquito proof only if there is no clearance any where which would permit a 1.6 mm wire to pass through in the permanent position of the cistern i.e. in the flushing position or filling position. The breadth of a low level cistern, from front to back shall be such that the cover or seat, or both, of water closet pan shall come to rest in a stable position when raised. The cistern shall be supported on two cast iron brackets of size as approved by the Engineer-in-Charge and embedded in cement concrete 1:2:4 block 100 x 75 x 150 mm. These shall be properly protected by suitable impervious paint. Alternatively the cisterns shall have two holes in the back side above the overflow level for screwing into the wall, supplemented by two cast iron wall supports. A 5

litres cistern, however, may be supported by larger brackets cast on the body of the cistern. The cistern shall have a removable cover which shall fit closely on it and be secured against displacement. In designs where the operating mechanism is attached to the cover this may be made in two sections, but the section supporting the mechanism shall be securely bolted or screwed to the body. The outlet fitting of each cistern shall be securely connected to the cistern. The nominal internal diameter of cistern outlet shall be not less than  $38 \pm 1$  mm for low level cisterns respectively. The length of the outlet of the cistern shall be  $37 \pm 2$  mm. Ball valve shall be of screwed type 15 mm in diameter and shall conform to IS 1703. The float shall be made of polyethylene as specified in IS 9762. (The design shall permit the cistern to fill in rapidly and close effectively when the level of water reaches the working water level.) In the case of manually operated cisterns the siphonic action of the flushing cistern shall be capable of being rapidly brought into action by the operating lever, but shall



not self siphon or leak. When tested according to IS 774 the discharge rate shall be  $10 \pm 0.5$  litre in 6 seconds and  $5 \pm 0.5$  litre in 3 seconds for cisterns of capacities 10 litre and 5 litre respectively. The cisterns shall be so designed that there is not appreciable variation in the force of flush during the discharge of the required quantity of water. The cistern shall have a discharge capacity of 5 & 10 litres as specified. When required to give a full flush, they shall respectively discharge 5 litres and 10 litres with variation of  $\pm 0.5$  litres. The flush pipe shall be of (a) medium quality galvanised iron having internal diameter of  $38 \pm 1$  mm for low level cistern. The flush pipe shall be of suitable length with bends etc. as required for fixing it with front or back inlet W.C. Pan. (b) Polyethylene pipes low density conforming to IS 3076 or high density (c) Unplasticised PVC pipes. For high density polyethylene and unplasticised PVC pipes, the outside diameter of the pipes shall be 40 mm. When PVC plumbing pipes are used the outside diameter of the pipe shall be 40 mm for high level cisterns and 50 mm for low level cisterns. In case of low level cistern the flush pipe shall be a vertical pipe 30 cm long and having a nominal internal dia  $38 \pm 1$  mm (except plastic flush pipes).

**Over Flow Pipe**

(a) GI overflow pipe shall be of not less than 20 mm nominal bore and shall incorporate a noncorrodible mosquito proof brass cover having 1.25 mm dia perforation, screwed in a manner which will permit it to be readily cleaned or renewed when necessary. No provision shall be made whereby the overflow from the cistern shall discharge directly into the water closet or soil pipe without being detected. The invert of the overflow pipe in the case of high level and low level cisterns shall be 19 mm minimum above the working water level. In case of overflow due to any reason water should drain out through the over flow pipe and not through the siphon pipe.

(b) The plastic overflow pipes shall be manufactured from high density polyethylene conforming to IS 4984 or unplasticised P.V.C. conforming to IS 4985.

**Inlet and Overflow Holes:** The cistern shall be provided with inlet and overflow holes, situated one at each end which shall be capable of accommodating an overflow pipe of not less than 20 mm nominal bore and a 15 mm size ball valve. The holes shall be cleanly cast or drilled and the adjacent surfaces shall be smooth.

**17.1.1.2 PVC Cisterns :** Plastic flushing cisterns for WC and Urinals shall be as per IS 7231. The materials for manufacturing various components of the flushing cisterns shall conform to the requirements given in Table 17.1 below:

**TABLE 17.1  
Materials for Various Components of Flushing Cisterns**

Sl. No. (1)	Component(s) (2)	Material (3)	Conforming to (4)
1.	Cisterns	High density polyethylene (HDPE) Or Polystyrene, high impact Or Polypropylene <sup>1)</sup> Or Acrylonitrile-butadiene-styrene (ABS) Or Glass Fibre reinforced plastic (GRP)	IS 7328  IS 2267  - - -
2.	Flush pipe	Steel tube, seamless or welded, medium or light, completely protected inside and outside by hot-dip galvanizing, electroplating or vitreous enamelling Or Lead pipe Or Copper alloy tube Or High density polyethylene pipe Or Unplasticised PVC plumbing pipe	IS 1239 ((Part 1)  IS 404 (Part 1) IS 407 IS 2501

(1)	(2)	(3)	(4)
3.	Cover	Same material as that of the body	
4.	Chain	Hot-dip galvanized steel wires Or Inter-locked non-ferrous metal Or Any other corrosion resistant material	-
5.	Overflow pipe	High density polyethylene Or Unplasticised PVC Or Any other corrosion-resistant material	IS 4984 IS 4985
6.	Siphon/Valve	High density polyethylene Or Polystyrene, high impact Or Polypropylene Or Acrylonitrile- butadiene-styrene Or Glass fibre reinforced plastic (GRP)	IS 7328 IS 2267 - -
7.	Operating Mechanism/ Lever	Non-ferrous metal or any other corrosion-resistant material	-
8.	Float valve	As specified in IS 1703 Or IS 12234 Or IS 13049	
9.	Polyethylene float for float valve	As specified in IS 9762	-
10.	Coupling nut and lock-nut	Non-ferrous metal, Or Hot-dip galvanised steel Or Hot-dip galvanised malleable iron Or Any other non-corrosive metal Or Injection-moulded HDPE/polyacetal	-

1) Talc as filler, if used shall not exceed 20%

**Note:** Where the requirements for the material of any component or the relevant Indian Standard designation for any material are not specified, these shall be as directed by the Engineer-in- Charge. The thickness of the body including cover at any point shall not be less than 2 mm for GRP, and not less than 3 mm for other plastic materials. The cistern shall be free from manufacturing faults and other defects affecting its utility. All working parts shall be designed so as to operate smoothly and efficiently. The cistern shall be mosquito-proof. It shall be deemed to be mosquito proof only when there is no clearance anywhere in it which would permit a 1.6 mm diameter wire to pass through. The outlet of each siphon or stand pipe or flush valve shall be securely connected to the cistern by means of a lock nut. In the case of plastic siphon, it shall be provided with suitable means of ensuring and maintaining watertight and airtight joint to the cistern. The cistern shall be provided with a removable cover which shall fit closely and shall be secured against displacement. In designs, where the operating mechanism is attached to the cover, the cover may be made in two sections, the section supporting the mechanism being securely fixed or booked to the body. The flush pipe (except plastic flush pipe) shall have an internal diameter of 32 + 1 mm for high level cistern and 38 + 1 mm for low level cistern. The steel flush pipe shall be not less than 1 mm thick whereas the lead flush pipe shall have a minimum thickness of 3.5 mm. For high density polyethylene pipes, the outside diameter of the pipes shall be 40 mm. For unplasticised PVC plumbing pipes the outside diameter of the pipe shall be 40 mm for high level cisterns, and 50 mm for low level cisterns. In the case of high level flushing cisterns, a pipe clip fitted with a rubber buffer shall be fixed to the flush pipe to prevent damage either to the pipe or to the seat when the seat is raised. No flush pipe is required for coupled cisterns.

**Note:** The minimum thickness specified is for normal conditions of service. Where highly corrosive atmospheres are expected, greater thicknesses are required to be provided as per nomenclature of the item.

#### ***Flush Pipe Connection to Cistern***

The flush pipe shall be securely connected to cistern outlet and made airtight by means of a coupling nut. The nuts made of injection-molded HDPE/Polyacetal may be used only if the

end pipe is also made of plastic. The nominal internal diameter of the cistern outlet shall be not less than 32 mm and 38 mm for high-level and low-level cisterns respectively. The screw threads for connection to the flush pipe shall not be less than size 1½ of IS 2643 (Part 3). In the case of polyethylene and unplasticised PVC flush pipes, the upper end of the flush pipe shall be provided with suitable means of ensuring and maintaining a watertight and airtight joint to the flushing cistern. When ordered for use with a flush pipe, the outlet connection may be supplied with coupling nut made of copper based alloy or other non-corrodible material and a plain tail piece having a minimum length of 60 mm. The centre of the outlet hole shall be generally central to the length of the cistern. The length of the outlet shall be 37±2 mm in case of interchangeable siphon; however, where integral siphon is provided, the outlet length shall be 20±2 mm.

**Note:** The length of the cistern outlet shall be the dimension from the bottom surface of the cistern to the end of the outlet after the cistern with siphon/stand pipe has been duly fitted with all washers, lock-nuts, etc.

#### ***Inlet and Overflow Holes***

The cistern shall be provided with inlet and overflow holes, situated one at each end, which shall be capable of accommodating overflow pipe of not less than 20 mm nominal bore and a 15 mm size float valve. The holes shall be cleanly moulded or drilled and the adjacent surfaces shall be smooth.

#### ***Float Valve***

The float valve shall be 15 mm nominal size and shall conform to IS 1703 or IS 12234 or IS 13049.

#### ***Operating Mechanism Lever***

The operating mechanism/lever shall not project beyond the side of the cistern for a distance greater than 350 mm measured from the centre of the cistern to the end of the lever arm. The lever arm shall be provided with a suitable hole near the end through which a split ring or S-hook can be inserted. A string (chain) shall be attached to the ring or hook. When S-hook is employed, it shall be effectively closed after assembly to prevent accidental disconnection. In the case of low-level cisterns, where the mechanism is handle operated, the handle, whether situated on the front or at the end of the cistern, shall be within the projection limit. Particular attention shall be given to the case of operation of the handle.

#### ***String (Chain)***

The string (chain) shall be of such strength as to sustain a dead load of 500 N without any apparent or permanent deformation.

The string (chain) shall terminate in a suitable handle or pull made of a moulding in any heatresisting and non-absorbent plastic or any other equally suitable material. The finish shall be smooth and all burrs which are liable to cause injury to the hand when gripped shall be removed.

#### ***Overflow Pipe***

The overflow pipe shall be of not less than 20 mm nominal bore and shall incorporate a noncorrodible mosquito-proof device secured in a manner which will permit it to be readily cleaned or renewed when necessary. No provision shall be made whereby the overflow from the cistern shall discharge directly into the water-closet or soil pipe without being detected. The invert of the overflow pipe in the case of high-level and low level cisterns and the top edge of the overflow pipe in the case of coupled cistern shall be 19 mm (Min) above the working water level. In case of overflow due to any reason, water should drain out through the overflow pipe and not through the siphon pipe.

#### ***Finish***

The surface of the cistern including cover shall be free from blisters and delamination, and reasonably free from flow lines, streaking or colour variations. The cistern and cover shall be opaque to light.

#### ***Operational and Performance Requirements***

##### ***Flushing Arrangement***

The cistern under working conditions and with the float valve in closed position shall operate on a single operation of the operating mechanism/lever without calling for a sudden jerk in pulling. If a valve is used instead of siphon for flushing purposes, the valve shall be completely leak proof.

#### *Working Water Level*

The working water-level shall be a minimum of 6.5 cm. below the effective top edge of the cistern and shall be legibly and permanently marked on the inside of the cistern. Effective top edge shall be taken on edge after top of the body without considering bead.

#### *Freedom from Self Siphonage*

The siphonic system shall be capable of being rapidly brought into action when the water is at the working water level, but shall not self siphon or leak into the flush pipe when the water is up to 1 cm above the invert of the overflow pipe.

#### *Reduced Water Level*

The discharge shall operate satisfactorily when the cistern is filled to a level up to 1 cm. below the working water level.

#### *Discharge Capacity*

When tested in accordance with IS 7231, cistern of 5 litres and 10 litres capacities, when required to give a full flush, shall respectively discharge 5 litres and 10 litres with variation of  $\pm 0.5$  litres. Dual-flush cistern of 10 litres capacity shall discharge alternatively a short flush of  $5 \pm 0.5$  litres. Dual flush cistern of 6/3 litres capacity shall discharge  $6 \pm 0.5$  litres and alternatively a half flush of  $3 \pm 0.5$  litres.

#### *Discharge Rate*

When tested in accordance with IS 7231, the discharge rate shall be  $10 \pm 0.5$  litres within 6 seconds and  $5 \pm 0.5$  litres within 3 seconds for cistern of capacities 10 litres and 5 litres and  $6 \pm 0.5$  litres within 6 second and  $3 \pm 0.5$  litres within 3 second for cistern of 6/3 litres capacity respectively. The cistern shall be so designed that there is no appreciable variation in the force of the flush during the discharge of the required quantity of water. For coupled cisterns, this test shall not be applicable.

#### ***Special Requirements***

##### *Distortion Resistance Test*

The cisterns, complete with its fittings, shall be installed and filled with water to the marked water line and observed for any distortion. The cistern shall not budge more than 6 mm and the cover shall not be dislodged.

##### *Dead Load Test*

When the flushing mechanism incorporates chain pull or hand operated lever, the cistern, complete with its fittings, when installed and filled with water to the marked water line and tested by the application of a dead load of 230 N applied 6 mm from the end of the operating lever arm for 30 seconds, shall not distort to such an extent that any part becomes detached. In the case of other operating mechanism, the dead load applied shall be a mass equivalent to the operating force required to overcome the normal hydrostatic head; Thirty seconds after the load is removed, the function and appearance of the cistern shall not be impaired.

##### *Front Thrust Test*

The front thrust test shall be applied only to cisterns intended for low level use. The cistern complete with its fittings, when installed and filled with water to the marked water line and tested by the method described in IS 7231, shall not distort to such an extent as to be inoperable or unsightly when the load is removed.

##### *Impact Test*

The cistern, complete with its fittings, when installed and filled as described in IS 7231 shall show no defect after one impact. Repeat the test but with the cistern empty. The cistern shall show no defect after the further impact.

#### **17.1.2 Draining Board**

Draining board made of Glazed fireclay conforming to C.P.W.D. Specifications and as per directions of Engineer-in-Charge, shall be provided. The size of the board shall be as specified. The entire surface including bottom of the board shall be finished smooth.

#### 17.1.3 Foot Rests (Fig. 17.4)

Foot rests shall be of Vitreous China conforming to IS 2556 (Part-X). Foot rests which are rectangular shall meet the minimum requirements and dimensions shown in Fig. 4 and may be of different designs where so specified. Foot rests of different shapes and sizes shall also be allowed subject to approval of Engineer-in-Charge.

#### 17.1.4 Glass Shelf/PVC Shelf

Glass shelf shall consist of an assembly of glass shelf, with anodised aluminium angle frame to support the glass shelf. The shelf shall be of glass of best quality with edges rounded off, and shall be free from flaws specks or bubbles. The size of the shelf shall be 60 x 12 cm unless otherwise specified and thickness not less than 5.5 mm. The shelf shall have C.P. brass brackets which shall be fixed with C.P. brass screws to rawl plugs firmly embedded in the walls. PVC shelf as per manufacturer's specifications and size as specified shall be provided.

#### 17.1.5 Mirror

The mirror shall be of superior glass with edges rounded off or beveled, as specified. It shall be free from flaws, specks or bubbles. The size of the mirror shall be 60 x 45 cm unless specified otherwise and its thickness shall not be less than 5.5 mm. It shall be uniformly silver plated at the back and shall be free from silvering defects. Silvering shall have a protective uniform covering of red lead paint. Where beveled edge mirrors of 5.5 mm thickness are not available, fancy looking mirrors with beading/border or aluminium beading or stainless steel beading/border based on manufacture's specifications be provided nothing extra shall be paid on this account. Backing of mirrors shall be provided with environmentally friendly material other than asbestos cement sheet.

#### 17.1.6 M.S. Stays and Clamps (Fig. 17.5)

The clamps shall be made from 1.5 mm thick M.S. flat of 32 mm width, bent to the required shape and size to fit tightly on the socket, when tightened with nuts & bolts. It shall be formed of two semicircular pieces with flanged ends on both sides with holes to fit in the screws, bolts and nuts 40 mm long. The stay shall be minimum one metre long of 10 mm dia M.S. bar. One end of the stay shall be bent for embedding in the wall in cement concrete block of size 20 x 10 x 10 cm in 1:2:4 mix (1 cement : 2 coarse sand : 4 graded stone aggregate 20 mm nominal size). The concrete shall be finished to match with the surrounding surface.

#### 17.1.7 Pillar Taps

Pillar taps shall be chromium plated brass and shall conform to IS 1795. The nominal sizes of the pillar tap shall be 15 mm or 20 mm as specified. The nominal size shall be designated by the nominal bore of the pipe outlet to which the tap is to be fitted. Finished weights of 15 mm and 20 mm pillar taps shall be as prescribed in Table 17.2.

**TABLE 17.2**  
**Minimum Finished Weights of Pillar Taps**

Particulars	Weights in gms	
	15 mm size	20 mm size
Body	255	505
Washer plate loose valve	15	28
Back nut	40	50
Tap	650	1175

Casting shall be sound and free from laps, blow hole and pitting. External and internal surfaces shall be clean, smooth and free from sand and be neatly dressed. The body, bonnet and other parts shall be machined true so that when assembled, the parts shall be axial, parallel and cylindrical with surfaces smoothly finished.

The area of waterway through the body shall not be less than the area of the circle of diameter equal to the bore of the seating of the tap. The seating of pillar tap shall be integral with the body and edges rounded to avoid cutting of washer. Pillar taps shall be nickel chromium plated and thickness of coating shall not be less than service grade No. 2 of IS 4827 and plating shall be capable of taking high polish which shall not easily tarnish or scale.

Every pillar tap, complete with its component parts shall withstand an internally applied hydraulic pressure of 20 Kg/sq. cm maintained for a period of 2 minutes during which period it shall neither leak nor sweat.

#### **17.1.9 Plastic Seat and Covers for Water Closet (Fig. 17.6)**

The seat and cover shall be of thermosetting or thermoplastic conforming to IS 2548 as specified. Unless otherwise specified these shall be of closed pattern.

**17.1.9.1** Thermosetting plastic used shall conform to grade 2 or 3 of IS 1300 when it is phenolic plastic or IS 3389 when of urea formaldehyde. Thermo plastic materials used may be of Polystyrene conforming to type 2 or 3 of IS 2267 or of polypropylene, Appendix A of IS 2548. In public buildings where rough and heavy use of seats and covers are common, plastic seats shall be moulded out of thermosetting materials, phenolic or urea formaldehyde only and the under side of the seat shall be flat with solid moulding.

**17.1.9.2** The hinging device shall be bronze or brass with nickel chromium plating conforming to IS 1068 and the seat shall have not less than three rubber or plastic buffers of size 25 mm x 40 mm x 10 mm for closed front seats and not less than four for open front seats, which shall be securely fixed to the under side of the seat unless otherwise specified. The cover shall be fitted with the same number of buffers as provided for the seat.

**17.1.9.3** Seats shall have a smooth finish and shall be non absorptive and free from cracks and crevices. They shall be capable of being easily cleaned and shall not be adversely affected by common solvents or household cleanser.

**17.1.9.4 Strength:** The seats shall withstand without permanent distortion of the seat or hinge fittings or damage to any finish, a load of 1150 N for 30 minutes applied in the manner prescribed in IS 2548.

#### **17.1.10 Sinks (Fig. 17.7)**

Laboratory sinks and Kitchen sinks shall be of white glazed fire clay conforming to IS 771 (Part-2) with up to date amendments. The kitchen sink shall be of one piece construction with or without rim but without overflow.

**17.1.10.1** Stainless steel kitchen sink shall be of sizes as specified and shall be conforming to IS 13983 (Fig. 17.7).

#### **17.1.11 Towel Rail**

The towel rail shall be of PTMT as specified and as per direction of Engineer-in-charge.

#### **17.1.12 Toilet Paper Holder**

The toilet paper holder shall be of CP brass or vitreous china as specified and of size and design as approved by the Engineer-in-Charge. It shall be fixed in position by means of C.P. brass screws and rawl plugs embedded in the wall.

#### **17.1.13 Urinals**

**17.1.13.2 Half Stall Urinals (Fig. 17.11) :** They shall be of white vitreous China conforming to IS 2556 (Part 6). They shall be of one piece construction with or without an integral flushing box rim and provided with slots or alternative fixing arrangement at the flat back end. They shall be provided with ridges where integral flushing rim is not provided in the sides of the interior of the bowl, to divert the water towards the front line of the urinal where integral flushing box rim is specified, water spreaders provided shall conform to IS 2556 Part-6 (Fig. 17.13). These shall be vitreous China of one piece construction with

integral flush inlet. The tolerance of  $\pm 4$  per cent may be allowed on the dimensions specified.

**17.1.13.3 Urinal Partition Slabs :** Urinal Partition slabs shall be provided, as specified in the item of work.

**17.1.14 Wash Basins (Fig. 17.14, 17.15, 17.16, 17.17 & 17.18)**

Wash basins shall be of white vitreous china conforming to IS 2556 (Part-I) and IS 2556 (Part-4). Wash basins either of flat back or angle back as specified shall be of one piece construction, including a combined overflow. All internal angles shall be designed so as to facilitate cleaning. Each basin shall have a rim on all sides, except sides in contact with the walls and shall have a skirting at the back. Basins shall be provided with single or double tap holes as specified. The tap holes shall be 28 mm square or 30 mm round or 25 mm round for pop up hole. A suitable tap hole button shall be supplied if one tap hole is not required in installation. Each basin shall have circular waste hole to which the interior of basin shall drain. The waste hole shall be either rebated or beveled internally with dia meter of 65 mm at top. Each basin shall be provided with a non-ferrous 32 mm waste fitting. Stud slots to receive the brackets on the underside of the wash basin shall be suitable for a bracket with stud not exceeding 13 mm diameter, 5 mm high and 305 mm from the back of basin to the centre of the stud. The stud slots shall be of depth sufficient to take 5 mm stud. Every basin shall have an integral soap holder recess or recesses, which shall fully drain into the bowl. A slot type of overflow having an area of not less than 5 sq. cm, shall be provided and shall be so designed as to facilitate cleaning of the overflow. Where oval shape or round shape wash basins are required to be fixed these shall be fixed preferably in RCC platform with local available stone topping either fully sunk in stone top or top flush with the stone topping as directed by Engineer-in-Charge.

The wash basins shall be one of the following patterns and sizes as specified (Fig. 17.14).

(a) Flat back: 660 x 460 mm (Surgeon's Basin)

630 x 450 mm

550 x 400 mm

450 x 300 mm

(b) Angle back: 600 x 480 mm

400 x 400 mm

White glazed pedestals for wash basins, where specified shall be provided. The quality of the glazing of the pedestal shall be exactly the same as that of the basin along with which it is to be installed. It shall be completely recessed at the back to accommodate supply and waste pipes and fittings. It shall be capable of supporting the basin rigidly and adequately and shall be so designed as to make the height from the floor to top of the rim of basin 75 to 80 cm as shown in Fig. 17.14, 17.15, 17.16, 17.17 & 17.18. All the waste fittings shall be brass chromium plated, or as specified.

**17.1.15 Waste Fittings for Wash Basins and Sinks (Fig. 17.8)**

The waste fittings shall be of nickel chromium plated brass, with thickness of plating not less than service grade 2 of IS 4827 which is capable of receiving polish and will not easily scale off. The fitting shall conform in all respect to IS 2963 and shall be sound, free from laps, blow holes and fittings and other manufacturing defects. External and internal surfaces shall be clean and smooth. They shall be neatly dressed and be truly machined so that the nut smoothly moves on the body. Waste fitting for wash basins shall be of nominal size of 32 mm. Waste fittings for sinks shall be of nominal size 50 mm.

**17.1.16 Water Closet (Fig. 17.19, 17.20, 17.21, 17.22 & 17.23)**

**17.1.16.1 Squatting Pans (Indian Type W.C.) (Fig. 17.19, 17.20 & 17.21) :** Squatting pans shall be of white vitreous china conforming to IS 2556 Part-I for General Requirements and relevant IS codes for each pattern as described below:

(i) Long pattern-conforming to IS 2556 (Part-3).

(ii) Orissa pattern-conforming to IS 2556 (Part-3).

(iii) Integrated type conforming to IS 2556 (Part-14).

Preferably Orissa type pan should be used.

Each pan shall have an integral flushing rim of suitable type. It shall also have an inlet or supply horn for connecting the flush pipes, as shown in Fig. 17.19, 17.20 & 17.21. The flushing rim and inlet shall be of the self draining type. It shall have weep hole at the flushing inlet to the pan. The flushing inlet shall be in the front, unless otherwise specified or ordered by the Engineer-in-Charge. The inside of the bottom of the pan shall have sufficient slope from the front towards the outlet and the surface shall be uniform and smooth to enable easy and quick disposal while flushing. The exterior surface of the outlet below the flange shall be an unglazed surface which shall have grooves at right angles to the axis of the outlet. In all cases a pan shall be provided with a (100 mm) S.C.I. trap 'P' or 'S' type with approximately 50 mm water seal and 50 mm dia vent horn, where required by the Engineer-in-Charge.

**17.1.16.2 Wash Down Type (European Type W.C.) (Fig. 17.22 & 17.23) :** Water closets shall be of white vitreous china conforming to IS 2556 (Part-1) and 2556 (Part-2), as specified and shall be of "Wash down type". The closets shall be either of the two patterns (Pattern I & Pattern II) and sizes as shown in Fig. 17.22 & 17.23 as specified. The closets shall be of one piece construction. Each water closet shall have not less than two holes having a minimum diameter of 6.5 mm for fixing to floor and shall have an integral flushing rim of suitable type. It shall also have an inlet or supply horn for connecting the flushing pipe of dimensions as shown in table in Fig. 17.20 & 17.21 the flushing rim may be boxed or open type. In the case of box rims adequate number of holes, on each side together with a slot opposite the inlet shall be provided. The flushing rim and inlet shall be of the self draining type. The water closet shall have a weep hole at the flushing inlet. Each water closet shall have an integral trap with either 'S' or 'P' outlet with at least 50 mm water seal. For P trap, the slope of the outlet shall be 14 deg. below the horizontal. Where required the water closet shall have an antisiphonage 50 mm dia vent horn on the outlet side of the trap with dimension conforming to those given in Fig. 17.22 and on either right or left hand or centre as specified set at an angle of 45 deg. and invert of vent hole not below the central line of the outlet. The inside surface of water closets and traps shall be uniform and smooth in order to enable an efficient flush. The serrated part of the outlet shall not be glazed externally. The water closet, when sealed at the bottom of the trap in line with the back plate, shall be capable of holding not less than 15 litres of water between the normal water level and the highest possible water level of the water closet as installed.

## **17.2 GENERAL REQUIREMENTS FOR INSTALLATION OF W.C. PAN**

**17.2.1** The work shall be carried out, complying in all respects with the requirements of relevant byelaws of the local body in whose jurisdiction the work is situated.

**17.2.2** Any damage caused to the building, or to electric, sanitary, water supply or other, installations etc. therein, either due to negligence on the part of the contractor, or due to actual requirements of the work, shall be made good and the building or the installation shall be restored to its original condition by the contractor. Nothing extra shall be paid for such restoration works except where otherwise specified.

**17.2.3** For making good the damage to the under mentioned items of work, the specifications as given in the following paras shall apply, unless directed otherwise.

(a) **Masonry Work:** The masonry work shall be made good by using the same class of bricks, tiles or stones as was damaged during the execution of the work. The mortar used shall be cement mortar 1:5 (1 cement: 5 fine sand) or as directed by the Engineer-in-Charge.

(b) **Plain Concrete Work :** Concrete work for sub-grade of the flooring, foundations and other plain concrete works shall be cement concrete 1:5:10 (1 cement : 5 coarse sand : 10 graded stone aggregate 40 mm nominal size). A coat of neat cement slurry shall be applied at the junction with old work, before laying fresh concrete.

(c) **Cement Concrete Flooring and R.C.C. Work :** Cement concrete 1:2:4 (1 Cement : 2 Coarse sand : 4 graded stone aggregate 20 mm nominal size) shall be used after applying a coat of neat cement slurry at the junction with old work, and the surface finished to match with the surrounding surface.



(d) **Plastering:** Cement plaster 1:4 (1 cement: 4 sand) shall be used. The sand shall be fine or coarse, as used in the original work. The surface shall be finished with two or more coats of white wash, colour wash, distemper or painting as required, but where the surface is not to be white washed, colour washed, distempred or painted, it shall be finished as required to match with the surrounding surface.

(e) **Other Items:** Damage to any other item shall be made good as directed by the Engineer-in-Charge.

**Note:** In all the above operations the damaged portion shall be cut in regular geometric shape and cleaned before making good the same.

**17.2.4** All exposed G.I., C.I. or lead pipes and fittings shall be painted with approved quality of paint and shade as specified. The painting work shall conform to specification described under SH: Painting.

**17.2.5** All sanitary and plumbing work shall be carried out through licensed plumbers.

**17.2.6** On completion of the work the site shall be cleaned and all rubbish disposed off as directed by the Engineer-in-Charge.

**17.2.7** Various sanitary fittings described under 17.1 including fixing shall be enumerated individually or in combination under relevant items of works as described below. When used in combination, specifications as described under relevant paras shall apply but nothing extra shall be paid for making connections required for successful functioning of the combination.

## **17.4 INSTALLATIONS OF FLUSHING CISTERN**

### **17.4.1 Fixing**

**17.4.1.1 Low Level Cistern:** The cistern shall be fixed on C.I. cantilever brackets which shall be firmly embedded in the wall in cement concrete (1:2:4) block 100 x 75 x 150 mm. Connection between cistern and closet shall be made by means of 40 mm dia flush bend with rubber or G.I. inlet connection as specified.

**17.4.1.2 Automatic Cistern:** Clause 17.4.1.1 shall apply except that CP Brass stop cock shall be provided for cistern having a capacity of more than 5 liter. The main & distribution flush pipe shall be fixed to the wall by means of standard pattern holder bat clamp shown in Fig. 17.5.

### **17.4.2 Painting**

The brackets shall be painted, if specified, with two or more coats of paint of approved shade and quality.

### **17.4.3 Measurements**

Cistern, including all fittings, shall be measured in numbers.

### **17.4.4 Rate**

The rate shall include the cost of all materials and labour involved in all the operations described above.

## **17.5 INSTALLATION OF MIRROR**

### **17.5.1 Fixing**

The mirror shall be mounted on backing with environmentally friendly material other than asbestos cement sheet shall be fixed in position by means of 4 C.P. brass screws and C.P. brass washers, over rubber washers and wooden plugs firmly embedded in walls. C.P. brass clamps with C.P. brass screws may be an alternative method of fixing, where so directed. Unless specified otherwise the longer side shall be fixed horizontally.

### **17.5.2 Measurements**

Mirror shall be measured in numbers.

### **17.5.3 Rate**

Rate shall include the cost of all the materials and labour involved in all the operations described above.

## **17.7 INSTALLATION OF SEAT AND COVER TO WATER CLOSET**

### **17.7.1 Fixing**

The seat shall be fixed to the pan by means of two corrosion resistant hinge bolts with a minimum length of shank of 65 mm and threaded to within 25 mm of the flange supplied by the manufacturer along with the seat. Each bolt shall be provided with two suitably shaped washers of rubber or other similar materials for adjusting the level of the seat while fixing it to the pans. In addition, one non-ferrous or stainless steel washer shall be provided with each bolt. The maximum external diameter of the washer fixed on the underside of the pan shall not be greater than 25 mm. Alternative hinging devices as supplied by the manufacturer of the seat can also be used for fixing with the approval of Engineer-in-Charge.

### 17.7.2 Measurements

Seat with cover shall be measured in numbers.

### 17.7.3 Rate

Rate shall include the cost of all the materials and labour involved in all the operations described above.

## 17.8 INSTALLATION OF SINK

**17.8.0** The installation shall consist of assembly of sink C.I. brackets, union and G.I. or P.V.C. waste pipe.

### 17.8.1 Fixing

The sink shall be supported on C.I. cantilever brackets, embedded in cement concrete (1:2:4) block of size 100 x 75 x 150 mm. Brackets shall be fixed in position before the dado work is done. The C.P. brass or P.V.C. union shall be connected to 40 mm nominal bore G.I. or PVC waste pipe which shall be suitably bent towards the wall and shall discharge into a floor trap. C.P. brass trap and union and waste shall be paid separately. The height of front edge of sink from the floor level shall be 80 cm.

### 17.8.2 Measurements

The sinks shall be measured in numbers.

### 17.8.3 Rate

Rate shall include the cost of all materials and labour involved in all the operations described above but shall not included the cost of waste fitting and brackets which shall be paid for separately.

## 17.9 INSTALLATION OF URINAL LIPPED, HALF STALL (SINGLE OR RANGE) (FIG. 17.9 & 17.11)

**17.9.0** Urinal installation shall consist of a lipped urinal (Single or range), an automatic flushing cistern, G.I. flush and waste pipe. The capacity of flushing cistern and relevant size of flush pipe for urinals in a range shall be as prescribed in Table 17.3. Waste pipe shall be of 32 mm nominal bore G.I. pipe and shall be paid separately.

### 17.9.1 Fixing

Urinals shall be fixed in position by using wooden plugs and screws. It shall be at a height of 65 cm from the standing level to the top of the lip of the urinal, unless otherwise directed by the Engineer-in- Charge. The size of wooden plugs shall be 50 mm × 50 mm at base tapering to 38 mm × 38 mm at top and of length 5.0 cms. These shall be fixed in the wall in cement mortar 1:3 (1 cement: 3 fine sand). After the plug fixed in the wall, the mortar shall be cured till it is set.

**TABLE 17.3**

<i>No. of Urinals in range</i>	<i>Capacity of Flushing Cistern</i>	<i>Size of Flush Pipe (Galvanised Iron)</i>	
		<i>Main</i>	<i>Distribution</i>
One	5 Litres	15 mm	15 mm
Two	10 Litres	20 mm	15 mm
Three	10 Litres	25 mm	15 mm
Four	15 Litres	25 mm	15 mm

Each urinal shall be connected to 32 mm dia waste pipe which shall discharge into the channel or a floor trap. The connection between the urinal and flush or waste pipe shall be made by means of putty or white lead mixed with chopped hemp.

### 17.9.2 Measurements

Urinals shall be measured in numbers.

**17.9.3 Rate**

Rate shall include the cost of all the materials and labour involved in all the operations described above.

**17.10 INSTALLATION OF STALL URINAL (SINGLE OR RANGE)**

**17.10.0** The installation shall consist of stall urinal (single or range), automatic flushing cistern, C.P. brass standard flush pipes, C.P. brass spreader and C.I. trap with tail piece and outlet grating of C.P. brass. Capacity of flushing cistern and relevant size of flush pipe, C.I. trap shall be as prescribed in Table 17.4.

**TABLE 17.4**

No. of Urinals in range	Capacity of Flushing cistern	Size of Flush Pipe (Chromium Plated)		Diameter of C.I. Traps
		Main	Distribution	
One	05 Litres	15 mm	15 mm	50 mm
Two	10 Liters	20 mm	15 mm	50 mm
Three	15 Litres	25 mm	15 mm	80 mm
Four	15 Litres	25 mm	15 mm	80 mm

**17.10.1 Fixing**

The floor slab shall be suitably sunk to receive the stall urinal. Where the floor slab is not sunk, the stall urinal shall be provided over a platform. The lip of the stall urinal shall be flush with the finished floor level adjacent to it. The stall urinal shall be laid over a fine sand cushion of average 25 mm thickness. A space of not less than 3 mm shall be provided all-round, in front, sides and filled with water proofing plastic compound. Care shall be taken that after the sub-grade for the floor is cast, one week should lapse before urinals are installed. The trap and fittings shall be fixed as directed by the Engineerin- Charge. Payment for the floor and its sub-grade shall be made separately.

**17.10.2 Measurements**

Stall urinals shall be measured in numbers.

**17.10.3 Rate**

The rate shall include the cost of all the materials and labour involved in all the operations described above.

**17.11 INSTALLATION OF WASH BASIN (FIG. 17.14, 17.15, 17.16, 17.17 & 17.18)**

**17.11.0** The installation shall consist of an assembly of wash basin, pillar taps, C.I. brackets, C.P. brass or P.V.C. union, as specified. The wash basin shall be provided with one or two 15 mm C.P. brass pillar taps, as specified. The height of top of the rim of wash basin from the floor level shall be within 750 mm to 800 mm.

**17.11.1 Fixing**

The basin shall be supported on a pair of C.I. cantilever brackets conforming to IS 775 and be embedded in cement concrete (1:2:4) block 100 x 75 x 150 mm. Use of M.S. angle or Tee section as bracket is not permitted. Brackets shall be fixed in position before dado work is done. The brackets have been shown in Fig. 17.15. The wall plaster on the rear shall be cut to rest over the top edge of the basin so as not to leave any gap for water to seep through between wall plaster & skirting of basin. After fixing the basin, plaster shall be made good and surface finished matching with the existing one. S.C.I. floor traps conforming to IS 1729 having 50 mm water seal (minimum 35 mm in two pipe systems with gully trap) should be used. Waste pipes laid horizontally should have gradient not flatter than 1 in 50 and not steeper than 1 in 10. The waste water from wash basin shall be discharged directly to vitreous semi-circular open drain, discharging to a floor trap and finally to the vertical stack (Fig.17.15) on upper floors and in case of ground floor, the waste water shall be discharged either directly to the gully trap or through the floor trap (Fig. 17.16). C.P. brass trap and union are not to be used in such situations.

If waste pipe is concealed or crosses the wall, waste water shall be discharged through non ferrous trap like PVC Engineering plastic or C.P. brass and union (Fig. 17.17) to vertical stack. The C.P. brass trap and union shall be paid for separately. Where so specified a 20

mm G.I. puff pipe terminating with a perforated brass cap screwed on it on the outside of the wall or connected to the antisiphon stack shall be provided.

**17.11.2 Measurements**

Wash basins shall be measured in numbers.

**17.11.3 Rate**

The rate shall include the cost of all the materials and labour involved in all the operations described above.

**17.13 INSTALLATION OF WATER CLOSET**

**17.13.0** Installation shall consist of water closet with seat and cover, flushing cistern and flush bend.

**17.13.1 Fixing**

The closet shall be fixed to the floor by means of 75 mm long 6.5 mm diameter counter-sunk bolts and nuts embedded in floor concrete.

**17.13.2 Measurements**

Water closets shall be measured in numbers.

**17.13.3 Rate**

Rate shall include the cost of all the materials and labour involved in all the operations described above.

**17.16 INSTALLATION OF TOWEL RAIL**

It shall be fixed in position by means of C.P. brass screws on wall surface by PVC dash fasteners, firmly embedded in wall.

**17.16.1 Measurements**

Towel rails shall be measured in numbers.

**17.16.2 Rate**

Rate shall include the cost of all the materials and labour involved in all the operations described above.

**Note:- For further detail refer CPWD specification volume 2, Sub Head 17.0**

## SUB HEAD : 18.0 WATER SUPPLY

### 18.1 TERMINOLOGY

**Air Gap:** The unobstructed vertical distance through the free atmosphere between the lowest opening from any pipe or fitting supplying water to a tank or other device and the flood level rim of the receptacle in a water supply system.

**Air Valve:** A valve that releases air from a pipe line automatically without loss of water, or introduces air into a pipe line automatically if the internal pressure becomes less than that of the atmosphere.

**Available Head:** The head of water available at the point of consideration due to main's pressure or overhead tank or any other source of pressure.

**Back Flow:** The flow of water into the distributing pipes of water system from any source or sources other than its intended source.

**Back Siphonage:** The flowing back of used, contaminated or polluted water from a plumbing fitting or vessel into a water supply system due to a lowering of pressure in such system.

**Ball Cock (Fig. 18.1):** A faucet opened or closed by the fall or rise of a ball floating on the surface of water.

**Branch (Fig. 18.2):** (i) A special form of cast iron pipe used for making connections to water mains. The various types are called T, Y, T-Y, double Y, and V branches, according to their respective shapes.

(ii) Any part of a piping system other than a main.

**Capacity:** The storage capacity of storage or flushing cistern or a tank when filled up to the water line.

**Non Return Valve (Fig. 18.4):** A device provided with a disc hinged on one edge so that it opens in the direction of normal flow and closes with reversal of flow.

**Collar:** A pipe fitting in the form of a sleeve for jointing the spigot ends of two pipes in the same alignment.

**Coupling:** A pipe fitting with inside threads only, used for connecting two pieces of pipe.

**Cross (Fig. 18.2):** A pipe fitting used for connecting four pipes at right angles.

**Elbow (Fig. 18.2):** A pipe fitting for providing a sharp change of direction in a pipe line.

**Ferrule (Fig. 18.2):** A pipe fitting for connecting a service pipe to a water main.

**Fitting:** Anything fitted or fixed in connection with the supply, measurement, control, distribution, utilization or disposal of water.

**Fire Hydrant (Fig. 18.5):** A device connected to a water main and provided with necessary valve and outlets, to which a fire hose may be attached for discharging water at a high rate for the purpose of extinguishing fires, washing down streets, or flushing out the water main.

**Flange (Fig. 18.2):** A projecting flat rim on the end of a valve, pipe etc.

**Flanged Pipe (Fig. 18.2):** A pipe provided with flanges so that the ends can be joined together by means of bolts.

**Float Valve:** A valve in which the closure to an opening such as a plug or gate is actuated by a float to control the flow into a tank.

**Sluice Valve (Gate Valve) (Fig. 18.4) :** A valve in which the flow of water is cut off by means of a circular disc., fitting against machine-smoothed faces, at right angles to the direction of flow. The disc is raised or lowered by means of a threaded stem connected to the handle of the valve; the opening in the valve is usually as large as the full bore of the pipe.

**Nipple (Fig. 18.2):** A tubular pipe fitting usually threaded on both ends and less than 300 mm long used for connecting pipes or fittings.

**Offset:** A combination of elbows or bends which brings one section of the pipe out of line but into a line parallel with the other section in a piping system.

**Reflux Valve (Fig. 18.4):** A non return valve used in a pipe line at a rising gradient to prevent water that is ascending the gradient from flowing back in the event of a burst lower down.

**Socket (Fig. 18.2):** The female part of the spigot and socket joint.

**Spigot (Fig. 18.2):** The male part of a spigot and socket joint.

**Stop Cock (Fig. 18.3):** A control valve fixed at the end of a communication pipe which controls the supply from the water main.

**Storage Tank:** A tank or a cistern for storage of water which is connected to the water main by means of a supply pipe.

**Service or Supply Pipe:** Pipe through which supply is drawn from water mains.

**Union (Fig. 18.2):** A pipe fitting used for joining the ends of two pipes neither of which can be turned.

**Valve:** A device used for controlling the flow of water in a pipe line.

## **18.2 GENERAL REQUIREMENTS**

**18.2.1** Any damage caused to the building, or to electric, sanitary water supply or other installations etc. therein either due to negligence on the part of the contractor, or due to actual requirements of the work, shall be made good and the building or the installations shall be restored to its original condition by the contractor. Nothing extra shall be paid for it, except where otherwise specified.

**18.2.2** All water supply installation work shall be carried out through licensed plumbers.

**18.2.3** It is most important to ensure that wholesome water supply provided for drinking and culinary purposes, is in no way liable to contamination from any less satisfactory water. There shall, therefore, be no cross connection whatsoever between a pipe or fitting for conveying or containing wholesome water and a pipe or fitting for conveying or containing impure water or water liable to contamination or of uncertain quality of water which has been used for any purpose. The provision of reflux or non-return valves or closed and sealed valves shall not be construed a permissible substitute for complete absence of cross-connection.

**18.2.4** Where a supply of wholesome water is required as an alternative or standby to supply of less satisfactory water or is required to be mixed with the latter, it shall be delivered only into a cistern, and by a pipe or fitting discharging into the air gap at a height above the top edge of the cistern equal to twice its nominal bore, and in no case less than 15 cm.

**18.2.5** No piping shall be laid or fixed so as to pass into, through or adjoining any sewer, scour outlet or drain or any manhole connected therewith nor through any ash pit or manure-pit or any material of such nature that can cause undue deterioration of the pipe.

**18.2.6** Where the laying of any pipe through fouled soil or previous material is unavoidable, the piping shall be properly protected from contact with such soil or material by being carried through an exterior cast iron tube or by some other suitable means. Any piping or fitting laid or fixed which does not comply with the above requirements, shall be removed and re-laid in conformity with the above requirements.

**18.2.7** The design of the pipe work shall be such that there is no possibility of backflow towards the source of supply from any cistern or appliance whether by siphonage or otherwise, and reflux or nonreturn valves shall not be relied upon to prevent such back flow.

**18.2.8** All pipe work shall be so designed, laid or fixed, and maintained so that it remains completely watertight, thereby avoiding wastage of water, damage to property and the risk of contamination of the water conveyed.

**18.2.9** In designing and planning the layout of the pipe work, due attention shall be given to the maximum rate of discharge, required economy in labour and materials, protection against damage and corrosion, protection from frost, if required, and to avoidance of airlocks, noise transmission and unsightly arrangement.

**18.2.10** To reduce frictional losses, piping shall be as smooth as possible inside. Methods of jointing shall be such as to avoid internal roughness and projection at the joints, whether of the jointing materials or otherwise.

**18.2.11** Change in diameter and in direction shall preferably be gradual rather than abrupt to avoid undue loss of head. No bend or curve in piping shall be made so as to materially reduce or alter the cross-section.

**18.2.12** Underground piping shall be laid at such a depth that it is unlikely to be damaged by frost or traffic loads and vibrations. It shall not be laid in ground liable to subsidence, but where such ground cannot be avoided; special precautions shall be taken to avoid damage to the piping. Where piping has to be laid across recently disturbed ground, the ground shall be thoroughly consolidated so as to provide a continuous and even support.

**18.2.13** Where the service pipe is of diameter less than 50 mm the stop valves shall be of the screwdown type and shall have loose washer plates to act as non-return valves. Other stop valves in the service line may be of the gate type.

**18.2.14** In flats and tenements supplied by a common service pipe a stop valve shall be fixed to control the each branch separately. In large buildings a sufficient number of stop valves shall be fixed on branch pipes, and to control groups of ball valves and draw off taps, so as to minimize interruption of the supply during repairs, all such stop valves shall be fixed in accessible positions and properly protected from being tampered with, they may be of the gate type to minimize loss of head by friction.

**18.2.15** Water for drinking or for culinary purposes as far as possible shall be on branch pipes connected directly to the service pipe.

**18.2.16** Pumps shall not be allowed on the service pipe as they cause a drop of pressure on the suction side thereby affecting the supply to the adjoining properties. In cases where pumping is required, a properly protected storage tank of adequate capacity shall be provided to feed the pump.

**18.2.17** Service pipes shall be so designed and constructed as to avoid air-locks, so that all piping and fittings above ground can be completely emptied of water to facilitate repairs. There shall be draining taps or draw-off taps (not underground) at the lowest points, from which the piping shall rise continuously to draw-off taps, ball valves, cisterns, or vents (where provided at the high points).

**18.2.18** Service pipes shall be designed so as to reduce the production and transmission of noise as much as possible. Appliances which create noise shall be installed as far distant as possible from the living rooms of the house. High velocity of water in piping and fittings shall be avoided. Piping shall be confined, as far as possible, to rooms where appliances are fixed, it shall have easy bends, and where quietness is particularly desired, holder bats or clamps shall be insulated from the piping by suitable pads.

**18.2.19** The rising pipe to the storage cistern, if any, or to any feed cistern shall be taken as directly as possible to the cistern and shall be fixed away from windows or ventilators.

**18.2.20** All pipe work shall be planned so that the piping is accessible for inspection, replacement and repair. To avoid its being unsightly, it is usually possible to arrange it in or adjacent to cupboards, recesses, etc. provided there is sufficient space to work on the piping with the usual tools. Piping shall not be buried in walls or solid floors. Where unavoidable, piping may be buried for short distances provided that adequate protection is given against damage and that no joints are buried. If piping is laid in ducts or chases, these shall be roomy enough to facilitate repairs and shall be so constructed as to prevent the entry of vermin. To facilitate removal of pipe casing, floor boards covering piping shall be fixed with screws or bolts.

**18.2.21** When it is necessary for a pipe to pass through a wall or floor, a sleeve shall be fixed therein for insertion of the pipe and to allow freedom for expansion, contraction and other movement. Piping laid in wood floors shall, where possible, be parallel with the joists.

**18.2.22** Where storage tanks are provided to meet overall requirements of water connection of service pipe with any distributing pipe shall not be permitted except one direct connection for culinary or drinking requirements.

**18.2.23** No service pipe shall be connected to any water closet or urinal. All such supplies shall be from flushing cisterns which shall have supply from storage tank.

**18.2.24** No service or supply pipe shall be connected directly to any hot-water system or to any apparatus used for heating other than through a feed cistern thereof.

### **18.3 MATERIALS**

**18.3.0** The standard size of brass or gun metal fittings shall be designated by the nominal bore of the pipe outlet to which the fittings are attached. A sample of each kind of fittings shall be got approved from the Engineer-in-Charge and all supplies made according to the approved samples. All cast iron fittings shall be sound and free from laps, blow holes and pitting. Both internal and external surfaces shall be clean, smooth and free from sand etc. Burning, plugging, stopping or patching of the casting shall not be permissible. The bodies, bonnets, spindles and other parts shall be truly machined so that when assembled the parts shall be axial, parallel and cylindrical with surfaces smoothly finished. The area of the water way of the fittings shall not be less than area of the nominal bore, chromium plating wherever specified shall be of 0.3 micron. The chromium shall never be deposited on brass unless a heavy coating of nickel is interposed. In the case of iron a thick coat of copper shall first be applied, then one of nickel and finally the chromium. In finish and appearance the plated articles when inspected shall be free from plating defects such as blisters, pits roughness and unplated areas and shall not be stained or discoloured. Before fitting is plated, the washer plate shall be removed from the fittings, the gland packing shall be protected from the plating solution.

### 18.3.1 Ball Valve (Brass)

The ball valve shall be of Brass or Gunmetal as specified conforming to IS 1703 (Fig. 18.1). The ball valve shall be of following two classes:—

(a) **High Pressure:** High pressure float valves are indicated by the abbreviation ‘HP’ and are designed for use on mains having pressure of 0.175 MPa or above.

(b) **Low Pressure:** Low Pressure float valves are indicated by the abbreviation ‘LP’ and are designed for use on mains having a pressure up to. 0.175 MPa.

The ball valves shall be of following nominal sizes 15 mm, 20 mm, 25 mm, 32 mm, 40 mm and 50 mm. The nominal size shall correspond with the nominal bore of the inlet shanks. Polyethylene floats shall conform to IS 9762.

### 18.3.2 Bib Taps and Stop Valve

Brass (Fig. 18.3): A bib tap is a draw off tap with a horizontal inlet and free outlet and a stop valve is a valve with suitable means of connections for insertion in a pipe line for controlling or stopping the flow. They shall be of specified size and shall be of screw down type and shall conform to IS 781. The closing device shall work by means of disc carrying a renewable non-metallic washer which shuts against water pressure on a seating at right angles to the axis of the threaded spindle which operates it. The handle shall be either crutch or butterfly type securely fixed to the spindle. Valve shall be of the loose leather seated pattern. The cocks (taps) shall open in anti-clock wise direction. The bib tap and stop valve shall be polished bright. The minimum finished weights of bib tap and stop valve shall be as specified in Table 18.1.

**TABLE 18.1**  
**Minimum Finished Mass of Bib Taps and Stop Valves**

Size	Minimum Finished Mass			
	Bib Taps	Stop Valves		
		Internally Threaded	Externally Threaded	Mixed End
(1)	(2)	(3)	(4)	(5)
mm	kg	kg	kg	kg
8	0.250	0.220	0.250	0.235
10	0.300	0.300	0.350	0.325
15	0.400	0.330	0.400	0.365
20	0.750	0.675	0.750	0.710
25	1.250	1.180	1.300	1.250
32	--	1.680	1.800	1.750
40	--	2.090	2.250	2.170
50	--	3.700	3.850	3.750

In case these are required to be nickel plated, the plating shall be of the first quality with a good thick deposit of silvery whiteness capable of taking high polish which will not easily tarnish or scale.



### **18.3.3 Ferrules (Fig. 18.2)**

The ferrules for connection with C.I. main shall generally conform to IS 2692. It shall be of non ferrous materials with a C.I. bell mouth cover and shall be of nominal bore as specified. The ferrule shall be fitted with a screw and plug or valve capable of completely shutting off the water supply to the communication pipe, if and when required.

### **18.3.4 Fire Hydrants (Fig. 18.5)**

The hydrant shall conform to IS 909 and shall consist of the following components:

- (a) Body (d) Gland (g) Valve
- (b) Bonnet (e) Spindle Cap (h) Screwed Outlet
- (c) Spindle (f) Spindle Nut (i) Outlet and Chain

The body, bonnet, gland, outlet cap and spindle cap and shall be of good quality cast iron grade FG 200 of IS 210. Outlet, seat for valve, valve, spindle nut, check nut shall be made of copper alloy as per IS 909.

### **18.3.5 Gate Valve - Gun Metal (Fig. 18.5)**

These shall be of the gun metal fitted with wheel and shall be of gate valve type opening full way and of the size as specified. These shall generally conform to IS 778.

### **18.3.6 Pig Lead**

Pig lead shall be of uniform quality, clean and free from foreign materials. It shall be of uniform softness and capable of being easily caulked or driven. It shall conform to IS 782 for caulking lead in all respects.

### **18.3.7 Lead Wool**

Lead wool shall conform to IS 782 in all respects. Lead wool shall consist of fine strands or plated ribbons of lead. The cross-section of the individual strands shall be flat. The dimensions in the sectional plane shall not be less than 0.13 mm and not more than 0.90 mm and the rope shall be supplied in minimum lengths of two metres and the maximum length in any one package shall be such that the package does not weigh more than 50 Kg.

### **18.3.8 Non-Return Valve (Gun Metal) (Fig. 18.4)**

A non-return valve permits water to flow in one direction only and is provided on the ascending part of the main to check return flow. The non-return valve shall be of Gun metal and shall be of horizontal or vertical flow type as specified. The valve shall be of quality approved by the Engineer-in-Charge and shall generally conform to IS 778.

### **18.3.9 Pipes and Specials**

Pipes and specials may be of any of the following types as specified:

- (a) Cast iron centrifugally cast (spun) – IS 1536
- (b) Galvanised steel – IS 1239 & IS 4736
- (c) PE-AL-PE Pipes – IS 15450
- (d) PP-R Pipes – IS 15801
- (e) CPVC pipes – IS 15778

In choosing the material for piping and fittings, account shall be taken of the character of the water to be conveyed through it, the nature of the ground in which the pipes are to be laid and the relative economics.

### **18.3.11 Pipes-Galvanised Iron**

**18.3.11.1** The pipes (tubes) shall be galvanised mild steel hot finished seamless (HFS) or welded (ERW) HRIW or HFW screwed and socketed conforming to the requirements of IS 1239 Part-I for medium grade. They shall be of the diameter (nominal bore) specified in the

description of the item, the sockets shall be designated by the respective nominal bores of the pipes for which they are intended.

**18.3.11.2 Galvanising shall conform to IS 4736 :** The zinc coating shall be uniform adherent, reasonably smooth and free from such imperfections as flux, ash and dross inclusions, bare patches, black spots, pimples, lumping runs, rust stains, bulky white deposits and blisters. The pipes and sockets shall be cleanly finished, well galvanised in and out and free from cracks, surface flaws laminations and other defects. All screw threads shall be clean and well cut. The ends shall be cut cleanly and square with the axis of the tube.

**18.3.11.3** The dimensions and weights of pipes and sockets and tolerances shall be as prescribed in Appendix 'C'.

**18.3.11.4** All screwed tubes and sockets shall have pipe threads conforming to the requirements of IS 554. Screwed tubes shall have taper threads while the sockets shall have parallel threads.

**18.3.11.5** All tubes shall withstand a test pressure of 50 Kg/sq.cm without showing defects of any kind.

**18.3.11.6 Fittings :** The fittings shall be of mild steel tubular or wrought steel fittings conforming to IS 1239 (Part-2) or as specified. The fittings shall be designated by the respective nominal bores of the pipes for which they are intended.

#### **18.3.12 Shower Rose Brass**

The shower rose shall be of chromium plated brass of specified diameter. It shall have uniform perforations. The inlet size shall be 15 mm or 20 mm as required.

### **18.4 LAYING AND JOINTING OF PIPES AND FITTINGS**

#### **18.4.1 Unloading**

**18.4.1.1** The pipes shall be unloaded where they are required.

**18.4.1.2 Unloading (except where mechanical handling facilities are available) :** Pipes weighing up to 60 kg shall be handled by two persons by hand passing. Heavier pipes shall be unloaded from the lorry or wagon by holding them in loops, formed with ropes and sliding over planks set not steeper than 45 degree. The planks shall be sufficiently rigid and two ropes shall always be used to roll the pipes down the planks. The ropes should be tied on the side opposite the unloading. Only one pipe shall be unloaded at a time.

**18.4.1.3** Under no circumstances shall the pipes be thrown down from the carriers or be dragged or rolled along hard surfaces.

**18.4.1.4** The pipes shall be checked for any visible damage (such as broken edges, cracking or spalling of pipe) while unloading and shall be sorted out for reclamation. Any pipe which shows sufficient damage to preclude it from being used shall be discarded.

#### **18.4.2 Storing**

**18.4.2.1** The pipes and specials shall be handled with sufficient care to avoid damage to them. These shall be lined up on one side of the alignment of the trench, socket facing upgrade when line runs uphill and upstream when line runs on level ground.

**18.4.2.2** Each stack shall contain pipes of same class and size, consignment or batch number and particulars of suppliers, wherever possible, shall be marked on the stack.

**18.4.2.3** Storage shall be done on firm, level and clean ground. Wedges shall be provided at the bottom layer to keep the stack stable.

### **18.4.3 Cutting**

**18.4.3.1** Cutting of pipes may be necessary when pipes are to be laid in lengths shorter than the lengths supplied, such as while replacing accessories like tees, bends, etc. at fixed position in the pipe lines.

**18.4.3.2** A line shall be marked around the pipe with a chalk piece at the point where it is to be cut. The line shall be so marked that the cut is truly at right angle to the longitudinal axis of the pipe. The pipe shall be rigidly held on two parallel rafters nailed to cross beams, taking care that the portion to be cut does not overhang and the cut mark is between the two rafters. The pipe shall be neatly cut at the chalk mark with carpenter's saw or hacksaw having a long blade, by slowly rotating the pipe around its longitudinal axis so as to have the uncut portion on top for cutting. Cutting of the pipe at the overhang should, as far as possible, be avoided, as an overhanging and is liable to tear off due to its weight before the cutting is complete.

### **18.4.4 Trenches**

**18.4.4.1** The trenches shall be so dug that the pipes may be laid to the required alignment and at required depth.

**18.4.4.2** Cover shall be measured from top of pipe to the surface of the ground.

**18.4.4.3** The bed of the trench, if in soft or made up earth, shall be well watered and rammed before laying the pipes and the depressions, if any, shall be properly filled with earth and consolidated in 20 cm layers.

**18.4.4.4** If the trench bottom is extremely hard or rocky or loose stony soil, the trench shall be excavated at least 150 mm below the trench grade. Rocks, stone or other hard substances from the bottom of the trench shall be removed and the trench brought back to the required grade by filling with selected fine earth or sand (or fine moorum if fine soil or sand is not available locally) and compacted so as to provide a smooth bedding for the pipe. Where excavation requires blasting operation, it shall be ensured that no pipes have been stacked in the vicinity and completed pipe line in the vicinity has already been covered before starting of blasting operations; this is necessary to prevent damage to the exposed pipes in the vicinity by falling stones as a result of blasting.

**18.4.4.5** After the excavation of the trench is completed, hollows shall be cut at the required position to receive the socket of the pipes and these hollows shall be of sufficient depth to ensure that the barrels of the pipes shall rest throughout their entire length on the solid ground and that sufficient spaces left for jointing the underside of the pipe joint. These socket holes shall be refilled with sand after jointing the pipe.

**18.4.4.6** Roots of trees within a distance of about 0.5 metre from the side of the pipe line shall be removed or killed.

**18.4.4.7** The excavated materials shall not be placed within 1 metre or half of the depth of the trench, whichever is greater, from the edge of the trench. The materials excavated shall be separated and stacked so that in refilling they may be re-laid and compacted in the same order to the satisfaction of the Engineer-in-Charge.

**18.4.4.8** The trench shall be kept free from water. Shoring and timbering shall be provided wherever required. Excavation below water table shall be done after dewatering the trenches.

**18.4.4.9** Where the pipe line or drain crosses an existing road, the road crossing shall be excavated half at a time, the 2nd half being commenced after the pipes have been laid in the first half and the trench refilled. Necessary safety measures for traffic as directed shall be adopted. All types, water mains cables, etc. met within the course of excavation shall be carefully protected and supported. Care shall be taken not to disturb the electrical and communication cable met with during course of excavation, removal of which, if necessary, shall be arranged by the Engineer-in-Charge.

#### **18.4.5 Laying**

**18.4.5.1** The pipes shall be lowered into the trench by means of suitable pulley blocks, sheer legs chains ropes etc. In no case the pipes shall be rolled and dropped into the trench. One end of each rope may be tied to a wooden or steel peg driven into the ground and the other end held by men which when slowly released will lower the pipe into the trench. After lowering, the pipes shall be arranged so that the spigot of one pipe is carefully centered into the socket of the next pipe, and pushed to the full distance that it can go. The pipe line shall be laid to the levels required. Specials shall also be laid in their proper position as stated above.

**18.4.5.2** Where so directed, the pipes and specials may be laid on masonry or concrete pillars. The pipe laid on the level ground, shall be laid with socket facing the direction of flow of water.

**18.4.5.3** The pipes shall rest continuously on the bottom of the trench. The pipes shall not rest on lumps of earth or on the joints. Four metre long wooden templates may be used to check the level of the bed. Clearance of approximately 100 mm in depth and width equal to length of the collar plus 30mm on both sides shall be provided at the joint which shall be refilled from sides after the joint is made.

**18.4.5.4** In unstable soils, such as soft soils and dry lumpy soils it shall be checked whether the soils can support the pipe lines and if required suitable special foundation shall be provided.

**18.4.5.5** Some clayey soils (for example black cotton soil) are drastically affected by extremes of saturation and dryness. In changing from saturated to a dry condition, these soils are subjected to extraordinary shrinkage which is usually seen in the form of wide and deep cracks in the earth surface and may result in damages to under ground structures, including pipe materials. The clay forms a tight gripping bond with the pipe, subjecting it to excessive stresses as the clay shrinks. It is recommended that in such cases an envelope of a minimum 100 mm of tamped sand shall be made around the pipe line to avoid any bonding.

**18.4.5.6** In places where rock is encountered, cushion of fine earth or sand shall be provided for a depth of 150 mm by excavating extra depth of the trench, if necessary, and the pipes laid over the cushion. Where the gradient of the bed slopes is more than 30 degree it may be necessary to anchor a few pipes against sliding downwards (Fig. 18.8).

### **18.6 LAYING AND JOINTING OF G.I. PIPES (EXTERNAL WORK)**

**18.6.0** The specifications described in 18.4 shall apply, as far as applicable.

#### **18.6.1 Trenches**

The galvanised iron pipes and fittings shall be laid in trenches. The widths and depths of the trenches for different diameters of the pipes shall be as in Table 18.11.

**TABLE 18.11**

<i>Dia of pipe (mm)</i>	<i>Width of trench (cm)</i>	<i>Depth of trench (cm)</i>
15 to 50	30	60
65 to 100	45	75

At joints the trench width shall be widened where necessary. The work of excavation and refilling shall be done true to line and gradient in accordance with general specifications for earth work in trenches. When excavation is done in rock, it shall be cut deep enough to permit the pipes to be laid on a cushion of sand minimum 7.5 cm deep.

### **18.6.2 Cutting and Threading**

Where the pipes have to be cut or rethreaded, the ends shall be carefully filed out so that no obstruction to bore is offered. The end of the pipes shall then be carefully threaded conforming to the requirements of IS 554 with pipe dies and tapes in such a manner as will not result in slackness of joints when the two pieces are screwed together. The taps and dies shall be used only for straightening screw threads which have become bent or damaged and shall not be used for turning of the threads so as to make them slack, as the later procedure may not result in a water tight joint. The screw threads of pipes and fitting shall be protected from damage until they are fitted.

### **18.6.3 Jointing**

The pipes shall be cleaned and cleared of all foreign matter before being laid. In jointing the pipes, the inside of the socket and the screwed end of the pipes shall be oiled and rubbed over. **Teflon Tape** should be used on threads instead of 'Dhaaga/ Safeda'. The end shall then be screwed in the socket, Tee etc. with the pipe wrench. Care shall be taken that all pipes and fittings are properly jointed so as to make the joints completely water tight and pipes are kept at all times free from dust and dirt during fixing. Burr from the joint shall be removed after screwing. After laying, the open ends of the pipes shall be temporarily plugged to prevent access of water, soil or any other foreign matter.

### **18.6.4 Thrust Blocks (Fig. 18.8)**

In case of bigger diameter pipes where the pressure is very high, thrust blocks of cement concrete 1:2:4 (1 cement: 2 coarse sand: 4 graded stone aggregate of 20 mm nominal size) of adequate size and shape shall be provided on all bends to transmit the hydraulic thrust to the ground, spreading it over a sufficient areas, depending upon the type of soil met with.

### **18.6.5 Painting**

The pipes shall be painted with two coats of anticorrosive bitumastic paint of approved quality.

### **18.6.6 Testing of Joints**

The pipes and fittings after they are laid and jointed shall be tested to hydraulic pressure of 6 Kg/sq. cm (60 meter). The pipes shall be slowly and carefully charged with water allowing all air to escape and avoiding all shock or water hammer. The draw off taps and stop cocks shall then be closed and specified hydraulic pressure shall be applied gradually. Pressure gauge must be accurate and preferably should have been recalibrated before the test. The test pump having been stopped, the test pressure should be maintained without loss for at least half an hour. The pipes and fittings shall be tested in sections as the work of laying proceeds, having the joints exposed for inspection during the testing. Pipes or fittings which are found leaking shall be replaced and joints found leaking shall be redone, without extra payment.

### **18.6.7 Trench Filling**

The pipes shall be laid on a layer of 7.5 cm sand and filled up to 15 cm above the pipes. The remaining portion of the trench shall then be filled with excavated earth as described in 20.3.7. The surplus earth shall be disposed off as directed.

### **18.6.8 Measurements**

The lengths shall be measured in running metre correct to a cm for the finished work, which shall include G.I. pipe and G.I. fittings such as bends, tees, elbows reducers, crosses, plugs, sockets, nipples and nuts, but exclude brass or gun metal taps (cocks), valves, unions, lead connection pipes and shower rose. All pipes and fittings shall be classified according to their diameters, method of jointing and fixing substance quality and finish. In case of fittings of an equal bore the pipe shall be described as including all cuttings and wastage. In case of fittings of unequal bore the largest bore shall be measured.

**Note:** G.I. unions shall be paid for separately in external work as well as in internal work. Digging and refilling of trenches shall either be measured separately as specified in the appropriate clauses of excavation and earth work or clubbed with main item.

### **18.6.9 Rate**

The rate shall include the cost of labour and materials involved in all the operations described above. The rate shall not include excavation in trenches, painting of pipes and sand filling all round the pipes, unless otherwise specified.

## **18.7 LAYING AND JOINTING G.I. PIPES (INTERNAL WORK)**

**18.7.0** For internal work the galvanised iron pipes and fittings shall run on the surface of the walls or ceiling (not in chase) unless otherwise specified. The fixing shall be done by means of standard pattern holder bat clamps, keeping the pipes about 1.5 cm clear of the wall. When it is found necessary to conceal the pipes, chasing may be adopted or pipes fixed in the ducts or recess etc., provided there is sufficient space to work on the pipes with the usual tools. The pipes shall not ordinarily be buried in walls or solid floors. Where unavoidable, pipes may be buried for short distances provided adequate protection is given against damage and where so required joints are not buried. Where directed by the Engineer-in-Charge, a M.S. tube sleeve shall be fixed at a place the pipe is passing through a wall or floor for reception of the pipe and to allow freedom for expansion and contraction and other movements. In case the pipe is embedded in walls or floors it should be painted with anticorrosive bitumastic paints of approved quality. The pipe shall not come in contact with lime mortar or lime concrete as the pipe is affected by time. Under the floors the pipes shall be laid in layer of sand filling as done under concrete floors. All pipes and fittings shall be fixed truly vertical and horizontal unless unavoidable. The pipes shall be fixed to walls with standard pattern holder bat clamps of required shape and size so as to fit tightly on the pipes when tightened with screwed bolts, these clamps shall be embedded in brick work in cement mortar 1:3 (1 cement: 3 coarse sand), and shall be spaced at regular intervals in straight lengths as shown in Table 18.12. The clamps shall be fixed at shorter lengths near the fittings as directed by the Engineer-in-Charge. For G.I. pipes 15 mm diameter, the holes in the walls and floors shall be made by drilling with chisel or jumper and not by dismantling the brick work or concrete. However, for bigger dimension pipes the holes shall be carefully made of the smallest size as directed by the Engineer-in-Charge. After fixing the pipes the holes shall be made good with cement mortar 1:3 (1 cement: 3 coarse sand) and properly finished to match the adjacent surface.

**TABLE 18.12**

<i>Dia. of Pipe (mm)</i>	<i>Horizontal length m</i>	<i>Vertical length m</i>
15	2	2.5
20	2.5	3
25	2.5	3
32	2.5	3
40	3	3.5
50	3	3.5
65	3.5	5
80	3.5	5

Unions will be provided to facilitate connections additions and alterations as well as for maintenance and for change of pipes. The locations where unions are to be provided will be decided with prior written approval of the Engineer-in-Charge.

### **18.7.1 Measurements**

The lengths shall be measured in running metre correct to a cm for the finished work, which shall include G.I. pipe and G.I. fittings such as bends, tees elbows, reducers, crosses, plugs, sockets, nipples and nuts, but exclude brass or gun metal taps (cocks), valves, unions, lead connection pipes and shower rose. All pipes and fittings shall be classified according to their diameters, method of jointing and fixing substance, quality and finish. In case of fittings of an equal bore the pipe shall be described as including all cuttings and waste. In case of fittings of unequal bore, the largest bore shall be measured. Pipes laid in trenches (or without supports) and pipes fixed to walls, ceilings, etc. with supports shall be measured separately.

### **18.7.2 Rate**

The rate shall include the cost of labour and material involved in all the operations described above. The rate shall include the cost of cutting holes in walls and floors and making good the same. This shall not however, include concealed pipe work in which case cutting of chase and making good shall be paid separately. It shall not include painting of pipes and providing sleeves, unless specified otherwise. It will also not include union which shall be paid for separately.

## **18.11 MAKING CONNECTION OF G.I. DISTRIBUTION BRANCH WITH G.I. MAIN**

### **18.11.1 Preliminary Work**

A pit of suitable dimensions shall be dug at the point where the connection is to be made with the main and earth removed up to 15 cm below the main. The flow of water in the water main shall also be disconnected by closing the sluice or wheel valves on the mains.

### **18.11.2 Making Connection**

For cutting and jointing 18.6.2 and 18.6.3 shall apply. The G.I. main shall first be cut. Water if any collected in the pit shall be bailed out and, ends of the G.I. pipes threaded. The connection of distribution pipe shall then be made after fixing G.I. tee of the required size to the G.I. main and fittings such as Jam nut, G.I. socket connecting piece etc.

### **18.11.3 Testing of Joints**

After laying and jointing, the pipes and fittings shall be inspected under working condition of pressure and flow. Any joint found leaking shall be redone and all leaking pipes removed and replaced without extra payment. The pipes & fittings after they are laid shall be tested to hydraulic pressure of 6 kg./sq.cm. (60 m). The pipes shall be slowly and carefully charged with water allowing all air to escape and avoiding all shock of water hammer. The draw of laps and stop cocks shall then be closed and specified hydraulic pressure shall be applied gradually. Pressure gauge must be accurate and preferably should have been recalibrated before the test. The test pump having been stopped, the test pressure should be maintained

without loss for at least half an hour. The pipes and fittings shall be tested in sections as the work of laying proceeds, having the joints exposed for inspection during the testing.

#### **18.11.4 Finishing**

The portion of the pipe in the pit shall be painted with bitumastic paint and encased with sand 15 cm all-round. The pit shall be filled with earth in level with the original ground surface watered, rammed and the area dressed.

#### **18.11.5 Measurements**

The work of making connections shall be enumerated.

#### **18.11.6 Rate**

The rate shall include the cost of labour and materials involved in all the operations described above.

### **18.12 FIXING BRASS AND GUN METAL WATER FITTINGS**

**18.12.0** The fitting shall be fully examined and cleared of all foreign matter before being fixed. The fitting shall be fitted in the pipe line in a workman like manner. The joints between fittings and pipes shall be leak-proof when tested to a pressure of 17.5 kg/sq.cm. The defective fittings and joints shall be replaced or redone.

#### **18.12.1 Measurements**

Fittings shall be enumerated.

#### **18.12.2 Rate**

The rate shall include cost of all the material and labour involved in all the operation described above.

### **18.13 FIXING FERRULES**

**18.13.1** For fixing ferrule the empty main shall be drilled and tapped at 45 degree to the vertical and the ferrule screwed in. The ferrule must be so fitted that no portion of the shank shall be left projecting within the main into which it is fitted.

#### **18.13.2 Measurements**

Ferrule shall be enumerated.

#### **18.13.3 Rate**

The rate shall include the cost of all materials and labour involved in fixing the ferrule.

### **18.18 POLYETHYLENE WATER STORAGE TANKS**

#### **18.18.1 Material**

Polyethylene used for manufacture of tanks and manhole lids may be high density (HDPE), low density (LDPE) or linear low density (LLDPE) and shall conform to IS 10146. Polyethylene shall be compounded with carbon black so as to make the tank resistant to ultra violet rays from the sun. The percentage of carbon black content in polyethylene shall be  $2.5 \pm 0.5$  percent and it shall be uniformly distributed. The materials used for the manufacture of tank, manhole lid and fittings shall be such that they neither contaminate the water nor impart any taste, colour, odour or toxicity to water.

#### **18.18.2 Manufacture and Finish**

The tanks shall be manufactured by rotational moulding process. Each tank and the manhole lid shall be single piece having arrangement for fixing and locking the manhole lid with the



tanks. Excess material at the mould parting line and near the top rim shall be neatly cut and finished. The internal and external surface of the tanks shall be smooth, clean and free from hidden internal defects like air bubbles, pit and metallic or other foreign material inclusion. Capacity of the tank, minimum weight of the empty tank (without manhole lid) and the manufacture brand name shall be embossed on the top surface of the tank near manhole.

#### **18.18.3 Shape, Size and Capacity**

The tank shall be cylindrical vertical with closed top having a manhole. Diameter and height of the tank of various capacities shall be as per manufacturer's specifications and a clearance of  $\pm 3$  percent shall be permitted on these dimensions. Capacity of the tank or up to the bottom of the inlet location whichever is less. Capacity of the tank shall be specified. Extra capacity if any shall be ignored.

#### **18.18.4 Weight and Wall Thickness**

Minimum weight of the empty tank (exclusive of manhole lid fittings) and the minimum wall thickness of top, bottom and sides shall be specified in Table 18.23. Wall thickness shall be checked beyond 150 mm of the edge where the direction the plane of tank surface changes.

#### **18.18.5 Installation and Fittings**

The flat base of the tank shall be fully supported over its whole bottom area on a durable rigid flat and level platform sufficiently strong to stand without deflection the weight of the tank when fully filled with water. Depending upon the capacity and location tanks may be suitably anchored as per the directions of the Engineer-in-Charge. For inlet, outlet and other connections fully threaded GI, HDPE or PVC connections with hexagonal check nuts and washers on either side of the tank wall shall be provided. Holes for threaded connections shall be drilled and not punched. Pipes entering or leaving the tank shall be provided with unions and suitably supported on a firm base to avoid damage to the tank walls.

#### **18.18.6 Manhole Lid**

The lid shall rest evenly and fit over the rim of the manhole so as to prevent the ingress of any foreign matter into the tank. The lid shall be provided with suitable arrangement for locking it with the tank.

**18.18.7** The tank and its components shall conform to the local bye-laws for preventions of mosquito menace.

#### **18.18.8 Measurements**

Dimensions shall be measured to the nearest cm. and weight of the empty tank shall be recorded to the nearest 100g. Capacity of the tank as defined in 18.18.3 shall be calculated to the nearest litre.

**TABLE 18.23**

S. No.	Capacity litres	Minimum Wall Thickness mm	Minimum Weight of Empty Tank kg
1	2	3	4
1.	200	4.4	7.8
2.	300	4.4	9.0
3.	400	5.5	15.0
4.	500	6.0	18.0
5.	700	6.6	23.5
6.	1000	7.0	33.0
7.	1250	7.0	40.0
8.	1500	7.0	47.0
9.	1700	7.0	54.0
10.	2000	8.2	64.0
11.	2500	8.2	81.0
12.	3000	8.8	96.0
13.	4000	10.4	138.0
14.	5000	10.7	191.0
15.	6000	10.7	209.0
16.	7500	10.7	250.0
17.	10000	11.5	363.0
18.	15000	11.5	550.0
19.	20000	13.2	814.0

**18.18.9 Rates**

The rate shall include the cost of the tank, manhole lid, carriage and delivery at the place specified. Hoisting, installation, fittings, platform and anchoring shall be payable separately.

**18.20 CUTTING HOLES IN WALL UPTO 30 × 30 CM**

**18.20.0** Square holes of size as specified or as directed by the Engineer-in-Charge shall be cut in the masonry. Any damage to the adjoining portion or to any other item shall be made good as directed by the Engineer-in-Charge. All dismantled material shall be removed from the site.

**18.20.1 Masonry Work**

Brick work etc. shall be made good by using the same class of brick, tile or stone masonry as was cut during the execution of work. The mortar to be used shall be cement mortar 1:4 (1 cement: 4 fine sand) or as directed by the Engineer-in-Charge.

**18.20.2 Finishing**

Cement mortar in 1:4 mix (1 cement: 4 sand) shall be used for plastering or pointing, as may be required. Sand shall be fine or coarse, as used in the original work. The surface shall be finished with two or more coats of white wash, colour wash, distemper or painting as required but where the surface is not to be white washed, colour washed, distempered or painted; it shall be finished smooth with a floating coat of neat cement or as required to match with the surrounding surfaces.

**18.20.3 Measurements**

The holes shall be enumerated.

**18.20.4 Rate**

The rate shall include the cost of labour and materials required for all the operations described above.

**18.21 CUTTING HOLES IN R.C.C. FLOORS (UPTO 15 × 15 CM)**

**18.21.0** Square holes of size as specified shall be cut in R.C.C. floor and roofs for passing drain pipe etc. Any damage to the adjoining portion or to any other item shall be made good

as directed by the Engineer-in-Charge. All the dismantled material shall be removed from the site.

#### **18.21.1 Cement Concrete**

After insertion of drain pipe etc. the hole shall be repaired with cement concrete 1:2:4 (1 cement: 2 coarse sand: 4 graded stone aggregate 20 mm nominal size) and the surface finished to match with the existing surface. The top and bottom shall be finished properly to make the joint leak proof. The specifications for cement concrete work and finishing etc. shall be the same as detailed under relevant sub-heads.

#### **18.21.2 Measurements**

Holes shall be enumerated.

#### **18.21.3 Rate**

The rate shall include the cost of labour and material required for all the operations described above except the pipe which shall be paid for separately.

### **18.22 CUTTING CHASES IN MASONRY WALLS**

#### **18.22.1 Making Chases**

Chases are made in the walls for housing G.I. Pipes etc.

##### ***I. Cutting of chases in one brick thick and above load bearing walls :***

(i) As far as possible services should be planned with the help of vertical chases. Horizontal chases should be avoided.

(ii) The depths of vertical chases and horizontal chases shall not exceed one third and one sixth of the thickness of the masonry respectively.

(iii) When narrow stretches of masonry (or short lengths of walls) such as between doors and windows, cannot be avoided, they should not be pierced with openings for soil pipes or waste pipes or timber joints, etc. Where there is a possibility of load concentration, such narrow lengths of walls shall be checked for stresses and high strength bricks mortar or concrete walls provided, if required.

(iv) Horizontal chases when unavoidable should be located in the upper or lower one third of height of storey and not more than three chases should be permitted in any stretch of a wall. No continuous horizontal chase shall exceed one metre in length. Where unavoidable, stresses in the affected area should be checked and kept within the permissible limits.

(v) Vertical chases should not be closer than 2 m in any stretch of a wall. These shall be kept away from bearings of beams and lintels. If unavoidable, stresses in the affected area should be checked and kept within permissible limits.

(vi) Masonry directly above a recess, if under than 30 cm (Horizontal dimension) should be supported on lintel. Holes in masonry may be provided up to 30 cm width x 30 cm height without any lintel. In the case of circular holes in masonry, no lintel should be provided up to 40 cm in diameter.

##### ***II. Cutting of chases in half brick load bearing walls***

No chase shall be permitted in a half brick load bearing wall and as such no recessed conduits and concealed pipes shall be provided in half brick thick load bearing walls.

##### ***III. Cutting of chases in half brick non-loading bearing walls***

In case of non load bearing half brick walls services should be planned with the help of vertical chases. Horizontal chases should be provided only when unavoidable.

##### ***IV. Cutting of chases in stone masonry walls***

The provision (i) to (vi) under Sl. No. I are equally applicable to stone masonry walls also.

**Note:**

1. No inclined chase shall be permitted in brick masonry or stone masonry walls. In case inclined chases are unavoidable these shall be cut with written approval of the Engineer-in-Charge, and shall be repaired properly to his satisfaction. However, in half brick masonry wall, no inclined chase will be permitted.

2. Chases shall be made by chiseling out the masonry to proper line & depth. Any damage to the adjoining portion or to any other item shall be made good, as decided by the Engineer-in-Charge, for which no extra payment shall be made. All dismantled material shall be removed from site.

#### **18.22.2 Filling Chases**

After G.I. Pipes etc. are fixed in chases, the chases shall be filled with cement concrete 1:3:6 (1 cement: 3 coarse sand: 6 graded stone aggregate 20 mm nominal size) or cement mortar 1:4 (1 cement: 4 coarse sand) as may be specified or otherwise directed by the Engineer-in-Charge and made flush with the masonry surface. The concrete surface shall be roughened with wire brushes to provide a key for plastering.

#### **18.22.3 Measurements**

Chases shall be measured in running meter correct to a cm.

#### **18.22.4 Rates**

The rate shall include the cost of labour the materials involved in all the operations described above excluding the cost of providing pipes etc. which shall be paid separately.

**Note:- For further detail refer CPWD specification volume 2, Sub Head 18.0**

**SUB HEAD : 22.0**  
**WATER PROOFING TREATMENT**

**22.0 TERMINOLOGY**

**Water Bars**

Water bars are preformed strips of impermeable materials which are embedded in the concrete during construction.

**Low Partition Walls**

Parapet walls of height less than 45 cm.

**Expansion Joints**

Joints provided in the structure to allow for thermal expansion/construction.

**Blended Cement**

Cement mixed with water proofing compound in liquid or powder form.

**22.3 WATER PROOFING TREATMENT TO VERTICAL AND HORIZONTAL SURFACE OF DEPRESSED PORTION OF WC, KITCHEN AND THE LIKE**

**22.3.1 Before the Water Proofing Treatment**

Before the water proofing treatment, the internal plaster of ceiling and walls of WC block leaving the portion for dado/skirting should be completed. Grooving / chasing for doing the concealed work of GI/CI pipes/Electrical conduits should be completed. Cleaning the depressed/sunken portion of WC of all debris, extra mortar sticking to the vertical and horizontal surface etc. Necessary holes for 'P' trap /Nhani trap/Water escape pipe etc should be completed.

**22.3.2 Preparing Surface and Fixing Pipes and Fittings**

Before the water proofing treatment work, proper key in the concrete surface should be provided. The depressed/sunken portion should be hacked by a hacking tool, after the concrete slab is cast and when this concrete is still green. The vertical surfaces of the depressed /sunken portion should be hacked with a hacking tool just after the shuttering is removed. In case of old work, the water proofing treatment on such surfaces shall be permitted after making proper spatter dash key. Fixing the 'P' trap in position and all other pipes work including the water escape pipe shall be fixed properly and the holes should be plugged carefully before taking up the water proofing work.

**22.3.3 1st Course**

Cement duly blended with water proofing compound as explained in clause 22.1 shall be used for preparing the cement slurry. The consistency of the slurry should be such that 4.4 kg. of blended cement with water proofing compound is used per sq. metre area of surface to be treated. The slurry should be started from the vertical faces towards the bottom of the floor as shown in Fig. 22.4. Particular care should be taken to see that the slurry is applied to corners without leaving any gap.

**22.3.4 2nd Course**

Immediately on applying the blended cement slurry on the surface to be treated cement plaster 20 mm thick in CM 1:3 (1 blended cement: 3 coarse sand) shall be applied both on vertical and horizontal surfaces taking particular care to complete the entire depressed/sunken portion of WC within a day so that the plaster can be done without any joint. Junctions shall be properly rounded. The surfaces of the plaster shall be left rough but

finished in one plain and cured for a week. On completion of the curing period both horizontal and vertical surfaces shall be cleaned properly and gently and allowed to dry.

#### **22.3.5 3rd Course**

Only after the surface is completely dried the blown or residual bitumen shall be applied @ 1.7 kg. of bitumen per sqm area.

#### **22.3.6 4th Course**

PVC sheet 400 micron thick shall be spread evenly without any kink immediately, so that the PVC sheet sticks to the surface firmly. PVC sheet shall be continued to be laid over the main slab upto 100 mm. Overlapping of PVC sheet should be done with a minimum overlap of 100 mm, duly pasting the overlapped sheet with an application of bitumen @ 1.7 kg./sqm. The projections of pipes and 'P' trap outlet etc. inside the depressed/sunken portion of WC shall also be clad with water proofing treatment layer upto a height of 150 mm, using a coat of bitumen with PVC sheet complete. The surfaces of depressed/sunken portion of WC shall not be left without covering with specified filling material and base concrete, otherwise the PVC sheet layer may be tampered by the labour working in the vicinity. Fixing up of WC pan, filling specified material and the top base concrete should be done as early as possible and the top horizontal layer of water proofing may be taken up later i.e. just before laying the floor tiles.

#### **22.3.7 Measurement**

Length and breadth shall be measured along the finished surface correct to a cm. and area shall be worked out to nearest 0.01 sqm. No payment however shall be made for the 100 mm overlap of PVC Sheet over the roof slab.

#### **22.3.8 Rate**

The rate shall include the cost of labour and materials involved in all the operations described above.

### **22.5 WATER PROOFING TREATMENT IN SUNKEN PORTION OF WCs, BATHROOMS ETC.**

#### **22.5.1 Preliminaries to be Attended**

The preliminaries shall be attended as described in clause 22.3.1.

#### **22.5.2 Preparing Surface, Fixing Pipes and Fittings**

In this case, unlike as described in clause 22.3.2, no hacking of surface need be made, but only extra mortar sticking to the surface should be removed and the surface should be cleaned thoroughly. Fixing 'P' trap etc. shall be done as described in Clause 22.3.2.

#### **22.5.3 Providing and Laying of Slurry for First Layer**

The consistency of the slurry should be such as to cover the desired area by using 0.488 kg of blended cement per sqm of area. On deciding the correct quantity of water required per sqm. area the required quantity of slurry should be prepared which can be applied over the desired surface within half an hour of mixing with 0.488 kg. of grey cement + 0.253 kg. water proofing compound as per manufacturer specifications + x litres of water per sqm. area and the required quantity of slurry thus prepared should only be used for first application. The first layer shall be applied with painting brushes over the specified and dampened area carefully including the corners, holes on the surfaces and joints of pipes in concrete etc. and the application should continue at least upto 150 mm height of fixtures of pipes from the surface. The surface on application shall be air cured for 4 hours.

#### **22.5.4 Providing and Laying of Slurry for Second Layer**

The quantity of slurry required for second application to be covered within an hour of mixing shall be prepared with 0.242 kg. cement + 0.126 kg. water proofing compound + y litres of water per sqm. Area and the required quantity of slurry thus prepared should only be used for second application. The application of 2nd layer of slurry is same as for first layer as detailed in clause 22.5.3. The applied surface shall be allowed to air cure for 4 hours and thereafter water curing shall be done for full 48 hours. In case no further work as described above is to be taken up immediately on completion of water proofing treatment due to any reason it is recommended to protect the treated portion with cement plaster 1:4 as a protective layer for which separate payment shall be made to the contractor.

#### **22.5.5 Measurement**

Length and breadth shall be measured along the finished surface correct to a cm and area shall be worked out to nearest 0.01 sqm.

#### **22.5.6 Rate**

The rate shall include the cost of all labour and materials involved in all the operations described above. The cost of plastering shall be measured and paid for separately.

### **22.9 GRADING ROOF WITH CEMENT CONCRETE 1:2:4**

#### **22.9.1 Materials**

Cement, coarse sand and graded stone aggregate 20 mm nominal size, shall be used as specified in the item. The specifications for the materials and method of preparation of concrete shall conform in general to the specification described in sub-head 4.0 of CPWD Specifications.

**22.9.1.1 Laying:** Before laying cement concrete for grading, the level markings to the required slope/gradient shall be made only with cement concrete on the surface of the slab at suitable spacing with the help of string and steel tape (Measuring tape) so that the mason can lay the concrete to the required thickness, slope / gradient easily in between the two level markings. On getting the level marking approved by the Site Engineer the surface should be sprinkled with thick cement slurry and the concrete should be laid carefully, without throwing from height, in predetermined strips. The concrete should be consolidated by specially made wooden tamping. After the tamping is done the surface should be finished to required slope/gradient with wooden trowels without leaving any spots of loose aggregates etc. The mixed cement concrete must be laid in position, within half an hour of its mixing. In case any quantity of concrete remains unused for more than half an hour the same should be rejected and removed from the site.

**22.9.1.2 Finishing:** The slope of finished terrace shall not be more than 1 in 120 unless a steeper slope is desired by the Engineer-in-Charge. The minimum thickness of the concrete at its junction with Khurra or parapets shall be 5 cm. The concrete shall be rounded at the junction of roof slab and parapet. It is desirable to provide a haunch/gola/filler at the junction of the parapet wall and the roof slab as shown in Fig. 22.8. The finished concrete surface shall present a smooth surface with correct slopes and uniform rounding. The concrete should be free from cracks. Excess trowelling shall be avoided.

**22.9.1.3 Thickness:** Average thickness shall be as per clause 22.9.1.2 as shown in Fig. 22.8.

**22.9.1.4 Curing:** Curing shall be done either by spreading straw/Hessian cloth over the graded surface, keeping the same wet for full 10 days or flooding the graded area with water by making kiaries with weak cement mortar, for 10 days. Occasional curing by simply spraying water now and then shall not be permitted under any circumstances.

**22.9.1.5 Measurement:** Length and breadth shall be measured correct to a cm. Area shall be worked out to nearest 0.01 sqm. and the cubical contents shall be worked out to nearest 0.001 cum. No deduction shall be made for either opening or recesses for chimney stacks, roof lights etc., Khurra for area upto 0.1 sqm. Nothing extra shall be paid either for any extra material or labour involved in forming such opening or recess or in rounding the concrete function of roof with parapet walls, chimney stack, khurra etc.

**22.9.1.6 Rate:** The rate shall include the cost of all the materials and labour involved in all the operations described above.

## **22.10 GRADING ROOF WITH CEMENT MORTAR**

### **22.10.1 Materials**

Cement and coarse sand shall be as specified in the item of work or as described in sub-head 3.0 of CPWD Specifications.

**22.10.1.1 Cement Mortar :** Cement mortar 1:3 (1 cement: 3 coarse sand) /1:4(1 cement: 4 coarse sand) specified in the item of work shall conform to the specification described in sub-head 3.0 of CPWD Specifications.

**22.10.1.2 Preparation of the Surface:** The surface shall be cleaned properly with brooms brush, cloth to remove all dirt, dust, mortar droppings.

**22.10.1.3 Laying:** Same as described in clause 22.9.1.1, except that cement mortar shall be tamped with wooden and steel trowels and surface finished with steel trowel.

### **22.10.1.4 Finishing**

(i) The slope of finished surface shall not be more than 1 in 120 unless a steeper slope is specified in the item of work.

(ii) The finished surface of the grading shall present a smooth surface with correct slopes and uniform roundings wherever they are provided. The mortar surface shall be free of cracks. Excess trowelling shall be avoided.

**22.10.1.5 Thickness:** The minimum thickness of cement mortar grading at the junction with khurra or parapet wall shall be 20 mm. The cement mortar shall be rounded at the junction of roof slab and parapet. It is desirable to provide a haunch/gola/filler at the junction of parapet wall and the roof slab. The maximum thickness that shall be adopted for grading with cement mortar shall be 50 mm. It is not at all desirable to lay the cement mortar grading for greater thickness and in that case it is advised to go in for grading with Cement Concrete. The average thickness shall be as shown in Fig. 22.9 and 22.10.

**22.10.1.6 Curing:** Curing for the grading with cement mortar shall be done exactly as described in clause 22.9.1.4.

**22.10.1.7 Measurement:** Same as specified in clause 22.9.1.5.

**22.10.1.8 Rate:** The rate shall include the cost of all the labour and material involved in all the operations described above.

**Note:- For further detail refer CPWD specification volume 2, Sub Head 22.0**



**SUB HEAD : 23.0  
HORTICULTURE  
AND LANDSCAPE**

**23.0 HORTICULTURE WORK**

Horticultural operations shall be started on ground previously levelled and dressed to required formation levels and slopes. In case where unsuitable soil is met with, it shall be either removed or, replaced or it shall be covered over to a thickness decided by the Engineer-in-charge with good earth. In the course of excavation or trenching during horticultural operations, any walls, foundations, etc. met with shall not be dismantled without pre-measurement and prior to the written permission of the Engineer-in-charge.

**23.1 TRENCHING IN ORDINARY SOIL**

**23.1.0** Trenching is done in order to loosen the soil, turn over the top layer containing weeds etc. and to bring up the lower layer of good earth to form a proper medium for grassing, regrassing, hedging and shrubbery. Trenching shall be done to the depth ordered by the Engineer-in-charge. The depth is generally 30 cm for grassing and 60 cm for regrassing in good soil.

**23.1.1** The trenched ground shall, after rough dress, be flooded with water by making small kiaries to enable the soil to settle down. Any local depression unevenness etc. shall be made good by dressing and/or filling with good soil.

**23.1.2** Weeds or other vegetation which appear on the ground are then uprooted and removed and disposed off and paid.

**23.1.3 Trenching**

Trenching shall consist of the following operations:

1. The whole plot shall be divided into narrow rectangular strips of about 1.5 m width or as directed by the Engineer-in-Charge.
2. These strips shall be sub-divided lengthwise into about 1 m long sections. Such sections shall be excavated serially and excavated soil deposited in the adjacent section preceding it.
3. In excavating and depositing care shall be taken that the top soil with all previous plant growth including roots, get buried in the bottom layer of trenched area, the dead plants so buried incidentally being formed into humus.
4. The excavated soil shall be straight away dumped into the adjoining sections so that double handling otherwise involved in dumping the excavated stuff outside and in back filling in the trenches with leads is practically eliminated.

**23.1.4 Measurements**

Length and breadth of the plot shall be taken correct to 0.1 m and depths correct to cm. Cubical contents shall be calculated in cubic meters, correct to two places of decimal. No deduction shall be made nor extra paid for removing stones, brick bats and other foreign matter met with during excavation upto initial lead of 50 m and stacking the same.

**23.1.5 Rate**

The rate shall include the cost of all labour and material involved in the operations described above, including cost of all precautionary measures to be taken for protections and supporting all services etc. met with during trenching. It does not include the cost of mixing of earth, sludge/manure.

**23.2 GOOD EARTH**

**23.2.1** The earth shall be stacked at site in stacks not less than 50 cm high and of volume not less than 3.0 cum.

**23.2.2 Measurements:** Length, breadth and height of stacks shall be measured correct to a cm. The volume of the stacks shall be reduced by 20% for voids before payment, unless otherwise described.

**23.2.3 Rate:** The rate shall include the cost of excavating the earth from areas lying at distance not exceeding one km. from the site, transporting the same at site breaking of clods and stacking at places indicated. The rate shall also include royalty if payable.

### **23.3 OIL CAKE**

**23.3.1 Neem/Castor:** The cake shall be free from grit and any other foreign matter. It should be undecorticated and pulverized. The material shall be packed in old serviceable gunny bags of 50 kgs capacity approximately. The weight of gunny bag shall be deducted @1 kg per bag and payment shall be made for net quantity. The quality of cake should be got approved by the Engineer-in-charge before supply.

#### **23.3.2 Measurements**

The arrangement for weighing shall be made at site of work by the department. The gunny bags shall be the property of the government.

**23.3.3 Rate:** The rate shall include the cost of labour and material involved in all operations described above, including carriage up to site of work with all lead and lifts, weighing etc.

### **23.4 SUPPLY AND STACKING OF SLUDGE**

**23.4.1** It shall be transported to the site in lorries with efficient arrangement to prevent spilling enroute. It shall be stacked at site. Each stack shall not be less than 50 cm height and volume not less than 3 cum.

#### **23.4.2 Measurements**

Length, breadth and depth of stacks shall be measured correct to a cm. The volume of the stack shall be reduced by 8% for looseness in stacking and to arrive at the net quantity for payment.

#### **23.4.3 Rate**

The rate shall include the cost of labour and material involved in all operations described above, including carriage up to one km. The rate shall also include royalty if payable.

### **23.5 SUPPLY AND STACKING OF MANURE**

**23.5.1 Farmyard Manure:** Same as 23.4.1.

**23.5.2 Measurements:** Same as 23.4.2.

**23.5.3 Rate :** Same as 23.4.3.

### **23.6 ROUGH DRESSING OF THE TRENCHED GROUND**

**23.6.0** Rough dressing of the area shall include making kiaries for flooding.

**23.6.1** The trenched ground shall be levelled and rough dressed and if there are any hollows and depressions resulting from subsidence which cannot be so levelled, these shall be filled properly with earth brought from outside to bring the depressed surface to the level of the adjoining land and to remove discontinuity of slope and then rough dressed again. The supply and spreading of soil in such depressions is payable separately. In rough dressing, the soil at the surface and for 75 mm depth below shall be broken down to particle size not more than 10 mm in any direction.

**23.6.2 Measurements**

Length, breadth of superficial area shall be measured correct to 0.1 metre. The area shall be calculated in sqm. correct to two places of decimal.

**23.6.3 Rate**

The rate shall include the cost of all the labour and material involved in all the operations described above.

**23.7 UPROOTING WEEDS FROM TRENCHED AREAS**

**23.7.1** After 10 days and within 15 days of flooding the rough dressed trenched ground with water, the weeds appearing on the ground shall be rooted out carefully and the rubbish disposed off as directed by the Engineer-in-charge.

**23.7.2 Measurements**

Length, breadth of superficial area shall be measured correct to 0.1 meters. Superficial area of the weeded ground shall be measured for purpose of payments.

**23.7.3 Rate**

The rate shall include the cost of all the labour and material involved in all the operations described above.

**23.8 FINE DRESSING THE GROUND**

**23.8.1** Slight unevenness, ups, and downs and shallow depressions resulting from the settlement of the flooded ground, in drying and from the subsequent weeding operations, shall be removed by fine dressing the surface to the formation levels of the adjoining land as directed by the Engineer-in-charge, and by adding suitable quantities of good earth brought from outside, if necessary.

**23.8.2 Measurements**

Length, breadth and depth of stacks shall be measured correct to a cm. The area shall be calculated in sqm. correct to two places of decimal.

**23.8.3 Rate**

The rate shall include the cost of all the labour and material involved in all the operations described above.

**23.9 SPREADING GOOD EARTH**

**23.9.1** Good earth shall be removed from stacks by head load and spread evenly over the surface to the thickness ordered by the Engineer-in-charge. It shall be spread with a twisting motion to avoid segregation and to ensure that spreading is uniform over the entire area.

**23.9.2 Measurements:** The quantity of good earth spread shall be determined by the difference in the volume of good earth in stacks before and after spreading duly reduced for looseness in stacking by 20% of good earth.

**23.9.3 Rate:** The rate shall include of all the labour and material involved in all the operations described above, but does not include the cost of the good earth which shall be paid for separately unless specifically described in the item.

### **23.9.A SPREADING SLUDGE/MANURE**

**23.8.A.1** Good earth shall be thoroughly mixed with sludge or manure in specified proportion as described in the item or as directed by the Engineer-in-Charge. The mixing shall be spread as described in 23.9.1 to the thickness ordered by the Engineer-in-Charge.

#### **23.9.A.2 Measurements**

The quantity of good earth and sludge or manure mixed shall be determined by the difference in the volume of good earth and sludge or manure in stack, before and after spreading duly accounted for voids and looseness in stack.

#### **23.9.A.3 Rate**

The rate shall include of all the labour and material involved in all the operations described above, but does not include the cost of good earth sludge or manure which shall be paid for separately, unless otherwise described in the item.

### **23.10 MIXING OF GOOD EARTH AND SLUDGE/MANURE**

**23.10.1** The stacked earth shall, before mixing be broken down top particle of sizes not exceeding 6 mm in any direction. Good earth shall be thoroughly mixed with sludge or manure in specified proportion as described in the item or as directed by the Engineer-in-charge.

#### **23.10.2 Measurements**

The quantity of good earth and sludge or manure mixed shall be determined by the difference in the volume of good earth, sludge or manure in stack, before and after spreading duly accounted for voids and looseness in stack.

#### **23.10.3 Rate**

The rate shall include the cost of all labour and materials involved in all the operations described above, but does not include the cost of good earth sludge or manure which shall be paid for separately, unless otherwise described in the item.

### **23.11 GRASSING WITH SELECT GRASS NO. 1**

**23.11.0** The area from where the grass roots are to be obtained shall be specified by the Engineer-in- Charge at the time of execution of the work and no royalty shall be charged on this account from the contractor. **Grass is to be arranged by contractor (cost of grass to be paid separately).**

**23.11.1** The soil shall be suitably moistened and then the operation of planting grass shall be commenced. The grass shall be dibbled at 10 cm, 7.5 cm, 5 cm apart in any direction or other spacing as described in the item. Dead grass and weeded shall not be planted. The contractor shall be responsible for watering and maintenance of levels and the lawn for 30 days or till the grass forms a thick lawn free from weeded and fit for moving whichever is later. Generally planting in other direction at 15 cm, 10 cm, spacing is done in the case of large open spaces, at 7.5 cm spacing in residential lawn and at 5cm spacing for Tennis Court and sports ground lawn. Rates are including cost of labour and material **(grass shall be paid separately.)**

**23.11.2** During the maintenance period, any irregularities arising in ground levels due to watering or due to trampling by labour, or due to cattle straying thereon, shall be constantly made up to the proper levels with earth as available or brought from outside as necessary, Constant watch shall be maintained to ensure that dead patches are replanted and weeds are removed.

### **23.11.3 Measurements**

Length, breadth of the lawn grassed shall be measured correct to 0.1 meter and the area shall be calculated in sqm. correct to two places of decimal.

### **23.11.4 Rate**

The rate shall include of all the labour and material involved in all the operations described above, excluding supply of the requisite quantity of good earth and grass so needed for properly maintaining the levels of the lawns. **(payment of grass to be paid separately).**

## **23.12 RENOVATION OF LAWNS**

**23.12.1** The area shall be first weeded out of all undesirable growth. The entire grass shall be scrapped (cheeled) without damaging roots and level of the grounds. Slight irregularities in surface shall be levelled off and the area shall then be forked so as to aerate the roots of the grass without, however uprooting them. Specified quantity of sludge or manure shall than be spread uniformly with wooden straight edge (phatti) as directed by the Engineer-in-charge. The area shall then be slightly sprinkled with water so as to facilitate proper integration of the manure or sludge with the soil and later flooded. The contractor shall be responsible for watering, proper maintenance and tending of the lawn for 30 days or till the grass forms a lawn fit for mowing, whichever is later. During the above operations, all undesirable growths shall be constantly weeded out and all rubbish removed and disposed off as directed by the Engineer-in-Charge.

### **23.12.2 Measurements**

Length, breadth of the lawn renovated shall be measured correct to 0.1 meter and the area shall be calculated in sqm. correct to two places of decimal.

### **23.12.3 Rate**

The rate shall include of all the labour and T&P (excluding RH pipe/grass) involved in all the operations described above, excluding the supply of the requisite quantity of good earth if so needed for proper maintenance of the levels of the lawns. The cost of the sludge or manure shall be measured and paid for separately, unless its supply is specifically included in the description of the item.

## **23.13 UPROOTING RANK VEGETATION AND WEEDS AND PREPARING THE GROUND FOR**

### **PLANTING 'SELECT GRASS NO. 1'**

**23.13.1** Initially the area shall be dug up to a depth of 30 cm. and weeds and rank vegetation with roots removed thereon by repeated forking. The whole area then shall be retrenched to a depth of 60 cm in the same manner as described in 23.1. Clods of excavated earth shall then be broken upto the size not more than 75 mm in any direction. The area shall then be flooded with water and after 10 days and within 15 days of flooding, weeds shall be uprooted carefully. The rubbish arising from the above operations shall be removed and disposed off in a manner directed by the Engineer-in-charge, away from the site. The earth shall then be rough dressed and fine dressed as described in 23.6 & 23.8.

### **23.13.2 Measurements**

Length, breadth of uprooted area shall be measured correct to 0.1 meter and the area shall be calculated in sqm. correct to two places of decimal.

### **23.13.3 Rate**

The rate shall include the cost of all the labour and material involved in all the operations described above.

## **23.14 EXCAVATION AND TRENCHING FOR PREPARATION OF BEDS FOR HEDGE AND SHRUBBERY**

**23.14.1** Beds for hedges and shrubbery are generally prepared to width of 60 cm. to 125 cm. and 2 to 4 meters respectively.

**23.14.2** Beds for hedges and shrubbery shall be prepared in the following manner. The beds shall first be excavated to a depth of 60 cm. and the excavated soil shall be stacked on the sides of the beds. The surface of the excavated bed shall then be trenched to a further depth of 30 cm, in order to loosen the soil, in the manner described in 23.1. No flooding will be done at this stage but the top surface shall be rough dressed and levelled. The excavated soil from the top 60 cm depth of the bed stacked at the site shall then be thoroughly mixed with sludge over manure in the proportion 8:1 by ratio or other proportion described in the item. The mixed earth and manure shall be refilled over the trenched bed, leveled neatly and profusely flooded so that the water reaches even the bottom most layers of the trenched depth of the bed. The surface after full subsidence shall again be refilled with the earth and manure mixture, watered and allowed to settle and finally fine dressed to the level of 50 mm to 75 mm below the adjoining ground or as directed by the Engineer-in-Charge. Surplus earth if any, shall be disposed off as directed by the Engineer-in-charge. Any surplus earth if removed beyond initially lead shall be paid separately. Stones, bricks bats and other foreign matter if met with during excavation or trenching shall be removed and stacked within initially lead & lift, such material as is declared unserviceable by the Engineer-in-charge shall be disposed by spreading and levelling at places ordered by him. If disposed outside the initial lead & lift, then the transport for the extra leads will be paid for separately. If a large proportion of material unsuitable for the hedging and shrubbery operations is met with and earth from outside is required to be brought in for mixing with manure and filling, the supply and stacking of such earth will be paid for separately.

### **23.14.3 Measurements**

Length, breadth and depth of the pit excavated and trenched shall be measured correct to a cm. The cubical contents shall be calculated in cubic meter correct to two places of decimal.

### **23.14.4 Rate**

The rate shall include the cost of all the labour and material involved in all the operations described above. The rate shall not include the cost of supply & stacking of the manure unless the same is specifically included in the description of the item.

## **23.15 DIGGING HOLES FOR PLANTING TREES**

**23.15.1** In ordinary soil, including refilling earth after mixing with oil cake, manure and watering.

**23.15.1.1** Holes of circular shape in ordinary soil shall be excavated to the dimensions described in the items and excavate soil broken to clods of size not exceeding 75 mm in any direction, shall be stacked outside the hole, stones, brick bats, unsuitable earth and other rubbish, all roots and other undesirable growth met with during excavation shall be separated out and unserviceable material removed from the size as directed. Useful material, if any, shall be stacked properly and separately. Good earth in quantities as required to replace such discarded stuff shall be brought and stacked at site by the contractor which shall be paid for separately. The tree holes shall be manured with powdered Neam/castor oil cake at the specified rate along with farm yard manure over sludge shall be uniformly mixed with the excavated soil after the manure has been broken down to powder, (size of particle not be exceeded 6 mm in any direction) in the specified proportion, the mixture shall be filled in to the hole up to the level of adjoining ground and then profusely watered and

enable the soil to subside the refilled soil shall then be dressed evenly with its surface about 50 to 75 mm below the adjoining ground level or as directed by the Engineer-in-charge.

**23.15.1.2 Measurements :** Holes shall be enumerated.

**23.15.1.3 Rate:** The rate shall include the cost of all the labour and material involved in all the operations described above, excluding the cost of supply and stacking the requisite quantity of manure/sludge and oil cake.

### **23.15.2 In Soil other than Ordinary Soil**

**23.15.2.1** Where holes are dug in (a) Hard soil (b) Ordinary rock or (c) Hard rock, the above soils occurring independently over in conjunction with each other and /or ordinary soil in any hole, the different excavated soil shall be stacked separately. Excavation in hard rock shall be carried out by chiseling only.

**23.15.2.2** The stack measurement of ordinary rock and hard rock shall be reduced by 50% and of soil by 20% to arrive at the excavated volume. This excavation shall be paid for as extra over the rate for holes dug in ordinary soil above, at rate appropriate to particular soil concerned.

**23.15.2.3** Sufficient quantity of good soil to replace the solid volume of stones, brick bats, unsuitable earth and other rubbish, all roots and other undesirable growth, ordinary and hard stacks shall be brought and stacked at site but the supply and stacking of such shall be paid for separately.

**23.15.2.4** The useless excavated stuff shall be disposed off by spreading at places as ordered by the Engineer-in-charge. If such places are outside initially leads, carriage for the extra lead shall be paid for separately.

**23.15.2.5** The ordinary soil excavated from the hole and the earth brought from outside shall then be mixed with manure screened through sieve of IS designation 16 mm in the proportion specified in the description of the item and filled with the pit and the same watered and finally dressed.

**23.15.2.6 Measurements:** The pit shall be enumerated. The volume of excavation in soil and other than a ordinary soil shall be determined by reducing the stack volume of the relevant soil with respective percentage for voids specified in 23.14.2.2.

**23.15.2.7 Rate:** The rate shall include the cost of all the labour and material involved in all the operations described above, including mixing refilling, watering, dressing etc. but shall not include (a) cost of manure over sludge (b) cost of supplying and stacking of good earth for replacement and (c) the cost of carriage beyond initial lead for disposing off useless materials. The excavation other than that of ordinary soil shall be paid extra over and above the rate if excavation in ordinary soil.

### **23.16 M.S. FLAT IRON TREE GUARD**

#### **23.16.1 M.S. Iron Riveted Tree Guard**

**23.16.1.1** The tree guard shall be 600 mm in diameter and 2 meter high above ground level and 25 cm in below ground level.

**23.16.1.2** The tree guard shall be framed of 4 nos. 25 x 6 mm M.S. flat 2 meter long excluding displayed outward at lower and upto an extent 10 cm and 8 nos. 25 x 3 mm vertical M.S. Flat Rivetted to 3 Nos. 25 x 6 mm Flat iron rings in two halves, bolted together 8 mm dia

and 30 mm long M.S. bolts and nuts. The entire tree guard shall be given two coats of synthetic enamel paint of approved brand and manufacturer of required shade over a priming coat of ready mixed steel primer of approved brand and manufacturer. The design of tree guards shall be shown in the drawing.

**23.16.1.3 Measurement :** The tree guard shall be enumerated.

**23.16.1.4 Rate:** The rate shall include the cost of all the labour and material involved in all the operations described above.

### **23.16.2 M.S. Flat Iron Welded Tree Guard**

**23.16.2.1** The tree guard shall be 600 mm in diameter and 2 meter high above ground level and 25 cm in below ground level.

**23.16.2.2** The tree guard shall be framed of 4 nos. 25 x 6 mm MS. Flat 2 metres long excluding displayed outward at lower and upto an extent 10 cm and 8 Nos. 25 x 3 mm vertical M.S. Flat Riveted to 3 nos. 25 x 6 mm flat iron rings in two halves, bolted together 8 mm dia and 30 mm long M.S. Bolts & nuts. The entire tree guard shall be given two coats of synthetic enamel paint of approved brand and manufacturer of required shade brand and manufacturer of required shade over a priming coat of ready mixed steel primer of approved brand and manufacturer. The design of tree guards shall be shown in the drawing.

**23.16.2.3 Measurement :** The tree guard shall be enumerated.

**23.16.2.4 Rate:** The rate shall include the cost of all the labour and material involved in all the operations described above.

### **23.17 FILLING MIXTURE OF EARTH & SLUDGE OVER MANURE**

**23.17.0** The separately specified earth and sludge shall be broken down to particles of size not exceeding 6 mm in any directions before mixing. Good earth shall be thoroughly mixed with sludge over manure in specified proportions as directed by Officer-in-Charge. During the process of preparing the mixture as above, trenches shall be flooded with water and levelled.

#### **23.17.1 Measurements**

Measurement shall be made in (Length, breadth and height of stacks) cubic meter. The cubical contents shall be worked out to the nearest two places of decimal in cubic meter.

#### **23.17.2 Rate**

The rate shall include the cost of all the labour and material involved in all the operations described above, but do not include the good earth, sludge or manure which will be paid separately.

### **23.18 EXCAVATION OF DUMPED STONE OR MALBA**

**23.18.1** Excavation operations shall include excavation and getting out water if required. During the excavation stone, brick bats and other foreign material if met shall be removed and stacked within 50 meter leads and lifts. Such material as is declared unserviceable by the Engineer-in-Charge be disposed within 50 m. The excavated surface shall be neatly dressed and levelled.

#### **23.18.2 Measurements**

Measurement shall be made in (Length, breadth and height of stacks) cubic meter. The cubical contents shall be worked out to the nearest two places of decimal in cubic meter.



**23.18.3 Rate**

The rate shall include the cost of all the labour and material involve in all the operations described above.

**23.19 EXCAVATION IN BAJRI PATH**

**23.19.1** All excavated operations shall include excavation and stacking of serviceable and unserviceable material. Excavated surface of Bajri path shall be removed and stacked upto 50 meter lead and disposed material neatly dressed.

**23.19.2 Measurements**

Same as 23.18.2.

**23.19.3 Rate**

Same as 23.18.3.

**23.20 EXCAVATION OF WATER BOUND MACADAM**

**23.20.1** All excavated operations shall include excavation, stacking of serviceable and unserviceable material. Excavation shall be straight and uniform in width. Soling stone and aggregate obtained from excavation of W.B.M. shall be stacked separately and unserviceable material disposed off with lead upto 50 meter and lift upto 1.50 meter and neatly dressed.

**23.20.2 Measurements**

Measurement shall be made in (Length, breadth and height of stacks) cubic meter. The cubical contents shall be worked out to the nearest two places of decimal in cubic meter.

**23.20.3 Rate**

The rate shall include the cost of all the labour and material involved in all the operations described above.

**23.21 FLOODING THE GROUND WITH WATER AND MAKING KIARIES**

**23.21.1** The water for flooding shall be of soft water and free from chemical and good for growing the trees and shrubs etc. Before flooding the kiaries shall be made in required size and shape as per directions of Officer-in-charge. After uprooting weeds from the trenched area and uprooting vegetation, kiaries shall be dismantled.

**23.21.2 Measurements**

Measurement shall be made in sqm. of area.

**23.21.3 Rate**

The rate shall be for 100 sqm of area and include the cost of all the labour and material involved in all the operations described above.

**Note:- For further detail refer CPWD specification volume 2, Sub Head 23.0**

**SECTION – 5**

**Technical Specification  
(Electrical)**

**RECOMMENDED MAKE for Electrical, Fire, HVAC & IT works**

<b>List of Make for Electrical Works</b>			
<b>SI No</b>	<b>ITEMS</b>	<b>IS CODE</b>	<b>BRAND NAME</b>
1	Transformer 33 KV Step down	IS-1180-PART 1	1. ABB. 2. Voltamp Transformers Limited.
2	Transformer 11 KV/415V Step down 1001 KVA and above.	IS-1180-PART 1	1. ABB. 2. Voltamp Transformers Limited.
3.	Transformer 11 KV/415V Step down upto 1000 KVA.	IS-1180-PART 1	1. ABB. 2. Voltamp Transformers Limited. 3. PVJ power solution
4.	GOD (Gang operated device) 11 KV and above	2607-1264	1. Pactil Transformers. 2. Rashtriya Electrical & Engg. 3. Areva. 4. Bhel. 5. National Switchgears. 6. Ultima Switchgears Limited.
5	HT Switch Gear 33 KV, VCB	3427 12729	1. ABB. 2. EATON 3. L&T.
6	HT Switch Gear 11 KV, VCB	3427 12729	1. ABB. 2. EATON 3. L&T.
7	HT Switch Gear protection relay Electromechanical / numerical	3231 1986	1. ABB. 2. EATON 3. L&T.
8	HT Ring Main Unit, SF 6/VCB, 11 KV	IEC62271 100- 105	1. ABB. 2. EATON 3. L&T.
9	HT Cable, XLPE 11/6.6 KV	7098	1. HAVELLS 2. GEMSCAB 3. GRANDLAY 4. L.S. CABLE INDIA 5. KEI.
10	Disc Insulator, Pin Insulator 11 KV	2486 Pt I & II	1. BHEL. 2. BPCL. 3. MYSORE. 4. PORCELINE. 5. WS INSULATOR. 6. SOUTHERN INSULATOR. 7. JAYSHREE.
11	HT/LT Steel Tubular Swaged Pole	2713 Pt I to III 1980	1. INDIAN CO. LTD. 2. ANIL ENGG. CORP. 3. BHARAT STEEL TUBES. 4. FABRICO(INDIA). 5. BHARAT CONDUIT & STEEL WORKS. 6. NATIONAL TUBING CO.
12	LT PANEL (TTA TYPE)	IEC 61439-1 AND IEC 61439-3	1. LEGRAND 2. L&T 3. ABB 4.HAVELLS 5. HPL

13	LT Cubical Panel/Feeder Pillar	5039 1983	<ol style="list-style-type: none"> <li>1. LEGRAND</li> <li>2. L&amp;T</li> <li>3. ABB</li> <li>4. HAVELLS</li> <li>5. INDOASIAN</li> <li>6. HPL</li> <li>7. BRIGHT PANAL</li> <li>8. ELECTRO EQUIPMENT</li> <li>9. TRANSCON POWER PVT. LTD.</li> <li>10. RISHA CONTROL ENGINEERS PVT. LTD</li> </ol> <p>Manufacturer Should be approved by CPRI &amp; Design as per IP-55 &amp; IS-8623.</p>
14	HT Panel	-	<ol style="list-style-type: none"> <li>1. ABB.</li> <li>2. EATON</li> <li>3. L&amp;T.</li> </ol>
15	LT/Air Circuit Breaker upto 2000 Amps	13947 -2	<ol style="list-style-type: none"> <li>1. LEGRAND</li> <li>2. HONEYWELL</li> <li>3. INDOASIAN</li> <li>4. BCH ELECTRIC LTD.</li> <li>5. ABB</li> <li>6. EATON</li> <li>7. L &amp; T</li> <li>8. HPL</li> <li>9. HAVELLS</li> </ol>
16	RCC Pole	1678 1978	<ol style="list-style-type: none"> <li>1. CEMENT FABRICS</li> <li>2. RK INDUSTRIES &amp; POLES</li> <li>3. SP WIRES</li> <li>4. CEMENT POLES</li> <li>5.SCC POLES</li> <li>6. CONCRETE UDYOG LTD.</li> </ol>
17	MCCB	13947 -2	<ol style="list-style-type: none"> <li>1. LEGRAND</li> <li>2. HONEYWELL</li> <li>3. INDOASIAN</li> <li>4. BCH ELECTRIC LTD.</li> <li>5. ABB</li> <li>6. EATON</li> <li>7. L &amp; T</li> <li>8. HPL</li> <li>9. HAVELLS</li> </ol>
18	MCB/ISOLATOR/RCCB/ELCB	8828 1978	<ol style="list-style-type: none"> <li>1. LEGRAND</li> <li>2. HONEYWELL</li> <li>3. INDOASIAN</li> <li>4. BCH ELECTRIC LTD.</li> <li>5. ABB</li> <li>6. EATON</li> <li>7. L &amp; T</li> <li>8. HPL</li> <li>9. HAVELLS</li> </ol>

19	Voltmeter / Ammeter / Frequency Meter / Power Factor Meter	722	1. LEGRAND. 2. INDOASIAN. 3. EATON 4. L & T 5. HPL 6. HAVELLS
20	Push Button	IEC-947 -5-1	1. LEGRAND. 2. INDOASIAN. 3. EATON 4. L & T 5. HPL 6. HAVELLS
21	Selector Switch	IEC947 -5-1	1. LEGRAND. 2. INDOASIAN. 3. EATON 4. L & T 5. HPL 6. HAVELLS
22	Indicating Lamp	IEC-947 -5-1	1. LEGRAND. 2. INDOASIAN. 3. EATON 4. L & T 5. HPL 6. HAVELLS 7. BCH
23	Street Light Timers	IEC-60730	1. LEGRAND 2. ABB. 3. L&T. 4. INDO ASIAN. 5. HPL. 6. HAVELLS 7. EATON
24	LT cable 1100 V, XLPE	1554Pt I	1. HAVELLS INDIA LTD. 2. GRANDLAY. 3. GEMSCAB. 4. L.S. CABLE INDIA 5. HPL 6. KEI
25	Main Switch / Change Over Switch	4064 Pt I , II & 13947	1. BCH 2. HAVELLS 3. HPL.4. L & T. 5. ABB. 6. INDOASIAN 7. EATON
26	LT AERIAL BUNCH CABLE (ABC)	IS 14255-1995	1. HAVELLS INDIA LTD. 2. GRANDLAY. 3. GEMSCAB.
27	DG Sets	-	1 CATTERPILLAR 2. ASHOK LEYLAND - HIMONISHA. 3. MAHINDRA POWEROL
28	Thimbles/Studs/Lugs	2315-1978	1. DOWELLS. 2. AXIS. 3. INDIANA. 4. SIGMA.

29	Multistranded Copper FRLS Wires-650 / 1100V	1554 Pt I	1. KEI 2. HAVELLS 3. GEMSCAB 4. HPL. 5. L.S. CABLE INDIA. 6. ANCHOR-PANASONIC 7. GRANDLAY 8. L & T.
30	Thermo Plastic Sockets	-	1. LEGRAND. 2. HONEYWELL 3. INDOASIAN 4. ABB 5. L&T 6. HAVELLS 7. HPL
31	PVC Conduit Pipe (HMS) including Accessories	9537 III 1983	1. ANCHOR 2. POLYCAB 3. AKG
32	MCB-DB (SP-TP)	2675 of 1983	1. LEGRAND 2. HONEYWELL 3. INDOASIAN 4. BCH ELECTRIC LTD. 5. ABB 6. EATON 7. L & T 8. HPL 9. HAVELLS
32	PT Switch / Sockets	4615	1. ANCHOR 2. HAVELLS INDIA LTD 3. HPL
33	Modular Switches / Sockets	-	1. LEGRAND 2. HONEYWELL 3. ABB 4. ANCHOR - PANASONIC 5. HAVELLS
34	Ceiling Rose	371-1979	1. HPL 2. ANCHOR. 3. HAVELLS INDIA LTD.
35	Ceiling fan	374-1979	1. ORIENT (CK BIRLA GROUP) 2. HAVELLS INDIA LTD. 3. CROMPTON GREAVES.
36	Telephone, LAN & co-axial wire/ networking CABLE/ CCTV CABLE/ FIBER CABLE .	-	1. LEGARAND. 2. HAVELLS 3. HPL 4. L.S. CABLE INDIA 5. ANCHOR - PANASONIC
37	LED Street Light Fitting & FLOOD LIGHTS	-	1. CROMPTON GREAVES. 2. HAVELLS INDIA LTD. 3. PHILIPS (SIGNIFY INOVATION INDIA LTD) 4. ORIENT (CK BIRLA GROUP). 5. WIPRO

38	LED LIGHT FITTING – INDOOR & OUTDOOR	2418	1. CROMPTON GREAVES. 2. HAVELLS INDIA LTD. 3. PHILIPS (SIGNIFY INOVATION INDIA LTD) 4. ORIENT (CK BIRLA GROUP). 5. WIPRO 6. JAQUAR
39	WALL BRACKET LED TYPE LAMP	-	1. CROMPTON GREAVES. 2. HAVELLS INDIA LTD. 3. PHILIPS (SIGNIFY INOVATION INDIA LTD) 4. ORIENT (CK BIRLA GROUP). 5. WIPRO 6. JAQUAR
40	CFL LAMPS/ LED LAMP (p.f. above 085)	IS-3646-1 (1992)	1. CROMPTON GREAVES. 2. HAVELLS INDIA LTD. 3. PHILIPS (SIGNIFY INOVATION INDIA LTD) 4. ORIENT (CK BIRLA GROUP). 5. WIPRO 6. JAQUAR
41	Exhaust fans pvc/ Metal body	302-280	1. ORIENT (CK BIRLA GROUP). 2. CROMPTON GREAVES. 3. HAVELLS INDIA LTD.
42	Electric Call Bell	2268 1988	1. ANCHOR. 2. LEGRAND. 3. HAVELLS. 4. L&T 5. HPL
43	Wall mounted fan / air circulator/ ceiling fan	3212-1967	1. ORIENT (CK BIRLA GROUP). 2. CROMPTON GREAVES. 3. HAVELLS INDIA LTD.
44	LED TYPE TUBE LIGHT FITTINGS	-	1. CROMPTON GREAVES. 2. HAVELLS INDIA LTD. 3. PHILIPS (SIGNIFY INOVATION INDIA LTD) 4. ORIENT (CK BIRLA GROUP). 5. WIPRO 6. JAQUAR
45	Fan Regulator,(ELECTRONIC	11037 1984	1. LEGRAND 2. HONEYWELL 3. ABB 4. ANCHOR 5. HAVELLS
46	WATER HEATER(Geyser)	2082 1985 & TI 4	1. ORIENT (CK BIRLA GROUP). 2. CROMPTON GREAVES. 3. HAVELLS INDIA LTD.
47	MS Conduit	9537	1. MK INDIA. 2. PRECISION. 3. AKG. 4. JB CONDUITS
48	Battery Charger	-	1. SERVOCON

49	Battery	-	1. AMCO. 2. EXIDE. 3. AMARON. 4. HITACHI. 5. LUMINIOUS.
50	GI Octagonal Poles/ HIGH MAST		1. CROMPTON GREAVES. 2. PHILLIPS (SIGNIFY INOVATION INDIA LTD) 3. SURYA ROSHNI LTD
51	GI SWITCH BOX	IS-732/2019	ISI APPROVED
52	FAN BOX		ISI APPROVED
<b>Miscellaneous Items</b>			
1	Water Coolers	1479-1978	1. HAVELLS 2. CROMPTON
2	Rubber Mat (Electrical Insulating Mat) HT/LT 2 mm	4770	1. SUNITEX ENTERPRISES. 2. LAKSMI RUBBER. 3. DURATUF PRODUCT PVT. LTD. 4. GANPANTI ENTERPRISES. 5. SHIVA INDUSTRIES. 6. JOYTI RUBBER UDYOG.
3	UPS	-	1. EATON 2. SERVOCON 3. L&T 4. LEGRAND- NUMERIC
4	ACSR	398 Pt IV	1. SURYA INDUSTRIES. 2. SHARK STEEL. 3. BHARAT WIRE ROPES LIMITED. 4. SYSTEMATIC INDUSTRIES PVT LIMITED. 5. MICA INDUSTRIES LIMITED. 6. H.D. WIRES PVT LTD. AS PER UPCL.
5	Solar Water Heating System	BIS-12933	MNRE APPROVED
6	Lift, Elevators	-	1. KONE 2. ECE 3. OMEGA
7	Solar Power System, Solar lights, Solar Panels.		1. CROMPTON GREAVES. 2. PHILLIPS (SIGNIFY INOVATION INDIA LTD) 3. HPL 4. HAVELLS. MNRE APPROVED.
8	DIGITAL SERVO VOLTAGE STABILIZER UPTO 5000 KVA		1. SERVOKON SYSTEM LTD. 2. EATON
<b>AIR CONDITIONING</b>			
1	Split type AC	1391	1. HAVELLS - LLOYD 2. VOLTAS.
2	Package type AC/ Cassette AC	-	1. HAVELLS - LLOYD 2. VOLTAS.
3	Chilling Package Unit	-	1. HAVELLS - LLOYD 2. VOLTAS.



4	Pump Mono Block	1520-1972	1. CROMPTON GREAVES. 2. BCH 3. HAVELLS.
5	Butterfly Valve	781	1. FORTVALE. 2. APOLLO. 3. FESTO. 4. PARKER. 5. ROTEX. 6. KIRLOSKAR.
6	VRF Type AC		1. TOSHIBA. 2. DAIKIN. 3. GOODMAN. 4. BLUE STAR. 5. CARRIER CORPORATION. 6. VOLTAS. 7. HITACHI.

### **FIRE FIGHTING SYSTEM**

7	MS PIPES/G.I. PIPES	1239	TATA/JINDAL/SURYA HISSAR/PRAKASH/ OR EQUIVALENT.
8	GUNMETAL HYDRANT VALVE	5290	MINIMX /SUPEREX /OMEX/NEWAGE NEW AGE, G-TECH OR EQUIVALENT
9	BUTTERFLY VALVE	: 13095	ZOLOTO /KARTAR //OMEX/AUDCO FIREFOX ,G-TECH OR EQUIVALENT
10	FIRE HOSE CABINET		MINIMAX / OMEX/SUPEREX, G-TECH OR EQUIVALENT
11	FIRE EXTINGUISHER	15683 & ISO-9001, DGMS	MINIMAX //OMEX/CEASEFIRE, SUPEREX.OR EQUIVALENT
12	SHORT BRANCH PIPES		SUPEREX / OMEX/MINIMAX / NEWAGE OR EQUIVALENT
13	RRL HOSE PIPE		MINIMAX/OMEX/ NEWAGE /OMEX/ JAYASHREE OR EQUIVALENT
14	SLUICE VALVE/GATE VALVE/FOOT VALVE	780-1969 2906-1969	KIRLOSKAR, LEADER, L&T
15	NON RETURN VALVE	5312- 1979	KIRLOSKAR, LEADER, L&T
16	PUMP SETS/MONO BLOCK	-	KIRLOSKAR, CROMPTON, JYOTI, BEACON, MAXFLOW
17	CENTRIFGAL PUMPS	1710-1973	KIRLOSKAR, CROMPTON, BECON, KSB
18	SUBMERSIBLE PUMP	1520-1972	KSB, CROMPTON GREAVES, KIRLOSKAR, GRUNDFOS
19	SUBMERSIBLE CABLE	694	HAVELLS, BCH, RR KABEEL, FINOLEX
20	MOTOR STARTER	13947-4	L&T, HAVELLS, TELEMCHANIQUE AND CONTROL, BCH, CAPITAL
21	WATER LEVEL INDICATOR	-	AKASH, PHOTRON, PUMPUTER
22	SINGLE PHASE PREVENTOR / PHASE SEQUENCE CORRECTOR	-	AKASH, MINILILEC, TELEMCHANIC, L&T, HAVELLS, SINETRAC, ABB, CUTLER HAMMER(BCH)
23	LT CUBICAL PANEL/FEEDER PILLAR	5039 1983	AND MANUFACTURE APPROVED BY CPRI AND DESIGN AS PER IP-54& IS-8623
24	PUMP		KIRLOSKAR/ MATHER& PLATT/ GUNDFOSS/ CROMPTON
25	MOTOR		KIRLOSKAR/ABB/CROMPTON
26	DIESEL ENGINE		MAHINDRA / KIRLOSKAR / CUMMINS
27	CONTROL CABLE		POLYCAB, FINOLEX, HPL, RR KABEL, HEVELS

28	ADVANCED LIGHTING ARRESTER (ESE)		BAKIRAL, ABB.FRANKFIN
----	-------------------------------------	--	-----------------------

# Fire Alarm & Fire Hydrant Specification



# **Technical Specification**

## **FIRE DETECTION & ALARM SYSTEM**

The work shall be executed as per CPWD's General specifications Part V (Wet Riser and Sprinkler system for Fire Fighting Installation)-2006 Part VI – (fire Alarm system) IE Rules, Indian Standards amended upto date as per direction of Engineer Incharge.

### **1. GENERAL**

- 1.1 This specification outlines the requirements for Microprocessor based Fire Detection and Alarm System.
- 1.2 The work described in this specification consists of all labour, materials, equipment and services necessary and required to complete and test the automatic fire alarm detection system. Any material not specifically mention in this specification or not shown on drawings but required for proper performance and operation shall be furnished and installed to complete and operational system by approval of Engineer-in charge.
- 1.3 A microprocessor fire alarm and detection system includes control panel, detecting or initiating devices like manual pull stations, smoke and heat detectors, response indicator, indicating devices as sounders, bells, visual warning signals etc and wiring system connecting devices. Fire officer, Dehradun, Uttarakhand shall inspect the system and his approval is necessary.
- 1.4 The installation and locations of equipment and devices in the building shall be governed by the specifications and drawings, concerned code standard, regulation under fire act w.r.t actual site conditions, ambient factors affecting the equipment, and other operations in the vicinity. If any departure from the specifications or drawings is necessary, approval shall be obtained from the engineer-in-charge before work is started thereon.
- 1.5 The system and components used shall be of any firms of established reputation. They shall be MINIMAX, BOSCH, SYSTEM SENSOR, APOLLO. Any other manufacturer or its dealer similar to above reputed firms may get approval in Pre Bid Meeting after satisfying their quality & specifications etc.
- 1.6 All individual components and composite systems shall be designed for continuous operation without undue heating or change in rated values, and shall be properly fused.
- 1.7 All materials, devices, and equipment shall be compatible with the circuits or systems in which they are utilized.

### **2 CODES & STANDARDS**

- 2.1 The design, supply, installation and commissioning of the entire fire detection and alarm system shall confirm to IS:2189 for which the contractor should have the required certificate. The detectors shall confirm to relevant codes for Fire alarm System.
- 2.2 Wiring shall be done as per CPWD's specifications.

### **3 MANUALS AND DRAWING REQUIRED**

- 3.1 Drawings: Submit, on sheets not smaller than 8 ½ by 11 inches, identifying all symbols showing locations of devices & wiring.
- 3.2 Control panel interior wiring diagram.
- 3.3 Operations and Maintenance Manuals: Furnish for all system components.
- 3.4 Instruction Manuals
- 3.5 System Description

3.5.1 Detailed description of the control panel

## 4 **EQUIPMENTS & DEVICES**

### 4.1 **GENERAL**

The fire detection and alarm system shall be of high quality fast-acting electronic type. The FDA System & equipments shall be confirming to the relevant codes & standards and applicable requirements.

4.1.1 The fire detection and alarm system shall be designed to facilitate accurate identification of the source of heat/ smoke/fire in their early stages to minimize occurrences of false alarms due to faulty equipment, electrical transients, system faults etc.

4.1.2 The microprocessor system shall make the final decision on whether a fire or fault exists by comparing the sensed fire/fault patterns against all known fire and fault patterns held in it's memory.

4.1.3 All system components and devices shall be connected by zone circuits provided with each zone. Removal or disconnection of any component from the zone shall not affect the functioning and performance of those devices.

4.1.4 Facilities are provided to constantly monitor and check the following fault conditions:

- a) The power supply to the loop/s;
- b) For open-circuit, short-circuit, earth fault and any other fault condition in the loop wiring;
- c) For communication failure and errors in all cards.

4.1.5 All connecting devices i.e., Detectors, MPS's, Controller etc. shall be installed on the same zone.

4.1.6 In case of fire, fault or warning, the label of device sensing threshold shall appear on visual display unit of the panel.

4.1.7 Provision shall be done at the fire alarm control panel to silence the alarm sounders but the visual indication shall remain until the system is reset.

4.1.8 Facility to introduce/change delay periods in operating individual sounder/group of sounders, shall be possible to program for FACP preferably.

4.1.9 The main fire alarm control panel shall be located in one of the buildings and location will be decided in mutual coordination with the Engineer-in-charge or as per the drawings.

4.1.10 System must have facility of sensitivity adjustment of detecting devices preferably on FACP.

### 4.2 **SIREN**

Siren has to be installed in open and it should be weather proof. Range of the siren should be atleast 3 kms. It should be Operated by 220V 50V 50 Hz single phase motor.

### 4.3 **WIRING**

4.3.1 All wiring shall be done as per CPWD's specifications.

4.3.2 All cables used for connecting the system of two buildings should be armoured and should be laid as per CPWD's specifications.

### 4.4 **RESPONSE INDICATORS**

Lamp assembly consisting of lamp holder and lamp shall be suitable for mounting on walls, partition etc., Outside a cabin, and directly connected to the detector inside the cabin as per direction of Engineer-in-charge. In normal circumstances the lamp should not glow but in the event, the detector inside the cabin senses a fire, the lamp should glow steady glow.

### 4.5 **POWER SUPPLY**

- 4.5.1 The control panel shall derive 230/220 Volts power from main supply. A standby power supply shall be immediately available in the even of failure of normal supply and shall automatically be connected so as to maintain the equipment in condition such that fire alarm originating from the operation of Detector can be given. The standby battery as secondary supply shall be such that when charged by associated battery charging equipment it can operate independently for a period of 48 hours backup time. It shall have enough power supply to cope with additional load.
- 4.5.2 Necessary automatic changeover from normal to standby DC supply in case of main supply failure shall be provided by the Bidder.
- 4.5.3 In addition to the batteries, a battery charger suitable for operation on the auxiliary power available in the plant as specified above shall be supplied. The capacity of the charger shall be such that the same can boost charge of the battery (within 8 Hours ) while supplying the rated load of the fire detection and Alarm system. Isolator shall be provided to limit the voltage supplied to fire detection and alarm system to their rated values during he time of boost charging. The charger shall normally supply the battery trickle charging current and the DC load of the fire detection ad alarm system. In case the AC supply on the input side of the charger the necessary power for the complete fire detection and alarm system.
- 4.5.4 Visible and audible annunciation for troubles or failure in the power supply system like charger Failure”, Battery; Low Voltage”, etc. shall be provided.
- 4.5.5 Battery earth/fault indication/annunciation shall be included in the panel
- 4.5.6 Adequately rated batteries shall be connected via mains failure relay contact across 24 Volts regulated DC supply. In normal condition, battery shall be kept on constant trickle charge. Battery can be boost charged by manually operation trickle/boost toggle switch when battery low indication is observed on the control panel. In case of mains failure, battery shall automatically feed full supply load of the entire system consisting of fire alarm, and exit signs etc. Battery capacity shall fully meet the requirements of CL 5.2 IS 2189.

## 5 **COMMISSIONING AND REQUIRED TESTING**

- 5.1 The commissioning and acceptance tests shall be done apart from the standard or routine tests prescribed and normally conducted by the manufacturer/contractor and will be irrespective of the fact whether the same are covered by such tests or not.
- 5.2 Each zone shall be tested by attest fire or by a heat source, such as hair dryer or shielded heat lamp below any one detector selected arbitrarily and the time required for detection shall be noted.
- 5.3 Each sounder circuit shall be energized separately and the sound level reading taken to check for conformity with the minimum standards.
- 5.4 Open circuit and removal of detector for each detection circuit shall be tested.
- 5.5 Short circuit for each detection circuit will be tested.
- 5.6 Mains failure performance.
- 5.7 Battery disconnection test.
- 5.8 Open circuit of each sounder circuit to be basted.
- 5.9 Short circuit of each sounder circuit to be tested.
- 5.10 The results of the above tests either by fault warning of fire alarm shall be recorded in the log books which will be signed both by the contractor and the employer.
- 5.11 Any other required by inspecting authority or Engineer-in-Charge.

## 6. **Fire Fighting System**

- 6.1 Following types of water based fixed fire fighting installations are normally provided in buildings.
  - (i) Wet Riser.

- (ii) Down Corner.
  - (iii) Wet Riser cum Down Corner.
  - (iv) Automatic Sprinkler.
- 6.2 In all the above systems, lines are laid in and/or around the building and permanently charged with water form a pressurized supply. In a building any one system or a combination may be provided as per NBC Code of India (Part - IV).
- 6.3 Municipal Regulation of the city will also be taken in to consideration while selecting and designing fire Fighting system for a building.

## 7 SYSTEM COMPONENT

Besides architectural and building provision such as under ground tank, pump houses, terrace tank, shafts for installation of internal hydrants, etc.

### Wet Riser cum Down Comer

- 7.1 The operating pressure of individual hydrant shall be 3.5 Kg/cm<sup>2</sup>. At terrace level hydrant, minimum 3.5 Kg/cm<sup>2</sup> pressure shall be maintained.
- 7.1(i) The pipe line will be designed in such a way that it should be possible to get discharge at any location. Design parameters shall be as under:-
- (i) Maximum flow velocity - 2.5 mps.
  - (ii) Maximum friction - 5m. per 100 m. run
- 7.2 Main Fire Pumps (Both electrical as well as diesel) shall be selected for.
- (i) Discharge – 2280 lpm
  - (ii) Head – 35 m + Height of terrace level hydrant above pump level.

### 7.3 Terrace Pump

- (i) Discharge – 450 lpm
- (ii) Head – 20 m + 6% of the maximum length of pipe from terrace pump to any hydrant at terrace level

### 7.4 Jockey Pump

- (i) Discharge – 200 lpm to 300 lpm
- (ii) Head – 35 m + Height of terrace level hydrant above pump level

## 8 Internal Hydrant

Every riser will be provided with the following at every floor including terrace and basement over and above sprinkler system.

- (i) Single headed out let - 2 Nos.
  - (ii) First Aid Hose Reel - 1 No.
- Length of pipe shall be such that nozzle

of the hose can be taken into every room and

within hose can be taken into every room and within 6 mtr of any part of the rooms keeping in view layout and obstruction.

- (iii) Hose pipe 63 mm dia 15 m long with male and female coupling at both ends. - 2 Nos.
- (iv) Branch pipe 63 mm. dia with 20 mm. (nominal internal diameter)  
Nozzle and suitable for instantaneous - 1 No.

## 9 **Yard Hydrant (External Hydrant)**

- 9.1 For fighting fire from outside the building, yard hydrants are provided around the building and in the closed court yard. For connecting yard hydrants a ring of pipe shall be laid underground around the building at a minimum distance of 2 m. from the face of the building. All internal hydrants risers shall be connected with this ring.

Yard hydrants shall be located at a minimum distance of 2 m. but not more than 15 m from the building face. The yard hydrants shall be accessible and should normally be provided near boundary wall/along road. While locating yard hydrants it should be ensured that same do not become hindrance in vehicular movement or entrance to the building. Yard hydrants, should be located around the building in such a way that it should be possible to fight fire on any face of the building from the nearest hydrant. A distance of 45m. from hydrant to hydrant will be adequate.

9. **Air Vessel:** To counteract the water hammer effect, air vessels shall be provided one at top of each riser and shall be fabricated out of 8mm. thick M.S. sheet. The ends shall be dished. This shall be of 200 mm.dia, 1.2 m high and installed vertically on suitable legs. The legs shall be provided with M.S. Plated of size 75mm x 75mm x 5mm at the bottom so that the legs do not puncture the roof. The legs shall be grouted in CC foundation. Flange connection shall be provided for connection with wet riser pipe. Air release valve and pressure gauge with shut off valve shall be provided. The air vessel shall be tested at 25 kg/cm<sup>2</sup> pressure before installation.
11. **Orifice Plate:** To reduce pressure on individual hydrant to operating pressure of 3.5kg/cm<sup>2</sup>, orifice plate shall be provided before connection of hydrant.
12. **Alarm:-** To indicate the flow of water in the system, turbine type alarm shall be provided out side the pump house in the main line before any connection is taken. The alarm will indicate the healthiness of the system and shall not be silenced till the main fire pump is in operation.
13. **Control system:-**
- 13.1 The system shall be designed for operation automatically so that as and when water is drawn from the system through any hydrant, the pumps will operate automatically and feed water in to the system. However once a fire pump start working, it will be stopped only manually (except jockey pump) or on account of any fault or non availability of power supply to electrical pumps or low water level in UG/Terrace tank.



Facility shall also be provided for manual operation. A selector switch of auto/manual selection shall be provided in each pump.

- 13.2 The control system shall be designed to provide the flowing sequence of operation.
- (a) The pressurization Pump shall maintain pressure in the system and shall operate only on account of slow pressure loss. In case of sudden pressure loss the pressurization Pump shall not operate. The pump shall start when the water pressure in the system falls to a pre-set value (about 0.35kg./cm<sup>2</sup> below normal system pressure) and shut down when the system pressure reached the set value. Both limits shall be adjustable.
  - (b) Main electric Fire pump shall operate on account of sudden pressure loss. So long as Main electric Fire Pump is working, other Fire Pumps will not operate. The pump shall start when the water pressure falls to a pre-set value in the system (about 1 kg./cm<sup>2</sup>)
  - (c) The diesel Fire pump will start on sudden pressure loss, only in case supply to Main electric Fire pump is not available or within a pre-set time the Main Electric Fire Pump fails to start or fails during operation. No other pump will be working when diesel Engine Fire Pump is in operation. No other pump will be working when Diesel Engine Fire Pump is in operation. Audio-Visual Alarm shall be available to indicate failure of Main electric Fire Pump.
  - (d) A three attempts starting facility will be provided for diesel pump.
  - (e) If within a pre-set time, the standby pump also fails to start or fails to develop pressure, the standby pump shall also be shut down and locked out. An audio visual alarm indication shall be given at the control panel.
  - (f) The Terrace pumps will start on sudden loss of pressure only when both the Fire Pumps have either failed to start or exhausted water.
  - (g) Only one pump will be working at a time. In manual mode more than one pump can be started.
  - (h) Water level in UG and terrace tanks shall be monitored and in case of low water level, pumps connected with the tank shall not operate (even on manual mode) or stop operation as the case may be. An audio-visual alarm shall be given at the control panel.
- 13.3 **Control system:-** The starting of terrace pump shall be automatic i.e. with the opening of any hydrant valve or hose reel on any floor, the pump will start automatically with fall in line pressure. In addition start/stop push buttons shall be provided at ground floor near internal hydrant for starting the pump manually. Where fire control room has been provided, remote operation of terrace pump may be done from fire control room in place of internal hydrant. The control panel for terrace pumps shall be provided near the pumps in suitable enclosure to avoid unauthorized operation.

#### **13.4 Automatic Sprinkler:-**

- 13.4(i) In addition to all provisions of wet riser and down comer system automatic sprinkler system, water lines of various size are laid throughout the area to be protected and

sprinkler heads are provided at regular interval so that water from sprinkler head cover the entire area under fire.

- 13.4 (ii) Sprinkler has two functions to perform i.e. to detect fire and then to provide adequate distribution of water to control or extinguish it. Sprinkler heads operate at predetermined temperature to discharge water over the affected area below. Only those sprinkler heads operate which are in the vicinity of fire i.e. those which become sufficiently heated.
- 13.4 (iii) Lines for sprinklers may be separate or common with wet riser system depending upon type of building.
- 13.4 (iv) The area to be protected by sprinkler is divided in to various zones. For detecting operation of sprinkler in a zone, flow switches are provided which are wired to an annunciation panel installed in the fire control Room. In the event of operation of sprinkler (s) in an affected area, the annunciation panel will give audio-visual alarm and indicate the affected zone. This arrangement will be independent of fire alarm system.
- 13.4(v) The sprinkler shall be installed only where there is no danger of freezing of water in the pipes at any time.
- 13.4 (vi) Temperature rating of a sprinkler should not be less than 30<sup>0</sup> C mother than the highest anticipated temperature of the location of installation. Under glazed roofs or where there are roof sheets of PVC or similar plastic material, sprinkler shall be rated 79<sup>0</sup> C to 100<sup>0</sup> C.
- 13.4 (vii) Electrical operated alarm shall be provided for indication of operation of sprinkler in an area. Water flow switches shall be installed in main distribution pipes which shall be wired to sprinkler annunciation panel. In the event of operation of a sprinkler, the flow switch will operate and give signal to the annunciation panel to indicate operation of sprinkler in the area. This will initiate an electrically operated alarm. The system shall be independent of fire alarm system.

#### 14. **Fire Pump:**

Scope:-

The General requirement of water pump for main fire pump, jockey pump and terrace pump.

Type:-

The pump shall be centrifugal type direct driven with a 3 phase, 415 V + 10%, 50 Hz A.C. motor. The standby fire pump shall be driven by diesel engine. The pumps may be either of horizontal split casing (HSC) type with operating speed not exceeding 1500rpm. , or solid casing with operating speed not exceeding 300 rpm. As specified in the tender documents.

**Installation:-**

- (i) The pump and motor/engine assemble shall be mounted and arranged for ease of maintenance and to prevent transmission of vibration and noise to the building structure or to the pipe work.

- (ii) The Pump and motor/engine assembly shall be installed on suitable RCC foundation. The length and width of the foundation shall be such that 100mm. space is left all around the base frame. The height of foundation shall be so decided that the total weight of foundation block is 1.5 times the operating weight of the pump assembly. The foundation shall be isolated from the floor by vibration isolating pads. Angle iron frame of size 35mm x 35mm x 3mm shall be provided on the top edges of the foundation
- (iii) More than one pump and motor assembly shall not be installed on a single base or cement concrete block.
- (iv) the suction/discharge pipe shall be independently supported and their weight shall not be transferred to the pump. It should be possible to disconnect any pump for repairs without disturbing the connecting pipe line.
- (v) A minimum clearance of 1 m. around the main pumps shall be provided. For jockey pump- clearance of 75 cm. shall be adequate.
- (vi) Sufficient space is to be left front for the radiator of diesel engine for free discharge of hot air. Arrangement for discharging hot air to out side the pump house shall be provided so that hot air does not stagnate in the pump house.

## 15. Diesel Engine for fire pump

### 15.1 Scope

The requirements of diesel engine for main fire pump to act as standby.

### 15.2 General

The diesel engine shall be suitable for automatic operation complete with necessary automatic starting gear, battery system and shall be complete with all accessories. Both engine and pump shall be assembled on a common bed place, fabricated from mild steel channel.

### 15.3 Diesel Engine

- (i) Environmental Condition:- The engine shall be suitable to operate under the condition of environment at site.
- (ii) **Engine Rating:-** The engine shall be multi cylinder/vertical 4 stroke cycle, water cooled, developing suitable HP at the operating speed specified to drive the fire pump. Continuous capacity available for the load shall be exclusive of the power requirement of auxiliaries of the diesel engine, and after correction for altitude, ambient temperature and humidity for specified environment condition. The engine rating shall be suitable to drive the pump at 150 percent of its rated discharge with at least 65 percent of rated head. The engine shall have 10% overload capacity for one hour in any period of 12 hours continuous run.

The engine shall be suitable for cold starting for which suitable heaters shall be provided in lubricating oil.

The engine shall develop full load within 15 seconds from the receipt of signal to start. The diesel engine shall conform to BS 649/IS 1601/IS 10002, amended upto date.

#### 15.4 **Cooling system:**

The engine shall be radiator water cooled. The radiator assembly shall be mounted on the engine. The radiator assembly shall be mounted on the engine. The radiator fan shall be driven by the engine as its auxiliary with multiple fan belts. When half the belts are broken, the remaining belts shall be capable of driving the fan. Cooling water shall be circulated by means of an auxiliary pump of suitable capacity driven by the engine in a closed circuit.

#### 15.5 **Fuel System:**

The Fuel system shall be gravity fed from the fuel tank to the engine driven fuel pump. The engine fuel tank shall be mounted either adjacent to the engine or suitable wall mounted on brackets. The fuel filter shall be suitable located to permit easy servicing.

15.6 **Exhaust System-** The exhaust system shall be complete with residential silencer suitable for outdoor installation and silencer piping shall be extended up to 1 m, outside pump house duly insulated with 50mm thick glass wool and 1.0 mm. thick aluminum sheet cladding.

15.7 **Engine shut down mechanism-** This shall be manually operated and shall return automatically to the starting position after use.

15.8 **Governing system:** The engine shall be provided with an adjustable governor to control the engine speed within 5% of its rated speed under all conditions of load upto full load. The governor shall be set to maintain rated pump speed at maximum pump load.

15.9 **Engine Protection devices:** Following engine protection and automatic shut down facilities shall be provided:

- (i) Low lub, oil pressure;
- (ii) High cooling water temperature.
- (iii) High lub. Oil temperature.
- (iv) Over speed shut down.

15.10 **Anti vibration mounting-** Suitable vibration mounting duly approved by engineer-in-charge shall be employed for mounting the unit so as to minimize transmission of vibration to the structure.

15.11 **Battery Charger-** Necessary float and boost charger shall be incorporated in the control section of power and control panel, to keep the battery under trim condition. Voltmeter to indicated the state of charge of the batteries shall be provided.

### 16. Pipe work

Requirement of pipe work in fire fighting installation

#### 16.1 Pipes shall be of the following materials

- (i) mild steel heavy class (C-Class) conforming to IS:1239 for size upto 150mm

- (b) Welded black steel pipe, class-2, conforming to IS: 3589, for sizes greater than 150 mm. These pipes shall be factory rolled and fabricated from minimum 6 mm thick M.S. sheet for pipes upto 350 mm dia and from minimum 7 mm thick M.S. sheet for pipes of 400 mm dia and above.
- (c) Cast iron double flanged class- 'A' conforming to IS: 1536 or IS: 1537 (to be provided only in under ground application).
- (d) GI pipe medium class (B-Class) conforming to IS: 1239
- (ii) Cadmium plated steel nuts/bolts/washers shall be used.

## **17. VALVES**

Sluice valve conforming to IS:780 or butterfly valve conforming to IS:13095 shall be provided. All valves shall be suitable to with-stand the pressure in the system and rating shall be PN. 1.6. All valves shall be right handed (i.e. handle or key shall be rotated clock wise to close the valve), the direction of opening and closing shall be marked and an open/shunt indicator fitted.

## **18. STRAINERS**

Stainless steel strainers shall have minimum 1 mm thick screen with 3 mm perforations. Strainers shall be provided with flanges.

## **19. PRESSURE TESTING**

- a. All piping shall be tested to hydrostatic test pressure of at least one and half times the maximum operating pressure, but not less than 10 kg./sq.cm for a period not less than 24 hours. All leaks and defects in joints revealed during the testing shall be rectified to the satisfaction of the Engineer-in-charge.
- b. Piping repaired subsequent to the above pressure test shall be re-tested in the same manner.
- c. System may be tested in sections and such sections shall be securely capped.
- d. Pressure gauges may be capped off during pressure testing of the installation.

## **28. PIPE SUPPORTS**

For installing pipes vertically or horizontally inside the building standard pipe supports of reputed make shall be used. Following supports shall be used.

- (i) Split pipe support clamps with rubber lining for vertical, horizontal and floor hanging.
- (ii) Clevis Hangers for horizontal supports to adjust varying heights.
- (iii) Sprinkler Hangers for horizontal supports for pipes from 15mm dia to 150mm dia

Fasteners and fully threaded rods shall be used for installing the pipe supports. The sizes of pipe supports and installation shall be in accordance with manufacturers recommendations. Some of the typical supports are shown in the Figure-9

For pipes of size 100 mm and above, with the prior approval of Engineer-in-Charge, 'U'Clamp with dash fastner may be used for supporting horizontal pipe from ceiling.

## **29. Anti-corrosive protection on under ground pipe**

Corrosion protection tape shall be wrapped on M.S. pipes to be buried in ground. This corrosion protection tape shall comprise of coal tar/asphalt component supported on fabric or organic or inorganic fiber and minimum 4 mm. thick and conform to requirement of IS: 102221-code of practice for coating and wrapping of under ground mild steel pipeline. Before application of corrosion protection tape all foreign matter on pipe shall be removed with the help of wire brush and suitable primer shall be applied over the pipe thereafter. The Primer shall be allowed to dry until the solvent evaporates and the surface becomes tacky. Both primer and tape shall be furnished by the same manufacturer. Corrosion protection tape shall then be wound around the pipe in spiral fashion and bounded completely to the pipe. There shall be no air pocket or bubble beneath the tape. The overlaps shall be 15mm. and 250mm. shall be left uncoated on either end of pipe to permit installation and welding. This area shall be coated insitu after the pipe line is installed. The tapes shall be wrapped in accordance with the manufacturer's recommendation. If application is done in cold weather, the surface of the pipe shall be pre-heated until it is warm to touch and traces of moisture are removed and then primer shall be applied and allowed to dry.

## **30. First Aid Hose Reel**

First Aid Hose Reel is meant for delivering small quantity of water in early stage of fire and can be operated even by untrained personnel, and thus provides a most effective fire fighting facility. It consists of a length of 20mm (nominal internal) diameter hose tubing warped around a reel with water inlet pipe, stop valve and shut off nozzle. The entire assembly is mounted on a wall bracket and can swing 180 degree. The water inlet is connected to the riser pipe by means of 37 mm socket and valve. The hose tube can be pulled out easily for the purpose of discharge of water on fire.

### **22.1 Delivery Hose coupling's**

The delivery hose couplings consists of male half coupling and female half coupling. Groves are provided on outer side on both coupling of binding hose pipe with wires. In female coupling spring loaded cam tooth is provided for holding male half coupling in position. Male half coupling and female half coupling are provided on both side (i.e. on one side male and on other side female) of hose pipes. Two or more pipes can be joined together with the help of these couplings instantaneously.

### **22.2 Branch pipe and Nozzle:**

Branch pipes with nozzle are mounted at the end of hose pipe. Branch pipe is properly finished and free from sharp edges. During operation, a fireman has to hold the branch pipe. One end of branch pipe is fixed with hose coupling and the other end is threaded to fit the nozzle.

Nozzle is tapered pipe with one end threaded internally which is fixed on branch pipe. The size of other end i.e. nozzle shall be 20 mm. ( nominal internal diameter)

### 22.3 Material of construction

- (i) Copper Alloy
- (ii) Aluminum Alloy

### 22.4 Hose Pipes

- (i) Hose pipes shall be fiber lined woven jacketed and 63mm in diameter. They shall conform to type A (Re- inforced rubber lined) of IS: 636. They shall be flexible and capable of being rolled. Length of Hose pipe will be 15 m.
- (ii) The hose pipe be complete with male and female coupling at the ends.

**31.** Besides keeping hose pipe with internal hydrant and yard hydrant, spare hose pipes alongwith branch pipes shall be kept in fire control room/pump room.

**32. BRANCH PIPE AND NOZZLE:** Branch pipes with nozzle are mounted at the end of hose pipe. Branch pipe is properly finished and free from sharp edges. During operation, a fireman has to hold the branch pipe. One end of branch pipe is fixed with hose coupling and the other end is threaded to fit the nozzle.

Nozzle is tapered pipe with one end threaded internally which is fixed on branch pipe. The size of other end i.e. nozzle shall be 20mm (nominal internal diameter)

### **33. FIRE SERVICE INLET AND FIRE SERVICE CONNECTION**

25.1 These are provided for connection of fire service hose pipes for either directly pressuring the system with their pumps of filling water in the tank from a distance. In the first case non return valve with butterfly valve shall be provided for holding water pressure. Fire service inlet shall be provided with each wet riser/down comer and the ring main. 150 mm dia pipe and located in MS Box made of 2mm thick mild steel sheet with openable glass cover.

### **34. POWER CABLING**

(i) Unless otherwise specified, the power cables shall be XLPE insulated, PVC outer sheathed aluminium conductor, armoured cable 1100 V grade. The power cables shall be of 2 core for single phase, 4 core for sizes upto and including 25 Sq. mm 3-1/2 core for sizes higher than 25 sq.mm for phase.

Alternatively, XLPE/PVC insulated copper cable (single core/multicore unarmoured) of graded 1100 V shall be used.

- (ii) Power cables shall be of sizes to meet the starting and running current of motors fed and shall be as approved by the Engineer-in-charge, after taking into consideration the load, the length of cabling.
- (iii) Cables shall be laid in suitable metallic trays suspended from ceiling, or mounted on walls. Cable ducts shall not be provided in pump rooms. Cable trays shall be of perforated steel sheet with adequate structural strength and rigidity.

Necessary supports and suspenders for cable trays shall be provided by the contractor as required.

### **35. CONTROL WIRING**

- (i) Control wiring shall be done using ISI marked PVC insulated and PVC sheathed, 2.5 sq.mm, 250 V grade, unarmoured multi-core copper conductor cable. The control cable shall also be laid in the same manner as power cable.
- (ii) The number and size of the control cables shall be such as to suit the control system design adopted by the contractor.
- (iii) Runs of control wires within the switchboard shall be neatly bunched and suitably supported/clamped. Means shall be provide for easy identification of the control wires.
- (iv) Control wiring shall correspond to the circuitry/sequence of operations and interlocks approved by Engineer-in-Charge.

### **36. EARTHING**

- (i) Provision of earth electrodes and the type of earthing shall be as specified in the tender specifications.
- (ii) The earth work shall be carried out inconformity with CPWD Specifications for Electrical works (Part-1), Internal 2005
- (iii) Metallic body of all motors, medium voltage equipments and switch boards shall be connected by two separate and distinct earth conductors to the earth stations of the installation. Looping of such body earth conductors is acceptable from one equipment, or switch board to another.
- (iv) The size of earth conductors for body earthing of equipments shall be 2 Nos. 6 mm dia copper wire/2 Nos. 25 x 3 mm G.I. strip.
- (v) Armouring of cables shall be connected to the body of the equipments/switch board at both the ends. Compression type glands shall be used for all such terminations in the case of PVC cables.

### **37. Final Inspection and Testing**

Final Inspection and testing will be done by the Engineer-in-charge or his representative as per details norms. The installation will be offered for inspection by local bodies (Chief Fire Officer). The contractor or his representative shall attend such inspection of the Chief Fire Officer, extend all test facilities as are considered necessary, rectify and comply with all observations of the Chief Fire Officer which are part of the agreement and arrange for obtaining necessary clearance certificate in favour of the department. In case the contractor fails to attend the inspection and make desired facilities available during inspection, the department reserves the right to provide the same at the risk and cost of the contractor and impose penalty for the same. The installation will be accepted by the department only after receiving clearance from Chief Fire Officer for the work executed by the contractor under the agreement.

### **38. Safety Measures**



All equipments shall incorporate suitable safety provisions to ensure safety to the operating personnel at all times. The initial and final inspection reports shall bring out explicitly the safety provisions incorporated in each equipment.

**39. Guarantee**

- (i) The contractor shall guarantee the complete system to provide the specified flow and pressure under all conditions and outlets.
- (ii) All equipments shall be guaranteed for a period of 12 months from the date of acceptance and taking over of the installation by the Department against unsatisfactory performance and/or breakdown due to defective design, material, manufacture, workmanship or installation. The equipment or competent or any part thereof so found defective during the guarantee period shall be repaired or replaced free of cost to the satisfaction of the Engineer-In-Charge. In case it is felt by the department that undue delay is being caused by the contractor in doing this, the same will be got done

# Electrification Specification

# Technical Specification

## Wiring

### Scope:

The scope of this section covers the supply, erection, testing and commissioning of conduits & wiring for lighting and power. Wiring shall be carried out in accordance with relevant I.S. rules and regulations.

### System of wiring:

All lights and power wiring shall be carried out in surface conduits or recess wiring in conduits or floor ducts as specified in the BOQ.

I.E.E. regulations shall be applicable for all material and workmanship.

The wiring to be carried out in such a manner that specified 'Power' wiring shall be kept separate and distinct from 'Lighting' wiring. The wiring shall be done on the distribution system with main and branch distribution boards at convenient physical and electrical centers as shown in drawings. All conductors shall be run as far as possible along the walls and ceiling and above false ceiling so as it can be easily accessible and capable of being thoroughly inspected. In all types of wiring, due consideration shall be given for neatness and good appearance.

The balancing of load in three wire or poly phases installations shall be arranged before hand to the satisfaction of Engineer-in-charge. Circuits on opposite side of a three wire system or on different phase of poly phase system shall be kept apart at a minimum distance of 2m (6.6.ft) unless they are enclosed in earthed metal casing suitably marked to indicate the risk of dangerous shock due to voltage between the conductors contained in them. In large or important areas, light and socket outlet points shall be distributed over more than one circuit as directed.

Medium pressure wiring and associated apparatus shall comply in all respects with the requirements of IEE rules.

No wiring shall be carried out until the appropriate tests required in Section "Inspection and Testing" have been done and the Engineer-in-Charge has given his clearance for wiring to commence.

At expansion joints, adequate slack shall be left in the cables.

Where conduits are installed for wiring by others, a draw wire shall be provided between each draw-in position.

Cables forming part of communication circuits shall have identification sleeves at their terminations. Identification shall be consistent with the relevant wiring diagrams.

### Joints & Looping Back:

The wiring shall be done in a 'looping System'. Phase or live conductors shall be looped at the switch box and neutral/earth conductor can be looped either from the light, fan or socket outlet.

No bare or twist joints shall be made at intermediate points in the through run of cables, unless the length of final sub circuit or sub-main or main is more than the length of the standard coil given by the manufacturer of the cable.

Termination of multistrand conductors shall be done using suitable crimping type thimbles.

## **GI Conduits and Conduit Accessories**

All rigid conduit pipes shall be of GI and be ISI marked. The wall thickness shall be not less than 1.6mm (16 SWG) for conduits upto 32 mm dia and not less than 2mm (14 SWG) for conduits above 32 mm dia. These shall be solid drawn or reamed by welding, and finished with galvanized or stove enameled surface.

The maximum number of PVC insulated cables conforming to IS : 694-1990 that can be drawn in one conduit is given size wise in Table-I and the number of cables per conduit shall not be exceeded. Conduit sizes shall be selected accordingly in each run. No steel conduit less than 20mm in diameter shall be used.

The conduit wiring system shall be complete in all respects including their accessories.

All conduit accessories shall be of threaded type, and under no circumstances pin grip type or clamp grip type accessories shall be used. Bends, couplers etc. shall be solid type in recessed type of works and may be solid or inspection type as required, in surface type of works. Saddles for surface conduit work on wall shall not be less than 0.55 mm (24 guage) for conduits upto 25 mm dia and not less than 0.9 mm (20 guage) for larger diameter (as per Table-II). The corresponding widths shall be 19 mm & 25 mm.

Unless otherwise indicated, protection against corrosion of conduits and conduit fittings for general use inside buildings shall be of Class 2.

Adaptable and circular conduit boxes with their covers shall provide a minimum degree of protection of IP41 when used inside building and IP44 when used outside buildings or at other locations as indicated.

When conduit boxes are installed flush with the building fabric, overlapping covers shall be fitted.

Flexible steel conduit for general use inside buildings shall be of type A with protection against corrosion equivalent to Class 2. Adaptors shall be of solid type.

Unless otherwise indicated, accessory boxes used with steel conduit shall be made of metal.

Accessory boxes shall be suitable for flush or surface mounting, as indicated. Unless otherwise indicated, metal boxes for general use inside buildings shall be of steel of medium category against corrosion.

Accessory boxes shall be of adequate depth to accommodate the accessories without causing compression of the cables. Generally boxes shall be 75 mm deep, but for lighting switches installed flush in plaster finish with multi-cored sheathed cables, 65 mm depth boxes may be used.

Earthing terminals shall be fixed inside each accessory box and on the grids of grid switches. The earthing terminal of each grid shall be connected by a separate protective conductors to the earthing terminal of the box.

Front plates of accessories shall be of material and finish as indicated, but generally finish of various types of accessories in the same area shall match. For flush mounting, plates shall overlap the boxes. For surface mounting, plate shall match the profile of box, without overlap.

Where pilot lamps are required, they shall comprise a neon lamp with resistor and a red coloured lens, unless otherwise indicated.

Accessories with their boxes and front plates shall provide a minimum degree of protection of IP41 when used inside buildings and IP54 when used outside buildings or at other locations where indicated.

Accessory boxes shall be fixed to the fabric of building, independent of connecting cables or conduits. Where the accessories have a minimum degree of protection of IP54, the fixings shall not reduce that protection.

### **Installation: Common for Recessed and Surface Conduit Work**

#### **Conduit Joints**

- a) The conduit work of each circuit or section shall be completed before the cables are drawn in.
- b) Conduit pipes shall be joined by means of screwed couplers and screwed accessories only. Threads on conduit pipes in all cases shall be between 13mm to 19mm long, sufficient to accommodate pipes to full threaded portion of couplers or accessories.
- c) Cut ends of conduit pipes shall have no sharp edges, nor any burrs left to avoid damage to the insulation of the conductors while pulling them through such pipes.
- d) The Engineer-in-charge, with a view to ensuring that the above provision has been carried out, may require that the separate lengths of conduit etc. after they have been prepared shall be submitted for inspection before being fixed.
- e) No bare threaded portion of conduit pipe shall be allowed unless such bare threaded portion is treated with anti corrosive preservative or covered with approved plastic compound.

#### **Bends in Conduits**

- a) All necessary bends in the system, including diversion, shall be done either by neatly bending the pipes without cracking with a bending radius of not less than 7.5 cm, or alternatively, by inserting suitable solid or inspection type normal bends, elbows or similar fittings, or by fixing cast iron inspection boxes, whichever is most suitable.
- b) No length of conduit shall have more than the equivalent of four quarter bends from outlet to outlet.
- c) Conduit fittings shall be avoided as far as possible on conduit system exposed to weather. Where necessary, solid type fittings shall be used.

#### **Other Requirements**

- a) If the protective finish of any material has been damaged, those materials shall either not be used or any remedial work shall be approved by the Engineer-in-Charge before use. Conduits shall be clean and free from oil.
- b) Steel Conduits shall be connected by means of a coupler and an externally screwed bush. Bushes shall be tightened by using spanners. Pliers and toothed wrenches shall not be used.
- c) Where a terminal block is to be accommodated in a circular conduit box, an extension ring shall be fitted to the box, of sufficient depth to ensure adequate space for the terminal block and cables.
- d) The length of thread on the ends of steel conduits shall match that in the conduit fittings or equipment and exposed threads will not be permitted. Running couplings with backnuts may be used with conduit having Class 2 protection, but where the protection is Class 4 only, manufactured running joints will be accepted. Exposed thread on running couplings shall be given a coat of zinc-paint.
- e) Conduit shall be cold bent on site with a suitable bending tool and sand filling, without deforming its cross section.
- f) Draw in conduit boxes shall be incorporated at intervals not exceeding the following:

Straight run	10 m;
Run with one or two bends	10 m;
Run with three bends	5 m;
Run with four bends	5 m;

- g) Unless otherwise indicated, conduit buried in concrete shall have at least 30mm depth of cover; it shall be securely fixed to prevent movement during pouring and vibrating of the concrete. Conduit in plaster shall have at least 5 mm depth of cover.
- h) Where conduits cross expansion and settlement joints occur in the building structure, suitable provision shall be made to allow for movement of the structure. The Contractor shall submit his proposals for the approval of Engineer-in-Charge.
- i) Where conduit passes through an external wall, a conduit box shall be fitted on the inside of the wall and after wiring, filled with an inert permanently plastic compound having a high insulation value.
- j) Conduit shall be installed in screeds only where indicated or after receipt of the Engineer-in-Charge's approval. Conduit boxes in floors, other than for- agreed outlets will not be permitted.
- k) Open ends of conduit shall be temporarily plugged immediately after installation to prevent ingress of water and solid materials.
- l) Method to be used for forming fire barriers at fire resistant structural elements such as floors and walls shall be submitted for the Engineer-in-Charge's approval.
- m) Installed conduits shall be cleaned internally with a swab before cables are drawn-in.
- n) If the protective finish of conduit is damaged after fixing, the damage shall be made good in a manner approved by Engineer-in-Charge.

#### **Installation-Additional Requirements for Surface Conduit Work**

##### **Fixing conduit on surface**

- a) Conduit pipes shall be fixed by saddles, secured to suitable approved plugs with screws in an approved manner at an interval of not more than one metre, but on either side of the couplers or bends or similar fittings, saddles shall be fixed at a distance of 30 cm from the center of such fittings. The minimum width and thickness of the ordinary clips or the girder clips for different sizes of conduits shall be as given in Table-II. Where conduit pipes are to be laid along the trusses, steel joists etc. the same shall be secured by means of saddles clips or clamps as required by the Engineer in charge.
- b) In long distance straight run of conduit, inspection type couplers at reasonable intervals shall be provided, or running threads with couplers and jam nuts shall be provided.

#### **Installation-Additional Requirements for Recessed Conduit Work**

##### **Making Chase**

- a) The Chase in the wall shall be neatly made, and of ample dimensions to permit the conduit to be fixed in the manner desired.
- b) In the case of buildings under construction, the conduits shall be buried in the wall before plastering, and shall be finished neatly after erection of conduit.
- c) In case of exposed brick/ rubble masonry work, special care shall be taken to fix the conduit and accessories in position along-with the building work.

##### **Fixing Conduits in Chase**

- a) The conduit pipe shall be fixed by means of staples, j-hooks, or by means of saddles, not more than 60 cm apart, or by any other approved means of fixing.
- b) All threaded joints of conduit pipes shall be treated with some approved preservative compound to secure protection against rust.

#### **Fixing Conduit in RCC work**

- a) The conduit pipes shall be laid in position and fixed to the steel reinforcement bars by steel binding wires before the concreting is done. The conduit pipes shall be fixed firmly to the steel reinforcement bars to avoid their dislocation during pouring of cement concrete and subsequent tamping of the same.
- b) Fixing of standard bends or elbows shall be avoided as far as practicable, and all curves shall be maintained by bending the conduit pipe itself with a long radius which will permit easy drawing in of conductors.
- c) Location of inspection/ junction boxes in RCC work should be identified by suitable means to avoid unnecessary chipping of the RCC slab subsequently to locate these boxes.

#### **Fixing Inspection Boxes**

- a) Suitable inspection boxes to the minimum requirement shall be provided to permit inspection, and to facilitate replacement of wires, if necessary.
- b) These shall be mounted flush with the wall or ceiling concrete. Minimum 65 mm depth junction boxes shall be used in roof slabs and the depth of the boxes in other places shall be per IS: 2667-1977.
- c) Suitable ventilating holes shall be provided in the inspection box covers if directed.

#### **PVC Conduit and Conduit Accessories:**

All non-metallic conduit pipes and accessories shall be of suitable material complying with IS:2509-1973 and IS:3419-1989 for rigid conduits and IS:9537-2000 for flexible conduits. The interior of the conduits shall be free from obstructions. The rigid conduit pipes shall be ISI marked.

The conduits shall be circular in cross-section. The conduits shall be designated by their nominal outside diameter. The dimensional details of rigid non-metallic conduits are given in Table-III.

No non-metallic conduit less than 20 mm in diameter shall be used.

The conduit wiring system shall be complete in all respect including accessories.

Rigid conduit accessories shall be normally of grip type.

Flexible conduit accessories shall be of threaded type.

Bends, couplers etc. shall be solid type in recessed type of works, and may be solid or inspection type as required, in surface type of works.

Saddles for fixing conduits shall be heavy gauge non-metallic type with base.

The maximum number of PVC insulated cables conforming to IS : 694-1990 that can be drawn in one conduit is given size wise in Table-I and the number of cables per conduit shall be exceeded. Conduit sizes shall be selected accordingly in each run.

The erection of conduits of each sections shall be completed before the cables are drawn in.

#### **Installation-Common Aspects for both Recessed and Surface conduit Works:**

#### **Conduit Joints**

- a) All joints shall be sealed/cemented with an approved cement. Damaged conduit pipes/ fittings shall not be used in the work. Cut ends of conduit pipes shall have no sharp edges nor any burrs left to avoid damage to the insulation of conductors while pulling them through such pipes.
- b) The Engineer-in-charge, with a view to ensuring that the above provision has been carried out, may require that the separate lengths of conduit etc. after they have been prepared, shall be submitted for inspection before being fixed.

#### **Bends in Conduit**

- a) All bends in the system may be formed either by bending the pipes by an approved method of heating, or by inserting suitable accessories such as bends, elbows or similar fittings, or by fixing non-metallic inspection boxes, whichever is most suitable. Where necessary, solid type fittings shall be used.
- b) Radius of bends in conduit pipes shall not be less than 7.5 cm. No length of conduit shall have more than the equivalent of four quarter bends from outlet to out-let.
- c) Care shall be taken while bending the pipes to ensure that the conduit pipe is not injured, and that the internal diameter is not effectively reduced.

#### **Installation-Additional Requirements for Surface Conduit Work**

- a) Conduit pipes shall be fixed by heavy gauge non-metallic saddles with base, secured to suitable approved plugs with screws in an approved manner, at an interval of not more than 60 cm, but on either side of couplers or bends or similar fittings, saddles shall be fixed at a closer distance from the centre of such fittings. Slotted PVC saddles may also be used where the PVC pipe can be pushed in through the slots. The minimum width and thickness of the ordinary clips or the girder clips for different sizes of conduits shall be as given in Table-II. Where the conduit pipes are to be laid along the trusses, steel joists etc. the same shall be secured by means of saddles or girder clips as required by the Engineer-in-charge. Where it is not possible to use these for fixing, suitable clamps with bolts and nuts shall be used.
- b) If the conduit pipes are liable to mechanical damage, they shall be adequately protected.

#### **Installation-Additional Requirements for Recessed Conduit Work**

#### **Make Chase**

- a) The chase in the wall shall be neatly made and of ample dimensions to permit the conduit to be fixed in the manner desired.
- b) In the case of buildings under construction, the conduits shall be buried in the wall before plastering, and shall be finished neatly after erection of conduit.
- c) In case of exposed brick / rubble masonry work, special care shall be taken to fix the conduit and accessories in position along with the building work.

#### **Fixing Conduit in Chase**

- a) The conduit pipe shall be fixed by means of staples, or by means of non-metallic saddles, placed at not more than 60 cm apart, or shall be fixed by any other approved means of fixing.
- b) At either side of the bends, saddles/staples shall be fixed at a distance of 15 cm from the centre of the bends.

#### **Erection in RCC Work**



- a) The conduit pipes shall be laid in position and fixed to the steel reinforcement bars by steel binding wires before the concreting is done. The conduit pipes shall be fixed firmly to the steel reinforcement bars to avoid their dislocation during pouring of cement concrete and subsequent tamping of the same.
- b) Fixing of standard bends or elbows shall be avoided as far as practicable, and all curves shall be maintained by bending the conduit pipe itself with a long radius which will permit easy drawing in of conductors.
- c) Location of inspection/ junction boxes in RCC work should be identified by suitable means to avoid unnecessary chipping of the RCC slab subsequently to locate these boxes.

#### **Fixing of Inspection Boxes**

- a) Suitable inspection boxes to the minimum requirement shall be provided to permit inspection, and to facilitate replacement of wires, if necessary.
- b) These shall be mounted flush with the wall or ceiling concrete. Minimum 65 mm depth junction boxes shall be used in roof slabs and the depth of the boxes in other places shall be per IS: 2667-1988.
- c) Suitable ventilating holes shall be provided in the inspection box covers if directed.

#### **Under Floor Trunking:**

Under Floor Trunking for convenience outlet points, telephone outlets and computer outlet points shall be provided as per details given in drawings. Ducts will be manufactured from GI/MS as mentioned in BOQ with a reinforcing web as per relevant BS or relevant standards of the country of manufacture.

Triple compartment system for convenience outlets, telephone outlets and computer data outlets will be provided as specified in the BOQ. Two types of trunking shall be provided, flush floor system with removable modular covers and removable compartment partitions and Under Floor tracks as shown in the drawings or as specified in the BOQ.

Service outlet boxes and junction boxes shall be constructed from same finish as the ducting, with top frames adjustable for height at each corner. Segregation of compartments of the ducting shall be maintained through the boxes.

Each service outlet box shall have outlet units as indicated. Segregation shall be provided between power outlets and telephone outlets, with separate lids and each section shall be fitted with a cable guard or grommet. The complete assembly shall comply with requirements of Indian Telecom.

Lids of service outlet boxes and floor ducting shall be of same make unless otherwise indicated. Lids shall be arranged to accommodate the floor finish as indicated.

Under floor ducting shall be straight and level and adjusted in height to relate to the finished floor level, as indicated.

Where ducting cross expansion and settlement joints occur in the building structure, suitable provision shall be made to allow for movement of the structure. The Contractor shall submit his proposals for the approval of Engineer-in-Charge.

Open ends of ducts shall be temporarily plugged immediately after installation to prevent ingress of water and solid materials. The boxes of under floor ducting shall be fitted with temporary lids immediately after they are installed and they shall be maintained as effective protection against ingress of water and solid material until the permanent lids are fitted after screeding is complete.

Method to be used for forming fire barriers at fire resistant structural elements such as floors and walls shall be submitted for the Engineer-in-Charge's approval.

Installed ducts shall be cleaned internally with a swab before cables are drawn-in.

If the protective finish of ducting is damaged after fixing, the damage shall be made good in a manner approved by Engineer-in-charge.

#### **Routes and Segregation:**

In case the routes of conduit and ducting are not shown on the drawings, they shall be determined by the Contractor and approved by Engineer-in-Charge before work is started. This requirement shall apply where the conduit or duct is concealed within the building fabric as well as where they are on the surface.

Conduit and ducting shall be parallel with lines of building construction and properly aligned except where conduit is permitted in floor screeds. Conduit buried in wall finishes shall run vertically only, unless Engineer-in-Charge gives approval to deviate from this requirement.

A minimum clearance of 150 mm between conduits shall be allowed from any equipment/ Low current services conduit like Telephone/Computer/CCTV/ pipe work or duct work. Distance shall be measured from the external surface of any lagging. In event of difficulty in achieving this requirement, Engineer-in-Charge shall be informed.

#### **Wires:**

Flexible FRLS PVC wire shall be used for lighting wiring.

Minimum size of wire shall be 1.5 sq.mm for except for earth wiring .

The type and size of wires shall be as indicated in the BOQ. All the material supplied and used by the contractor shall be new. Wires shall have multi-strand copper conductors unless otherwise specified, and the size shall be as per IS standards unless specified.

All wires shall comply with relevant IS. Type of wire to be used shall be as specified in the BOQ.

The colour identification of wires shall comply with the IEE wiring regulations for all category of circuits. Core identification colours shall extend throughout the length of PVC insulated wires. Core identification for sound distribution or public address systems shall be in grey colour.

Wires shall be protected throughout their length by trunking, ducting, conduit and equipment enclosures. Framework or partitions may be used, but only where indicated or with the approval of Engineer-in-Charge.

Wires carrying direct current may, if desired, be bunched whatever their polarity, but wires carrying alternating current, if installed in metal conduit shall always be bunched so that the out going and return wires are drawn into the same conduit.

Where the distribution is for single phase loads only, conductors for these phases shall be drawn in one conduit.

Wires shall comply with relevant IS for LV & ELV circuits.

Where conduits cross expansion and settlement joints in the building structure, suitable provision shall be made to allow for movement of the structure. The Contractor shall submit his proposals for the approval of the Engineer-in-Charge.

Conduits entering voids shall terminate not less than 22 mm clear of the building fabric. Open ends of conduit shall be temporarily plugged immediately after they are installed to prevent ingress of water and solid materials.

Where wires pass through joints, the number and size of holes shall allow for easy withdrawal and replacement of cables. The diameter of holes shall not exceed 1/6th the depth of the joints. They shall be approximately on the centre line and shall be not less than 75 mm between centres. Joints shall not be notched.

The method to be used for forming fire barriers at fire resistant structural elements such as floors and walls shall be submitted for the Engineer-in-Charge's approval.

Where wires enter a metal enclosure, they shall be protected by grommets or secured by wires clamps.

Wires shall be looped between outlet points and as far as practicable, intermediate joints shall not be used.

Wires fixed to the surface, except in ducts, shall be protected up to a height of 1500 mm by high impact PVC channel.

Wires shall have identification sleeves at their terminations.

Identification shall be consistent with the relevant wiring diagrams.

#### **Switches:**

Switches shall be single pole unless otherwise indicated. Their current ratings shall be as indicated, allowance being made for any inductive or capacitive load.

Wall mounted switches located inside buildings shall have rocker type actuating members unless otherwise indicated. Where mounted adjacent to one another, they shall be grouped in a multi gang box with a common front plate.

Pull cord operated switches shall be fixed to white moulded plastic mounting blocks, which in turn shall be fixed to a circular conduit box. Where the conduit boxes are flush with the finish, mounting block shall overlap them. Pull cords shall be white or natural colour and the lower end shall terminate in a moulding of rubber or plastic material.

#### **Socket Outlets:**

Socket outlets shall be of type and rating as indicated. Pilot contacts shall be provided where indicated.

Socket outlets shall be switched where indicated. On socket outlets rated at 16A and located inside buildings, the switches shall be single pole and have rocker type actuating members unless otherwise indicated.

Socket outlets for wet locations shall be provided with covers, which shall be screwed on. Any cover required to achieve total enclosure and to ensure the required degree of protection against moisture shall be securely fixed to socket outlet.

Sockets/ Telephone/ TV/ CCTV/ Music / Shaver Socket outlets shall be of the type as mentioned in the BOQ.

#### **Plugs:**

ISI marked Plugs shall be provided as indicated. Plug bodies shall be of metal, plastic or other material as indicated.

Plugs rated at 16A shall be of a non-resilient material unless otherwise indicated.

Fuse plugs shall be fitted with fuses rated as indicated.

#### **Terminal Blocks:**

Conductors shall be clamped between metal surface and no screws shall make direct contact with conductors.

The design shall be such as to maintain sufficient contact pressure to ensure connections on negligible impedance at all times.

Metal in contact with conductors shall be 85% copper alloy and any screws shall be of metal that is electrolytically compatible with the copper alloy. The moulded housing shall be an insulating material suitable for the maximum operating temperature of the conductor.

**Mounting Heights:**

Mounting heights shall be as follows unless otherwise indicated in the drawings, where decision shall be obtained by contractor before start of work.

Where difficulty in locating accessories or equipment occurs the Engineer-in-Charge shall be informed.

**Supports and Fixings:**

Support shall be positioned within 300 mm of each bend and conduit box. Conduit boxes shall be fixed to fabric of building independent of the conduit. Where the conduit boxes have a minimum degree of protection of IP44, the fixing shall not reduce that protection.

Conduits shall be fixed in accordance with under mentioned Table. No shot firing shall be used and no drilling or welding of structural steel work shall be done without the approval of Engineer-in-Charge.

**Protective Conductor:**

Protective conductor shall be drawn through ducting and non-screwed metallic conduit.

Where live conductors terminate at or loop into terminals adjacent to an appliance or accessory, the protective conductor shall be terminated. Properly using earth studs, earth terminal block etc. so the case may be.

A protective conductor shall be installed within each length of steel conduit and connected to an earthing terminal at each end of the conduit.

<b>MOUNTING HEIGHTS (for accessories and equipment)</b>	
<i>Accessories or Equipment</i>	<i>Height (mm)</i>
<i>Lighting Switch</i>	<i>1200</i>
<i>Socket outlet</i>	
<b><i>Location:</i></b>	
<i>General</i>	<i>300</i>
<i>Above worktops</i>	<i>100</i>
<i>Telephone outlet</i>	<i>300</i>
<b><u>NOTES:</u></b>	
1.	Heights are from finished floor level to the center of the accessory or equipment, except in the case of worktops when the measurement shall be from the worktop surface.
2.	If the specified height of an accessory coincides with the top of tiling, the

**Outlet Boxes**

16 SWG MS/G.I. boxes of the required sizes shall be provided to house the Switch/sockets/Telephone/TV/Computer outlets as may be required/ mentioned in BOQ. These shall be so designed that there is ample space at the rear and at the sides to accommodate conductors at the conduit entries. These shall be completely concealed leaving edges flush with wall surface unless mentioned otherwise. Should the outlets have mounting grid plates, adequate supports shall be provided.

Screws and nuts shall be cadmium or zinc electroplated or passivated.

#### **Draw Boxes/ Inspection Boxes**

16 SWG Mild Steel/GI draw/inspection boxes of adequate dimensions minimum size 75 mm x 75 mm shall be provided at convenient points on walls to facilitate long runs of conductors. They will be completely concealed with 3 mm Perspex/ hylam covers flush with plate work. These boxes will, as far as possible, be located where found suitable by the Engineer-in-Charge.

#### **Protection of Conduits**

To safeguard against filling up with plaster etc. all the outlet and switch boxes will be provided with temporary covers and plugs within the tendered cost which shall be replaced by sheet / plate covers as required. All screwed and socketed joints shall be made fully water tight by the use of white lead for steel conduits.

#### **Cleaning of Conduit Runs**

The entire conduit system including outlets and boxes shall be thoroughly cleaned after completion of erection and before drawing in of cables.

#### **Laying of Dummy Conduit**

**1.26.1** The dummy conduits shall be the same as conduits for Electrical work and as specified before. The minimum size shall be 20 mm dia. Junction boxes shall be provided at distance not exceeding 10 m. The Contractor must make such modifications as the system designer / manufacturer desires in consultation with the Owners / Architects. These conduits shall be provided with steel draw boxes of at least 14 SWG.

#### **Fish Wires**

To facilitate drawing of wiring through conduits/ G.I / Steel pipes etc., G.I. fish wire of 14 SWG, wherever needed, shall be provided along with recessed conduit / pipes, without any extra cost.

**TABLE CONDUIT FIXING**

**1. Fixing of Conduit**

<u>Location</u>	<u>Type of fixing</u>
Floor screeds	Saddles
Buried in plaster or render	Crampets or saddles
Above false ceilings	Spacer bar saddles
Surface	Distance Saddles

**2. Fixing of Saddles, Conduit Boxes**

<u>Building Fabric</u>	<u>Type of fixing</u>
Structural steelwork (type to be approved by Engineer-in-Charge)	Purpose made clamps
Non-Structural steelwork	Sets screws and nuts.
Concrete, brick or Blocks	Fiber plugs & screws

**Table –I**

**Maximum number of PVC insulated 650/1100 V Grade Aluminium/Copper conductor cable conforming to IS:694/1990**

Nominal Cross sectional area of cond. in sq. mm	20mm		25mm		32mm		38mm		51mm		64mm	
	S	B	S	B	S	B	S	B	S	B	S	B
<b>2.5</b>	5	3	8	6	12	10	-	-	-	-	-	-
<b>4</b>	3	2	6	5	10	8	-	-	-	-	-	-
<b>6</b>	2	-	5	4	8	7	-	-	-	-	-	-
<b>10</b>	2	-	4	3	6	5	8	6	-	-	-	-
<b>16</b>	-	-	2	2	3	3	6	5	10	7	12	8
<b>25</b>	-	-	-	-	3	2	5	3	8	6	9	7
<b>35</b>	-	-	-	-	-	-	3	2	6	5	8	6
<b>50</b>	-	-	-	-	-	-	-	-	5	3	6	5
<b>70</b>	-	-	-	-	-	-	-	-	4	3	5	4

**NOTE:-**

- The above table shows the maximum capacity of conduits for a simultaneous drawing in of cable.
- The columns headed 'S' apply to runs of conduits which have distance not exceeding 4.25 m between draw in boxes and which do not deflect from the straight by an angle of more than 15 degrees. The columns headed 'B' apply to runs of conduit which deflect from The straight by an able of more than 15 degrees.
- Conduit sizes are the nominal external diameters.

<b>TABLE-II</b>			
<b>Girder Clips or Clamps</b>			
<b>S.NO.</b>	<b>Size of conduit</b>	<b>Width</b>	<b>Thickness</b>
1	20 mm	19mm	0.9mm (20 SWG)
2	25 mm	19mm	0.9mm (20 SWG)
3	32 mm & above	25mm	1.2mm (18 SWG)

**TABLE-III**

<b>Dimensional details of rigid non-metallic conduits.</b> (All dimensions in mm)					
-----					
S.No.	Nominal Outside Permissible diameter (in mm.)	Maximum Outside- diameter (in mm.)	Minimum Inside- diameter (in mm.)	Maximum Permissible eccentricity (in mm.)	Maximum ovality (in mm.)
-----					
1.	20	20+0.3	17.2	0.2	0.5
2.	25	25+0.3	21.6	0.2	0.5
3.	32	32+0.3	28.2	0.2	0.5
4.	40	40+0.3	35.8	0.2	0.5
5.	50	50+0.3	45.0	0.4	0.6

## **MCB DISTRIBUTION BOARDS:**

### **Scope:**

The scope of this section covers Supply, installation, testing and commissioning of Miniature circuit breaker boards and Miniature Circuit breakers. Miniature circuit breaker boards shall comply with BS 5486 part 12 a clause 2.2 and 2.3. They shall have a fault withstand classification of class 1 unless otherwise indicated.

### **MCB Distribution Boards**

These distribution boards shall be used for control of all lighting/power circuits and shall consist of single / double / Triple Pole / triple pole and neutral / four pole miniature circuit breakers mounted in double cover design, dust tight, heavy gauge sheet steel enclosures preferably zinc coated with powder coating finish.

Distribution Boards shall be flush or surface pattern according to the requirements of their location and shall incorporate isolators / MCB and circuit switches as specified in bill of quantities.

All MCBs shall be connected to the electrolytic copper busbars with direct bolted connections.

Earthing bar and neutral bars shall be provided having sufficient ways to enable each cable to be connected to a separate terminal. Neutral connections shall be corresponding in position to phase connections.

Distribution boards shall have phase barriers and PVC ducts for all interior wiring. All distribution boards shall have removable end plates at top and bottom and handles with provision for locking.

Phase barriers shall be provided in the 3-phase distribution Boards.

In TP&N distribution boards, neutral busbars shall have one outgoing terminal for each outgoing circuit.

Size of SDB shall be selected to cater to extra space on the bus for mounting ELCBs in addition to number of outgoing MCBs specified in the BOQ.

A multi-terminal bar for the circuit protective conductors shall be provided for both insulated and metal cased boards, with one terminal for each outgoing circuit. It shall be directly connected to the earthing terminal without dependence on the exposed conductive parts of the enclosure.

Identification of each MCB way shall be by numbering. Identification in the neutral busbar and protective conductor bar shall clearly relate each terminal to its respective MCB way.

Spare MCB ways shall be provided as indicated in BOQ. Where specific ratings are indicated, MCB shall be incorporated otherwise the ways shall be left blank but suitable for future additions. Suitable number of blanking plates shall be fixed in the DB if the space for MCB is left blank.

A separate Junction box of min. height of 150 mm shall be provided for extra lengths of outgoing circuit wires on Top/Bottom (as required) to avoid jumbling of wires within the main section of SDB. The junction box will be properly earthed alongwith the SDB.

MCB DBs shall be factory fabricated of reputed manufacture and the make shall be as specified in BOQ/ List of approval.

### **Miniature Circuit Breakers**



Miniature circuit breakers shall be designed and tested strictly in accordance with the relevant parts of Indian standards and shall consist of spring accelerated quick-make and quick break action mechanism fitted in moulded cases of high di-electric strength plastic or urea. Fixed and moving contacts shall have silver tungsten contacts.

Miniature circuit breakers used shall be of "B" Series for Normal lighting circuits and Normal Power/Geyser Loads. For AC loads, Tungsten lamps fittings, Sodium/Mercury Discharge lamps "C" Series shall be used unless otherwise specified.

Miniature circuit breakers shall have a minimum breaking capacity of 10 KA at 415 V unless otherwise specified.

Make of MCB shall be as specified in the BOQ / List of approved makes.

#### **ELCBs**

ELCBs shall be designed and tested strictly in accordance with the relevant parts of Indian standards. Fixed and moving contacts shall have silver tungsten contacts.

ELCBs used shall be of Rating and sensitivity as specified in the BOQ.

ELCBs shall have a breaking capacity of 10 KA at 415 V and shall be ordinarily be for Earth Leakage protection unless otherwise specified.

Make of ELCB shall be as specified in BOQ/ List of approved makes.

### **LUMINAIRES AND LAMPS:**

#### **Scope:**

The scope of this section comprises of Supply, erection, testing and commissioning of lighting fixtures for internal lighting, wherever required, of the specified models.

Without restricting to the generality of the foregoing, this section shall include luminaries, lamps and accessories necessary and required for the installation.

Whether specifically mentioned or not, the luminaries and lamps shall be provided with all fixing devices, terminal blocks, holders etc. as required.

#### **General Requirements:**

All the luminaries and lamps shall be of best quality and as per approved makes. Wherever alternative makes are specified the choice of selection shall remain with the Engineer-in-Charge.

The luminaries and lamps shall be fixed in a neat work man like manner, true to level and in accordance with manufacturer's instructions.

The luminaries and lamps shall be provided with such accessories as are required to complete the item in working condition whether specifically mentioned in the specifications, drawings or not.

#### **Luminaries:**

Luminaries shall comply with relevant IS.

Unless otherwise indicated, enclosure of luminaries shall provide a minimum degree of protection of IP20 when located within buildings and IP44 when located outside buildings, but luminaries mounted externally; and less than 2 M above finished ground or paved level shall be IP54 unless specified in BOQ.

Unless otherwise indicated, luminaries, both with and without built-in ballast or transformers shall be suitable for direct mounting on normally flammable surface.

Where specific requirements related to flame propagation and flammability of translucent covers are indicated, certificates of tests shall be submitted to the Engineer-in-Charge. The tests shall comply with relevant IS.

Terminal blocks for connection of the supply cables shall be of adequate size for the size of conductors forming the loop in wiring unless separate tails are required. Wherever indicated, the terminal block shall incorporate a fuse of suitable type and rating.

Ballasts for tubular fluorescent lamps shall have a maximum value of harmonics complying with the colour headed "without H Marking" in Table VII of BS 288. Power factor correction shall be provided and this shall not be less than 0.85 lagging unless otherwise indicated.

Translucent covers and reflective surfaces shall be clean at the completion of the works.

#### **Lamps:**

Lamps shall be of the type and ratings as indicated.

All lamps shall be supplied and installed by the contractor unless otherwise directed.

Lamp caps shall be suitable for the lamp holders listed socket by means of a locking ring.

#### **Support and Fixings:**

Where fluorescent luminaries 1200 mm or more in length are supported directly by the conduit system, they shall be fixed to two circular conduit boxes both of which shall form an integral part of the conduit system.

Where the weight of a luminaries is supported by a conduit box or cable trunking, the fixing of the conduit box or trunking shall be adequate for the purpose and approved by Engineer-in-Charge.

Luminaries fitted with tungsten filament lamps and having metal back plates shall not be fixed directly to conduit box in which thermoplastic material is the principal load bearing member.

Support of luminaries from cable trunking shall be by means of proprietary clamps or brackets.

Where luminaries are supported from the structure other than by the conduit system, the supports shall be adequate for the purpose and approved by Engineer-in-Charge.

Luminaries mounted on or recessed into suspended ceilings shall not support luminaires unless specifically shown and approved.

For wall mounted luminaries, the mounting height shall be 1900 mm above finished floor level, measured to the center of the conduit box, unless otherwise indicated.

#### **Wiring Connections:**

Where luminaries, are fixed at places other than circular conduit boxes or are supported by pedants or chains, the final circuit wiring shall terminate at a terminal block in the conduit box.

Where luminaries having fluorescent tubes are fixed direct to circular conduit boxes, the final circuit wiring may be terminated within the luminaries unless otherwise indicated. The wiring shall enter each luminaire at the conduit entry nearest to the terminal block and where a loop in wiring system is used, leave by the same entry; wiring shall not pass through a luminaries unless the approval of the Engineer-in-Charge.

Where luminaries are mounted on or recessed into a suspended ceiling, connection shall be by flexible cord from a plug-in ceiling rose unless otherwise indicated. The plug-in ceiling rose shall be located not more than 500 mm from the access in the ceiling and shall be firmly supported, unless otherwise approved by the Engineer-in-Charge.

Cables and flexible cords for final connections to luminaries shall be suitable for the operating temperature of the luminaries.

The size of final connection cables or flexible cords shall be as indicated.

Cables and cords passing close to a ballast within a luminaries shall be suitable for the operating temperature of the ballast.

A protective conductor shall connect the earthing terminal or earthing contact of each luminaire to an earthing terminal incorporated in the adjacent conduit box. Where the final connection is by flexible cord, the protective conductor shall form part of the cord.

## **External Lighting**

### **Scope:**

The specifications covers the supply, installation, testing and commissioning of the following items as specified in the BOQ:-

- a) Street/Boundary lighting poles complete with all accessories e.g. looping box, clamps and required hardware etc.
- b) Street/boundary lighting fixtures complete with all accessories e.g. lamps latest etc.
- c) Wiring of street light fixtures.
- d) Cable laying, earthing and inter connection
- e) Foundation of poles and erection.

All the items should be tested and installed as per the latest Indian standards specifications and all the sundry items such as clamps, bolts, nuts, racks, support, miscellaneous wiring etc., required to make the installation complete shall be taken care while quoting the major items.

### **GALVANISED OCTAGONAL POLE:**

The poles for external lighting purpose shall be complete in all respects and shall conform to IS: 2713 unless otherwise specified. Poles shall be complete with base plate of 220 mm x 220 mm x 12 mm, 310 mm x 310 mm x 16 mm & 310 mm x 310 mm x 20 mm thick welded to bottom. The poles shall be provided terminal box for looping in and looping out of cables and shall consist MCB as specified. The looping box shall be suitable for outdoor installation and complete with all hardwares such as clamp, bolts, earthing studs, lockable door etc. and shall be paint also in the same manner as specified for poles. The poles shall be provided with two numbers of GI pipes of 40 mm dia for cable entry as shown in drawing. Two coats of aluminium paint of approved shade after erection over the exposed portion.

### **ERECTION OF GALVANISED OCTAGONAL POLE:**

While loading, transporting, unloading and erecting the poles care shall be taken so that the poles do not get bent. Out of shape and where necessary such defects shall be rectified before the poles are erected in position. The poles shall be erected in plumb line and correct level as indicated in the drawing and to the satisfaction of the Engineer-in-charge. They shall be kept in this position with the help of manila ropes until the foundation is constructed (for a minimum period of 10 days) and the backfilling is complete. Foundation shall be made with reinforced cement concrete (1:3:6) and not less than 200 mm thick all round. The pole base plate shall be fixed over 150 mm thick concrete bed. Foundation shall be continued upto 150 mm or more above ground level as per location of the pole to avoid ingress of water logging etc. The foundation shall be tapered suitably into a collar. The excavated portion shall be filled back with earth and consolidated. The cement concrete foundations shall be cured properly by covering the same with water soaked or moist gunny bags at least two weeks before loading the pole.

#### **Erection of Light Fixtures:**

Each light fixture shall be connected to the supply through MCB of a suitable rating mounted in the looping box. The fitting shall be fixed to the pole properly and securely. Looping box shall be as specified in the BOQ.

#### **Wiring of Light Fixtures:**

The wiring of lighting fixtures from terminal block by means of minimum 2.5 sq.mm FRLS/PVC insulated single multicore copper conductor through a suitable rated MCB and neutral as specified. Cost of single core connecting cable from junction box to lighting fixture and earth wire complete with connections are included in the quoted rate as specified.

#### **Feeder Pillar:**

Feeder Pillar shall be of floor mounting cubical type, free standing type, suitable for outdoor installation, dust, vermin and weather proof construction. The Feeder Pillar shall be of Minimum IP 54 construction.

This shall be suitable for Continuous operation on 415 V (normal) 3 Phase 4 wire 50 Hz supply. The number, type and capacities of protection gear forming part of the Feeder Pillar assembly shall be specified in the tender documents.

The installation shall be done at locations approved by the Engineer-in Charge.

Hinged doors of the same material shall be provided on the front and rear side with necessary handle and inbuilt locks with double keys. Neoprene gaskets shall be provided for the doors.

Detachable Gland plates shall be provided at the bottom, with double brass compression type glands of the sizes to be specified.

Bus bars and Bus bar supports shall conform to relevant clauses of the respective heads.

The Feeder pillar cubical type shall be installed on a suitable pedestal of masonry or RCC as may be specified. The minimum height of the Feeder pillar from the ground shall be 45 cm. This may be increased considering the local conditions or as specified.

MV danger plate shall be provided on each door.

Circuit details should be indicated on the back of one of the doors.

The feeder pillar shall be earthed with 2 Nos. of GI Pipe electrodes or as specified.

#### **Cabling Works:**

All cable installation work shall be done as per relevant clauses of section Cable works.

#### **Tests:**

Before handing over the installation, tests on all fittings and cables shall be carried out as per IS specification.

The tests shall include:-

- a) Meggar Test
- b) Continuity Test

Polarity test and phase sequence test.

## **LT POWER DISTRIBUTION CABLES:**

### **Scope:**

The scope of this section covers the supply, laying, testing and commissioning of overhead and underground LT cables as specified in Bill of Quantities.

### **LV cables:**

Cables shall be PVC/XLPE insulated and shall be of 650/1100 volts grade or as specified and shall have been manufactured confirming to BS 6346 and Indian Standard Specifications IS-694 and IS-1554 as applicable. These shall be of approved types accepted by the Fire Insurance Association of India for use in Industrial risks and to the following specifications. The contractor shall submit the Manufacturer's catalogues giving electrical characteristics of the cables.

The fire retardant low smoke (FRLS) cables shall be 650/1100V grade multicore having annealed tinned copper wires, insulated with special polymeric material suitable to withstand 150 degree for 30 minutes, cores laid up melinex taped, special low halogen and low smoke elastometric material inner sheathed black, armoured with G.I. Wires/cast steel strips, melinex taped outer sheathed with special low halogen and low smoke elastomeric material unless otherwise specified.

### **Multi-core Cables:**

These shall be as specified and small comprise of plain, circular, solid/ stranded Al conductors. PVC insulated and having an inner sheath of PVC compound, galvanized flat steel tape or round steel wire, armouring and PVC sheath overall and shall comply with IS:1554-1961.

### **Flexible Cables:**

Twin flexible cables used for pendants and connections to other lighting fixtures shall have cross-section area or should be of 0.001sq. Inch (equivalent to 23/0.0076) or larger and be insulated in accordance with relevant IS specifications. The metric equivalent size for 23/0.0076 wherever mentioned may be noted as 23/0.20mm. All wires and cable shall be of FRLS type.

### **Jointing and Terminating Cables:**

Joints and terminations shall comply with the following clauses as appropriate to the type of cable. The Engineer-in-Charge shall be informed where it is proposed to install joints that are not indicated.

The Engineer-in-Charge shall be given evidence that the joint or termination manufacturer has stated the materials to be employed are suitable for the type of cable to be jointed or terminated.

Cable shall not be cut until the jointing or terminating commences and the work shall precede continuity until it is completed. All necessary precautions shall be taken to prevent damage and ingress of moisture and impurities; cable ends shall be free from moisture before jointing commences. Where circumstances prevent, completion the cable ends shall be sealed. In the case of lead sheathed cables this shall be by plumbing and for aluminium sheathed cables by hermetically sealing.

The Contractor shall employ for this work, staff who is fully qualified and competent or the types of joints and terminations to be made.

Core identification shall be matched at each joint without twisting or crossing of the cores. Where numbered cores are jointed to coloured all cable runs and on sites with existing installations consistent with the system already in use.

For joints in armoured cables, a bonding conductor shall be connected across the armouring. A split ferrule shall be placed under the armouring to prevent deformation of the cable by the clamp.

At terminations, armouring and metal sheaths shall be connected directly to the external earthing terminal of the equipment by a bonding conductor. For LV cables the bonding conductor shall have a cross sectional area in accordance with Table 54P of IEE wiring Regulations. Metal sheaths of single core cables shall be bonded and earthed at one point only, as indicated, insulated glands shall be used at the open- circuit end or ends.

At terminations, cable tails shall be formed by separating and bringing out the cores. Each tail shall be long enough to connect to the terminals of the equipment.

At the terminations of single core cables, gland plates shall comply with relevant clause. For three phase circuits the phase conductors shall be arranged, if possible, in trefoil formation where they pass through the enclosure of equipment.

Core identification at terminations shall be by coloured or numbered plastic stretch or shrink ferrules.

Continuity of spare cores shall be maintained at joints and at terminations, the cores shall be connected to spare terminals.

Solder shall be used only for connecting or terminating paper-insulated cables. All other connections and terminations shall be by means of compression fittings or mechanical clamps.

Compression connectors and associated dies for compression tools shall be of correct type and size. Tools shall be so designed that the correct compression must be applied before it can be released.

#### **Cable Identification:**

For multi core cables, PVC ferrule type indicators or tags shall be provided at both ends for core identification. For phase identification of 2/3/3.5/4 core cables, coloured PVC tapes shall be used at both ends.

All cables shall be provided with aluminium tags of approved design, spaced not less than 7.5 meters. Apart and these shall contain the following:

- a) Feeder No.
- b) Size
- c) No. of Cores

#### **Sleeves, Tapes and Sealing Compounds:**

Sleeves shall be of the shrink type applied cold by mechanical device or by the use of heat, they shall provide a sufficient thickness of insulation to suit the particular application.

Insulating tapes used in joints and terminations shall be compatible with and have a temperature rating and insulating property not less than the cable insulation. They shall be complying with BS 3925.

Impregnated cotton tapes shall be double selvaged.

All tapes shall be stored in sealed containers until required.

Resin filling should be, as far as is reasonably practicable, safe and without risk to health. Each pack shall include warnings as to any hazards in its use, e.g. dermatic or toxic properties with details of precautions, which the user must take to minimize these.

Hot pouring sealing compound shall be hard setting and comply with BS 1858:1973 (1986). Selection of the compound shall take account of the ambient temperature of installation as well as characteristics of the joint.

Care shall be taken to prevent voids occurring in consequence of too rapid cooling.

Resin filling shall be used with PVC/ XLPE type cables and hot poured compound shall be used with paper insulated lead covered cables.

### **Cable Supports:**

Unless otherwise indicated the type of cable supports used shall be selected by the Contractor to suit the circumstances of the installation, but they shall comply with these specification and the following preferences shall be taken into account:

For Horizontal runs	Cable Tray
For vertical runs	Clabber Cleats
Where marshalling of cables occurs e.g. at switchboards	Cable Racks.

Unless otherwise indicated all ferrous metal for cable tray, cable racks, and cable ladder, cable hangers and their fixings and suspensions shall have a galvanized finish.

For general use inside buildings the galvanized finish shall be a coating equivalent to and not less than type G275 to BS 2989, but manufacturer's standard finishes will be accepted for slotted angles. All metal exposed during fabrication shall be given a coat of zinc-rich paint, brushed on or finished to match the manufacturer's finish.

Metal cable tray shall be used unless otherwise indicated and it shall comply with these specifications where cables are laid in the cable tray they shall be secured by ties, each tie securing the cables of only one circuit. The ties shall be of a proprietary type not requiring screws or bolts for fixing the use of wire or similar material will not be permitted. Ties shall be spaced at not greater than 600 mm along each cable and within 100 mm of each bend or set.

Where cable tray is installed in the veritable plane, cables shall be supported by cable cleats.

Cable tray shall be fixed at regular internals not exceeding 1200 mm and at 225 mm from bends and intersections. A minimum clear space of 20 mm shall be left behind all cable trays.

### **Cable Cleats:**

Cable cleats shall be made from materials, which are resistant to corrosion without the need for treatment of special finish.

Cable cleats shall be of a size such that they can be tightened down to grip the cables without exerting undue pressure or strain on them. For vertical cable two bolt cable cleats shall be used which shall grip the cables firmly enough to prevent them slipping.

The spacing of cable cleats shall comply with the IEE Wiring Regulations. At bends in the cable, cleats shall be located immediately on each side.

### **Cable Racks:**

Cable racks shall comply with these specifications and shall be constructed from proprietary systems using channel sections with return lips and compatible fixing accessories, factory formed cable ladder may also be used

Cable shall be fixed to the racks and ladders by cable cleats.

### **Cable Hangers:**



Cable hangers shall be used only where indicated. They shall be made from mild steel flat bar complying with these specifications.

**Suspensions and Fixings:**

It is preferred that proprietary suspension systems comprising channel sections with return lips and compatible fixing accessories or slotted angles should be used, Where necessary fixing may be fabricated from mild steel flat bar. Metal arc welding shall comply with BS 5135.

Unless otherwise indicated fixing to the building fabric shall comply with table below:

<b><u>TABLE-FIXING FOR CABLE SUPPORTS</u></b>	
<i>Building fabrics</i>	<i>Type Fixing</i>
Structural Steel work	Purpose made clamps (Type to be approved by Engineer-in-Charge)
Non-structural steel work	Bolts, Washers and nuts.
Expanding anchors	Concrete brick or building Blocks
Timber	Coach bolts
<hr/>	
<u>Note:</u>	Where cable cleats are fixed direct to concrete, brick or building block, fiber plugs and screws may be used as appropriate.

No shot firing shall be used and no drilling or welding of structural steel shall be done without approval of the Engineer-in-Charge.

Suspensions and fixings shall be comply with relevant clause.

Bolts, nuts, washers and screws shall be cadmium or zinc Electroplated or passivated.

**Bonding:**

Supplementary bonding shall be installed between component parts of cable trays, racks or ladders where the method of mechanical connection does not provide permanent and reliable metal to metal joints of negligible impedance.

**Cable Installation:**

Unless the routes of cables are indicated on drawings, they shall be determined by the contractor and approved by the Engineer-in-Charge before work is started.

Cable installation on the surface shall be parallel with the lines of building construction and properly aligned.

A minimum clearance of 150mm shall be allowed from any equipment, pipe work or duct work. The distance shall be measured from external surface of any lagging.

In the event of difficulty in achieving these requirements, Engineer-in-Charge shall be informed.

Spacing between cables shall comply with relevant table, but where indicated account must be taken of any grouping necessary to maintain the current carrying capacities of cables.

Space shall be allowed along cables routes for future additions where indicated and cable supports shall be of adequate size for the ultimate load.

Adequate space shall be left between cable runs, the building fabrics and other services to allow for future removal or installation of cables.

Cables shall be adequately supported by one of the methods specified in clause 9.8 throughout cable ducts or are buried direct in the ground. Fixing direct to building fabric by cable cleats may be adopted for single runs subject to the approval of Engineer-in-Charge, and where indicated.

Cables shall be supported within 30mm of their termination at equipment; the weight of the cable shall not be carried by the terminal box gland.

Where cables cross expansion and settlement joints in the building structure, they shall be fixed 300 mm each side of the joint and sufficient slack left between to allow for movement. Where the cables are buried in the building fabric suitable provision shall be made to allow for movement of the structure. The contractor shall submit his proposals for approval of Engineer-in-Charge.

#### **Handling of Cables:**

Cables shall be handled with care and every effort made to avoid damage to the cables, to other services and to building fabric. Recommendations or instructions available from the cable manufacturers concerning the installation of cables shall be taken into account. In particular co-axial cable shall not be bent in radius less than six times the overall diameter. Any damage shall be reported immediately to Engineer-in-Charge.

#### **Marking of Cables:**

Cables located in switch rooms, ducts and spaces designated solely for electrical services or have orange over sheaths, they shall be identified by adhesive bands coloured orange, complying with BS 1711. The bands shall not be less than 100 mm long, located at least once within each separate compartment through which the cables pass at intervals not exceeding 12 m.

Except where cables are buried or enclosed in conduit, trunking or ducting, they shall be permanently identified by discs. Discs shall be of laminated plastic materials with black characters on white: characters shall be not less than 3 mm high. The inscription shall indicate nominal voltage, designation of load, number and cross sectional area of cores and rated voltage of cable.

Cable identification discs shall be attached to the cables with ties. Discs shall be located within 500 mm of terminations and joints, at least once within each separate compartment through which cables pass and at intervals not exceeding 24 m, they shall coincide with the colour bands.

#### **Laying Cables in Ground:**

Cables shall be laid by skilled experienced workmen using adequate rollers to minimize stretching of the cables. The cable drums shall be placed on jacks before unwinding the cable. With great care it shall be unrolled on over wooden rollers placed in trenches at intervals not exceeding 2 meters. Cables shall be laid at depth of 0.75 meters below ground level. A cushion of sand total of 250mm shall be provided both above and below the cable, joint boxes and other accessories. Cable shall not be laid in the same trench or along side a water main.

The cable shall be laid in excavated trench over 80mm layer of sand cushion. The relative position of the cables, laid in the same trench shall be preserved. At all changes in direction in horizontal and vertical planes, the cables shall be bent smooth with a radius of bent not less than 12 times the diameter of cables. Minimum 3 meter long loop shall be provided at both end of cable.

#### **Laying in Pipes / Closed Ducts :**

The size of the pipe shall be decided by the Engineer-in-Charge and shall not be less than 10 cm, in diameter for a single cable and not less than 15 cm for more than one cable. These pipes shall be laid directly in ground without any special bed except for SW pipe which shall be laid over 10 cm, thick cement concrete 1:5:10 (1 cement : 5 coarse sand: 10 graded stone aggregate of 40 mm nominal size) bed. No sand cushioning or tiles need be used in such situations. Unless otherwise specified, the top surface of pipes shall be at a minimum depth of 1m from the ground level when laid under roads, pavements etc.

Where steel pipes are employed for protection of single core cables feeding A.C. load, the pipe should be large enough to contain both cables in the case of single phase system and all cables in the case of polyphase system.

The pipes on road crossings shall preferably be on the skew to reduce the angle of bend as the cable enters and leaves the crossing. This is particularly important for high voltage cables.

Manholes of adequate size as decided by the Engineer-in-Charge shall be provided to facilitate feeding/drawing in of cables and to provide working space for persons. They shall be covered by suitable manhole covers with frame of proper design.

Pipes shall be continuous and clear of debris or concrete before cable is drawn. Sharp edges at ends shall be smoothed to prevent injury to cable insulation or sheathing.

Pipe for cable entries to the building shall slope downwards from the building and suitably sealed to prevent entry of water inside the building. Further the mouth of the pipes at the building end shall be suitably sealed to avoid entry of water.

All chases and passages necessary for the laying of service cable connections to buildings shall be cut as required and made good to the original finish and to the satisfaction of the Engineer-in-Charge.

Cable grips / draw wires and winches etc. may be employed for drawing cables through pipes/closed ducts etc.

#### **Laying in Open Ducts:**

Open ducts with suitable removable covers shall be preferred in sub-stations, switch rooms, plant rooms, workshops etc.

The cable ducts should be of suitable dimensions so that the cables can be conveniently laid. If necessary, cables may be fixed with clamps on the walls of the duct or taken in troughs in duct. The duct should be covered with removable slabs or chequered plates.

Ducts may be filled with dry sand after the cable is laid and covered as above or finished with cement plaster specially in high voltage applications.

Splices or joints of any type shall not be permitted inside the ducts.

As far as possible laying of cables with different voltage ratings in the same duct shall be avoided.

Where considered necessary, hooks or racks shall be provided for supporting the cables in masonry / concrete cable ducts, cable troughs. Otherwise cables shall be laid direct in the trench or trough etc. While deciding the layout of cables in such ducts, care should be exercised to ensure that unnecessary crossing of cables is avoided.

#### **Protection of Cables:**

The cables shall be protected by bricks laid on the top layer of the sand for the full length of underground cable. Where more than one cable is laid in the same trench, the bricks shall cover all the cables and shall project a minimum of approximately 80mm on either side of the cables. Cable under road crossings and any other places subject to heavy traffic shall be protected by running them through Hume Pipes of suitable size.

## **EARTHING**

### **Scope:**

The scope of this section covers supply installation and testing of earthing system for all non-current carrying metal parts of electrical installation.

The type and number of earth electrodes shall be as indicated and shall comply with clauses as appropriate.

Dedicated earthing shall be provided for the Server Room equipments.

### **Earthing System & Equipment Bonding:**

Unless otherwise indicated, earth plates shall be 600 mm x 600 mm minimum, of solid or lattice copper not less than 3.15 mm thick and of GI not less than 6.3 mm.

Earthing system shall comprise of earth electrode near sub-station. Test link boxes shall be provided at each electrode for periodical resistance measurement. All such earth electrodes shall be interconnected forming a main grid.

Where the earth electrodes are formed with tape, the tape shall be to relevant IS, of the size, length, depth below ground level and layout as indicated.

### **Conductors:**

Earthing conductors, main earthing bars and main equi-potential bonding conductors shall be of the type, size and conductor material as indicated and shall comply with the following clauses.

Tapes shall comply with relevant IS. Where used to interconnect copper electrodes the tape may be bare, but for interconnecting pipe electrodes and for all other purposes the tap shall have an extruded PVC sheath.

Main earthing bars shall comply with IS 3043 and shall be bare.

Cables shall comply with IS 3043, without sheath, unless otherwise indicated.

### **Joints and Connections:**

Joints in conductors shall be kept to a minimum.

All contact surfaces shall be thoroughly cleaned and coated with an anti-corrosive electrical jointing compound suitable for the conductor materials. For bi-metalllic joints, a separate abrasive shall be used to clean each metal.

### **Connections shall be made as follows:**

to main earthing bars by phosphor bronze set screws and nuts;

to earth rods by bronze, gunmetal or copper clamps with phosphor bronze. Edges of clamps shall be rounded;

to earth pipes by phosphor bronze bolts and nuts, direct to the flange of the pipe;

to earth plates by bolting, rivetting or welding.

Termination of cables shall be by connectors jointed to the cable conductor by the thermit welding process or by compression joints complying with BS 4579.

Joints which are indicated as test points shall be bolted or clamped. Joints in tape, other than at test points shall be made by the reventing and sweating. Overlap of conductors shall be not less than 100 mm.

Joints and connections shall be protected by a coating which will form a seal and exclude moisture in all weather conditions. At connections to earth electrodes, the coating shall cover all exposed conductors and in the case of earth pipes, to top surface of the flanges. Protective coatings shall be of a waterproof, inert, tenacious material and of one of the following forms:

- a) solvent cutback thixotropic corrosion preventative forming a film of resilient matt petroleum wax;
- b) a fast drying durable rubberised sprayed coating;
- c) a heat shrink clear sheathing

Screws, nuts, washers and rivets for copper conductors shall be of phosphor bronze, naval brass or copper silicon; for aluminium conductors, they shall be of stainless steel. The minimum provision shall be

- a) for flat strip--- two M8 bolts or four 5 mm diameter rivets;
- b) for sheet metal--two M8 bolts; where the sheet metal is less than 2 mm thick, it shall be backed for an area of at least 1000 mm<sup>2</sup>.

#### Inspection Pits:

Unless otherwise indicated, connection between an earth conductor and its associated earth electrode system shall be in an enclosure.

The enclosure shall have a removable top cover which shall be flush with finished ground level. The enclosure shall be a purpose made concrete inspection pit, a galvanised steel inspection pit embedded in concrete, an earthenware pipe or similar, as indicated. The earth electrode connection shall be just below the lid of the inspection pit with adequate access for testing purposes.

#### **Supports and Fixings:**

Cables shall be supported and fixed in accordance with Section Cable laying.

Tapes and bars shall be fixed by spacer bar saddles which shall be of non-metallic material or corrosion resistant alloy compatible with the conductors. Fixing of saddles shall comply with relevant clauses in Cable Laying section. The maximum spacing off fixings shall not exceed 600 mm unless otherwise indicated.

Main earthing bars shall be supported on insulators; they shall be not less than 25 mm clear of the building fabric.

For general areas inside buildings, screws and nuts shall be of cadmium electroplated steel or stainless steel; outside buildings, in plant rooms or other locations as indicated, they shall be of stainless steel.

No shot firing shall be used and no drilling or welding structural steelwork shall be done without the approval of the Engineer-in-Charge.

#### **Installation:**

Electrodes shall be installed in undisturbed ground. The distance between any two electrodes shall be not less than 1.25 times the depth of the longer electrode.

Excavations shall be carried out in accordance with BS 6031 and shall comply with the construction (General Provisions) Regulations, 1961. Excavations shall be kept free of water and protected against damage or collapse. The safety of persons and the protection of structures, buildings, roads, sewers and services from damage shall be ensured; all necessary sheeting, timbering, strutting and shoring shall be supplied, erected and subsequently removed.

Trenches shall be backfilled in layers and each layer shall be rammed. The first two layers shall be 100 mm deep and rammed by hand the remaining layers shall be not more than 200 mm deep and power ramming may be used. Warning tapes and covers shall be included as specified in relevant clauses in Cable laying section. Where applicable, top soil and turf shall be replaced and the final level shall be level with or not more than 25 mm above the adjacent ground level.

The earth resistance should be less than 2.0 Ohms. Earth Pits shall be treated with salt, charcoal /chemicals to be achieve the required result.

## **INSPECTION AND TESTING:**

### **General:**

Inspection and testing shall be done in accordance with the IEE Wiring Regulations, the requirements of this Section and as indicated.

Inspection shall include a physical check that all equipment has been securely fixed and that all electrical connections are mechanically sound.

In addition to the test at the completion of each installation, certain tests shall be done during the progress of the Works as required by relevant clauses of these specifications.

### **Information:**

For equipment supplied under the contract, the Contractor shall obtain from manufacturers the time/current characteristics of all protective devices for automatic disconnection of supply and provide copies to the Engineer-in-Charge and to the person or persons carrying out the inspection and testing, in addition to meeting the requirements of clause.

### **Testing Methods:**

The Engineer-in-Charge shall be notified of the method to be used for each type of test and the notification shall be given not less than 28 days before the final tests are to be made. The tests shall be carried out in accordance with the methods set out in the IEE Wiring Regulations, subject to the requirements of following clauses.

For testing, continuity of protective conductors and equip-potential bonding AC source shall be used unless the Engineer-in-Charge agrees otherwise.

The method used to verify the effectiveness of the protection afforded by a residual current-operated device shall give the operating time and the current used shall not exceed 100% of the nominal setting of the device. For a fault voltage operated device, the test voltage between the exposed conductive part and earth shall not exceed 50 volts. In addition to the tests simulating an appropriate fault condition, any test facility incorporated in the device shall be operated to test its effectiveness.

High Voltage tests on LV cables and factor assemblies shall comply with the requirements for site testing in the appropriate British Standards.

Alternative methods to those set out in the IEE Wiring Regulations may be proposed for the approval of the Engineer-in-Charge, but they shall be not less effective than those in the Regulations.

Where necessary to prevent damage to components of equipment, the equipment shall be disconnected for the duration of the relevant tests.

### **Power Cables:**

Tests shall be made immediately on completion of the installation of power cables to demonstrate that the phase sequence is correct at all end connections.

Where indicated, LV cables shall be tested at high voltage in accordance with these specifications.

LV cables not required to be high voltage tested, shall be tested for insulation resistance as soon as their installation is complete. The test voltage shall be 500V DC for installations rated up to 500V and 1000V Dc for installations rated up to 1000V. Tests shall cover all permutations between each conductor, screen, metallic sheath, armour and earth.

The over sheaths of cables laid under ground shall be given a voltage withstand test after backfilling of the trenches is complete but before termination.

#### **Control and Communication Cables:**

Cables shall be tested as soon as their installation is complete to ensure that the cores are continuous and they have not been crossed and the insulation resistance is satisfactory. Insulation tests shall cover all permutations between each conductor, screen, metallic sheath, armour and earth.

For polyethylene and dry paper-insulated communications cables, the insulation resistance for each conductor shall be not less than 1500 L mega ohms, where L is the cable length in Kilometres. The measured resistance of each conductor shall not exceed the calculated resistance by more than 5%; the calculated value will be made available by the Engineer-in-Charge.

#### **Conduit and Trunking:**

Where conduit is cast in situ in reinforced concrete, it shall be checked for freedom from blockage and steel conduit shall be tested for electrical continuity as soon as the shuttering has been removed.

Steel conduit and bus duct systems shall be inspected and tested before any wiring is installed; under floor ducting shall be inspected and tested before screeding.

#### **Earth Electrodes:**

The resistance of each earth electrode, whether for earthing of protective conductors, lightning protection or an electrical system, shall be checked immediately after installation of the electrodes and the results submitted to the Engineer-in-Charge.

#### **Earth Fault Loop Impedances:**

The measured earth fault loop impedance for each circuit shall be checked against the maximum value as indicated.

Where the maximum value is exceeded the Engineer-in-Charge shall be informed.

#### **Records and Certificates:**

Inspection and test results shall be recorded on the forms provided by the Authority. Two copies shall be submitted to the Engineer-in-Charge within 7 days of each test.

When all inspections and tests results are satisfactory, a Completion Certificate and an Inspection certificate shall be given to the Engineer-in-Charge not later than the date of completion of the works. The certificates shall be given in the form laid down in the IEE Wiring Regulations for electrical installations and BS 5266 for emergency lighting systems.

The values of prospective short-circuit current and earth fault loop impedance at the origin of the installation shall be recorded on the Inspection certificates.

### **LT PANELS**

#### **Scope:**

The scope of this section covers design, manufacture, supply/installation, testing and commissioning of Power Distribution Panels including ACBs/ MCCBs/ MCBs rated upto 1000 volts. The panel should conform to IS 8623 and other relevant code.

#### **Electrical Characteristics of Factory Built Assemblies:**

When the components are mounted in the enclosures, appropriate derating factors shall be allowed for the effect of other components and interconnections.

### **Enclosures of Factory Built Assemblies:**

Unless otherwise indicated, enclosures shall provide a minimum degree of protection of IP 52 when located within buildings and IP55 when located outside building..

Door shall have adequate fastenings with provision for locking in the closed position.

Fixing holes for equipment may be inside or outside the enclosure.

Earthing terminals shall be fitted to each enclosure, suitable for internal and external connection to enable the exposed conductive parts of the protective conductor.

Where the enclosure has a painted finish, provision shall be made for earthing terminal to be electrically connected to the enclosure without need to remove any paint from ferrous metal.

Cable terminals shall be suitable for the number, size and type of cables as indicated. Adequate spacing shall be allowed for spreading of cable tails to avoid stress on the insulation or terminals; if necessary, extension boxes shall be fitted to standard enclosures. Terminals for neutral conductors for three phase and neutral circuits shall be the same size as for phase conductor, except where reduced section neutral cable cores are indicated.

2 Nos. of Gland Plates for cable entry made of 3 mm thick CRCA sheet, complete with required Knock Outs shall be provided at top or bottom with number and size of knock outs to be sufficient for the incoming and outgoings as specified in the panel details as per site conditions.

Metallic enclosures for location within buildings shall have a stove dried painted finish of the manufacturer's standard colour, unless otherwise indicated. Ferrous parts shall be degreased and adequately rust protected immediately prior to painting.

The compartment door shall be interlocked mechanically with the switch so that the door cannot be opened unless the switch is in OFF position. Means shall be provided for releasing this interlock at any time.

All MCCBs shall be provided with Rotary handle on the front door unless specifically mentioned otherwise.

### **Construction:**

#### **Basic Structure:**

All electrical panels will be fabricated from 1.6mm to 2mm thick CRCA sheet steel for robust construction properly supported with angles and channels.

Panels shall be totally enclosed, dust and vermin proof, fully compartmentalized, cubical design modular construction. The covers and doors shall be very well gasketted with neoprene rubber gaskets so as to obtain dust proof enclosure.

The cubicle will be floor-mounted type unless specified otherwise.

The cabinet will be welded construction and not of jointing construction.

Doors:

Door shall be made of 2mm sheet steel, with foamed seal polyurethane gasket, square section under tabular frame with punching in DIN pitch pattern.

The door will be provided with concealed hinges and panel locks of superior quality. The hinges will be union joint type to facilitate easy removal of the doors when necessary. Neoprene gaskets shall be provided beneath all doors and corners and also between adjacent sections, and on gland plates.



The doors will be provided in a similar fashion as generally provided for the outdoor cabinet, where water cannot enter in the cabinet from the door.

The door will be provided with strengthening arrangement to avoid wobbling and distortion.

Wherever the doors are opened on horizontal hinges, an arrangement will be provided to latch the doors in an open condition for inspection of the wiring.

Generally meter, relays push buttons, signal lamps and control components will be provided on separate compartments for in-comer feeders only.

The circuit components will be mounted on sectionalized 3 mm thick CRCA sheet with suitable threading in the sheets to facilitate easy maintenance, future addition etc.

The panels shall be manufactured with separate busbar chamber isolated from unit feeder chambers and cable alleys, to provide extra safety for working personnel.

#### **Dimensions:**

The height of the panel will be as per the drawing but not be more than 2400 mm. Depth of the panel will not be less than 300 mm and width of the panel will be given in the particulars of panel specifications or as per actual site conditions. Shop drawings shall have to be approved by the Engineer-in-charge before fabrication is taken up by hand.

#### **Adaptor Chambers for all Cable Entries:**

Wherever necessary, sheet metal adaptor chambers with angle frame and minimum depth of 300 mm will be supplied with panel. All the covers of adaptor box will be removable type. The box can be mounted horizontally or vertically. The pattern of cable entry, wherever not specified will have to be confirmed by the manufacturer/ Supplier/ Contractor in writing after placement of order. The cable entry shall be as per actual site conditions and approved.

#### **Powder Coating Treatment:**

The cubicle will undergo the process of Powder Coating treatment to the satisfaction of the Engineer-in-Charge.

The panels shall be treated for degreasing, derusting, phosphating and passivating by adopting seven/nine tank process. As per the Indian Standard Specification. Power coating process with a final coating shall be of 80-120 microns.

The painting of panel shall be carried out in a dust free atmosphere then baked in oven.

#### **Busbars:**

The bus bars will be of Aluminium with a current density of 1.0 Amp per Sq. mm. The busbars will be insulated with heat shrinkable sleeves and properly supported. All live parts shall be shrouded by means of acrylic / steel /FRP sheets to ensure no accidental contact with live parts during maintenance and provide simultaneous inspection. The busbar supports will be designed to withstand short circuit current equivalent to 35 MVA at 415 volts. The busbars will be adequately insulated and protected to prevent accidental contact during operation and maintenance.

Non-hygroscopic SMC supports shall be used for busbar to give better mechanical and electrical strength and to ensure capability to withstand specified fault current.

#### **Insulation:**

The insulation between phases and between phases and ground of the power conductors will be made of synthetic resin board/molding, resistant to dust and dampness. All insulating material will be non-hygroscopic, fungus-proof and treated with suitable synthetic varnishes.

#### **Terminals:**

Upto 35 sq. mm cables, the terminal will be provided of clip-on type generally manufactured by M/s Elmex or M/s Technoplast and above 35 sq. mm, cable end terminals will provide of brass stud type designed of rugged construction.

**Wire ways:**

PVC extruded wire ways of required size will be provided for wiring in the control panel.

**Ferruling and colour code:**

Cabling for power circuit should be red, Yellow and blue or otherwise proper colored sleeving will be provided at both ends of cables. For control cables every conductor will be provided with the identification ferrule matching with the one in the drawing.

All power and control wiring shall be done by using thimbles ferrules of proper size and quality at both ends for identification. The wiring shall be neatly bunched for easy identification.

**Cable Termination:**

Every cable, either for control or power duty will be provided with crimped type of lugs of suitable size as specified.

All power and control wiring terminals shall be brought out in the cable Alley for easy Cable Termination.

**Cables (Internal Wiring)**

All the cables will be PVC insulated FRLS of ISI approved and reputed make. The cables will be copper conductor as specified in the drawings and will be stranded and minimum number of strands will be three. The ratings will conform to IEE regulations.

All internal wiring inside the cubicle shall be carried out with 1100V grade, PVC insulated copper wires duly ferruled at either end. The power wiring above 100A shall be carried out through the PVC insulated aluminium links.

**Earthing:**

The earth busbars should be GI/AI unless otherwise specified. Bolts to be of cadmium plated with washers. Earth busbars will be provided all around the cubicle at the bottom with duplex external earth connection arrangement.

**Cable Glands and Lugs:**

The cable glands will be of brass cone grip type. These glands will be provided for all the outgoing connections at both the ends for power as well as control circuits provided in the panel and also for the incoming cable or cables. Lugs will be crimped for termination of outgoing cable at both ends (i.e. load end and panel end) with each outgoing feeder.

**Feeder Units:**

The feeder units shall be of compartmental design comprising of cubicles assembled together and shall incorporate cubicle MCCB and MCB having rupturing capacity of minimum 25 KA and 10 KA at 440 volts respectively unless specifically mentioned.

The MCCB shall be quick break and trip free type with magnetic thermal release or as specified in the BOQ. Protection Devices shall be as specified in BOQ.

Individual MCCB (with ammeter, selector switch, CTs) small wiring where provided should be easily removable from the front of the switchboard for servicing and maintenance. The connections to MCCBs from the busbars and cables should be terminated in pressure bolted joints inside the switch contacts.

The MCCB on main LT Panel shall have ratings: 63A, 100A, 125 A, 160 A, 200 A, 250A, 320A, 400A / 630A with 35 KA (minimum) rupturing capacity unless specifically mentioned in the BOQ.

Bus bar should have sufficient mechanical strength to with stand the effects of short circuit until it can be cleared by appropriate protecting device. All busbars should be clearly marked with appropriate colour code to enable immediate identification of the phase and neutral. (Mechanical strength upto 70KA/1 Sec).

The vertical bus bar should have a number of laminations to give appropriate current rating and can be graded to suit the current rating required at each point by omitting laminations at the points of current decrease.

Arrangements should be provided to receive PVC cables either from the topside or from the bottom (as specified). End plates should be mounted inside the busbar at unit level for cables from above or below.

All sheet-steel parts used in the construction of a cubicle board should have undergone rigorous rust proofing process which must comprise of alkaline degreasing descaling in dilute sulphuric acid and a recognized phosphating process. The steel work shall be finished with powder coating paint.

The equipment when assembled shall form a neat and compact unit and shall be complete with supporting framework, mounting channels, and foundation bolts etc. and shall be designed so as to ensure complete interchangeability of components.

## **1. TRANSFORMERS OUT DOOR TYPE 11 / 0.433 KV**

- 1.1. Transformers out door type shall confirm to IS-2026 (1977) Part-I wherever applicable. Transformers fittings and accessories shall confirm to IS-3639 (1966) and transformer oil to IS-335 (1972) accept as modified herein after.
- 1.2. The transformers shall have continues maximum rating as specified in schedule 'A' of BOQ at the specified normal pressure ratio, frequency and temperature rise.
- 1.3. The transformers shall be AC, 3 phase, 50 cycles, oil immersed, naturally cooled with cooling tube, core type, suitable for indoor/outdoor installation and shall be insulated with high class materials with high dielectric strength and slow ageing characteristics, able to withstand impulse voltage laid down in IS. Winding shall be electrolytic copper.
- 1.4. Insulation and magnetic induction shall be suitable for operating transformers continuously at a voltage more than 10% as specified in schedule 'A'. The winding of transformer shall be fully insulated.
- 1.5. The transformer shall be provided with hand operated off load tap on HV side for constant KVA output so as to alter the secondary voltage of the transformer by +/- 2.5% , +/-5.0%, +/-7.5%. The off load tap changing gear shall be suitable for external operation without removing the transformer cover or lowering the oil level and shall be complete with locking arrangement.
- 1.6. Transformer tanks shall be sufficiently strong to allow transformer complete with oil and tank, to be transformer by rail, road, jacked or lifter without causing deformation or leakage and shall be provided with external tubes. Care shall be taken to ensure that the joints between the tubes and tubes and body of tank are oil tight. The transformer shall be provided with four solid cast steel bi-directional reversible, detachable rollers to facilitate transporting the transformers to another point from its point of installation. The transformer shall be provided with approved arrangement of lugs suitable for lifting transformer with necessary fittings.

- 1.7. The transformer cover shall be so designed as to prevent the collection of moisture on any part. The tank cover shall also be fitted with thermometer pocket.
- 1.8. Each transformers shall be provided with an explosive vent fitted with diaphragm of standard material at the tank as well as at free end and shall be connected directly to main tank top and designed for certain and rapid release of any excessive pressure in the tank due to internal fault that may be generated in the transformer and in the transformer or in the cooling equipment. To prevent any dirt or insect entry inside the pipe, the free end should be fitted with a wire mesh.
- 1.9. The thermometer fitted on the transformer, shall be 150mm vapour pressure type, having range of 0 to 120 degree Celsius with reading pointer. It should be fitted with maximum temperature indicator with resetting device and alarm contacts.
- 1.10. All the valves as specified by manufacturer shall be standard type and makes. Means shall be provided to lock the valves. Every valve shall be provided with an indicator to show clearly purpose of the valve and directions of the rotations of rotations, open or close.
- 1.11. The transformer shall be fitted with a conservator with a filling cap, sump and suitable means of drawing oil.
- 1.12. The dehydrating breather shall be fitted to each conservator vessel and shall be complete with first fill of dehydrating agent.
- 1.13. The transformer on HT/Lt each side shall be fitted with disconnecting chamber complete with HT/LT cable boxes and their bushings, jumpers etc. so that if the transformer becomes faulty, it can be taken out easily without opening the connections from cable boxes and faulty transformer replaced and connected in minimum possible time. The tenderer shall submit along with the tender constructional details of disconnecting chamber, proposed by him in the tender.
- 1.14. The outdoor transformer shall be provided with stud in porcelain bushings (with arcing horns) on HT side. A suitable box shall be provided in LT side.
- 1.15. The outdoor thermometer fitted on the transformer shall be of 100mm dia dial, vapour pressure type having a range of 0-120 degree Celsius with reading pointer. It should be fitted with maximum temperature indicator with resisting device.
- 1.16. Earthing terminal shall be provided on the tank cover and on the tank for earthing purpose. Terminals on the tank cover and tank shall be suitable for connections to the earthing strip of GI flat 25x6mm.
- 1.17. Oil gauge should be provide for indicating clearly to an observer standing at floor level in case of indoor transformers and on the platform in case of outdoor transformer, the oil level in the conservator tank. Tap shall be fitted with oil level gauge for the purpose of drawings of any quantity of oil.
- 1.18. Transformer shall be factory painted as per standard practice and as approved by PM USIDCL. The tender shall submit complete technical details and specifications along with make and illustrated pampholt and test report of transformer to PM USIDCL for obtaining his approval of the make before incorporation in the work.
- 1.19. Cost of transformer oil shall be deemed to be included in the rates quoted in the Schedule of BOQ.
- 1.20. Transformer data sheet to be supplied as per following data, and detail data sheet vector diagram sheet should be on transformer body:-
  - (a) Markers name
  - (b) Type of rating
  - (c) No load loss
  - (d) Full load loss at 75 winding temperature
  - (e) Efficiency at 50% load
  - (f) Efficiency at 75% load
  - (g) Efficiency at 100% load
  - (h) Voltage regulation at 50% load
  - (j) Voltage regulation at 75% load

- (k) Voltage regulation at 100% load
  - (l) Details of transformer core
  - (m) Details of windings and installations
  - (n) Size and weight / volume of the unit controller.
  - (o) Drawings showing transformer completion details.
  - (p) Dimensioned sketch of various fittings & fixtures
  - (q) Oil content.
- 1.21. **TEST CERTIFICATE:-** Manufacturer test certificate shall be furnished by the contractor in original for the transformer clearly indicating that the transformer is strictly as per specifications mentioned in these documents.
- 1.22. The transformer outdoor type included under this tender shall satisfy the following conditions and cost quoted by the tenderers is deemed to include the cost of all items required to achieve such conditions.
- 1.23. The transformer shall conform to above IS specifications. The make shall be of KIRLOSKER /ABB/SCHNEDER/ECE as approved by Engineer-in-charge.
- 1.24. Transformer should be BEE rating not less than 3 star.

## **2. TESTING OF TRANSFORMERS**

- 2.1 Routine tests as per IS-2026(1977) shall be carried out and results shall be recorded. Following tests are required to be conducted:-
- a) Winding resistance
  - b) Ratio test
  - c) Polarity test
  - d) Phase relationship
  - e) Impedance voltage
  - f) No load loss and current
  - g) Load loss
  - h) Insulation resistance
  - i) Induced over voltage withstand
  - j) Separate source voltage withstand
  - k) Magnetic balance of core
- 2.2 The manufacturer shall also specify which test out of above can only be done at manufacturer's workshop and accordingly PM or his representative shall be present and record the test at manufacturer's workshop. When the transformer is ready, the contractor shall inform the PM 15 days advance that the transformer is ready for testing at the works and the PM or his representative shall witness the test at manufacturer's workshop.
- 2.3 **COMMISSIONING TEST:** Contractor shall arrange all instrument at his own cost for conducting test at site on arrival on commissioning of the transformer. The tests are:-
- (a) **Inspection on arrival :-** The transformer shall be visually examined for any sign of damage.
  - (b) **Ratio test:-** This test is carried out by ratio testing equipment called " Ratio equipment".
  - (c) **Winding resistance test:-** This test is carried out by Wheat stone bridge or preferably on Kelvin Bridge. Temperature rise of transformer can be worked out & compared with the result.
  - (d) **No load loss and current :-** The power consumed by the transformer when normal voltage is applied to the primary when secondary is open. The maximum variation permissible for the guaranteed figures of non load loss is 10%. The existing current on no load shall vary between 4% and 10% depending upon design.

- (e) **Insulation resistance:-** This is measured with 2500 volt megger cell operated and value between HV to LV, HV to earth & LV to earth measured value shall not be less than 2000 m ohm.
- (f) **Magnetic balance of core:-** This can be done in Delta/ Star transformer only. On secondary side (LV side RYBN), a voltage of 230/400 volts is injected between RN and voltage between YN & BN is measured and similarly voltage of 230/400 is injected between YN & voltage between RN & BN is measured. This test is also repeated by applying voltage between BN & voltage measured between RN & YN. The ideal results are given as under:-  
RNV, YN2/3V, BN1/3V  
RNV/2, YNV, BNV/2  
RNV/3, YN 2V/3, BN V
- (h) **Dielectric strength of oil:-** The dielectric strength of oil shall not be less than 60KV. In case it is less than 60KV the contractor at his own cost shall arrange dehydrating machine and the machine to run till the dielectric strength of 60KV is achieved.

### **3. GUARANTEE FOR TRANSFORMERS**

- 3.1 If during the defect liability period should be one year. The transformers becomes defective on any account, the contractor shall get it repaired / rewound from the manufacturer at his own cost( Partial rewinding shall not be acceptable) and complete details of repairing will be furnished to check that the transformer has been repaired satisfactorily. PM will detail his representative to check extent of damage and jointly record the repairs to be carried out. All tests shall be carried out as for original transformer at factory as well as at site. In case core of the transformer is damaged, the contractor at his own cost shall arrange for replacement of transformer.

### **4. STEEL TUBULAR POLES/STRUTS**

- 4.1 Steel tubular poles shall comply with the requirements of IS- 2713 (PART I TO III) 1980 ultimate tensile strength of the steel sheet of the pole shall be minimum 42 Kg/Sqmm. The poles/ struts are to be vertically swaged, made of seamless or welded tubes. The poles shall be well finished, clean and free from harmful defects, truly straight, smoothed and cylindrical. Cast iron base plate, finial taper plugs, screws and bolts etc shall also conform to dimensions given in the Appendix 'c' to IS-2713 (part I to III) 1980. the various dimensions of the poles, planting depth, weight etc shall strictly conform to above IS and as directed by the Engineer in charge .
- 4.2 The poles/struts shall be painted with two coat of black bituminous paint though out the entire length on the inside and up to the planting depth on the outside, either at manufacturer's workshop or at site. The remaining portion shall be painted with one coat of red oxide primer & one coat of aluminium paint before erection and one coat of aluminium paint after erection as directed by the Engineer in charge.
- 4.3 The poles shall be erected with due care so that they are truly vertical and shall be suitably stayed till the concrete in foundation is set.
- 4.4 The location of poles and struts shall be as directed by the Engineer in charge
- 4.5 Strut/ poles shall be chamfered at the top so as to rest on the pole squarely and shall be secured by clamps as shown on drawings. The distance between the pole and strut shall not be less than 1.8 meters at the GL.
- 4.6 The concrete in the foundations for poles & struts etc shall be PCC 1:4:8 and in the plinth blocks shall be PCC 1:3:6 type . the plinth blocks shall be finished fair and even with 12 mm thick plaster in CM 1:6.

### **5. STAY ASSEMBLY & STAY WIRES**

- 5.1 The stay shall be fixed to stay rod at the bottom and to the stay clamps to the poles by means of well spliced joints with a porcelain guy insulator & a turn buckle inserted in the middle and near the top respectively. The stay clamps shall be located near about the centre of gravity of the pull of the over head conductors. The clamps shall be made out of 50 X 6 mm flat iron and shall be fixed with a 6 mm dia bolts, nuts and washers.
- 5.2 Cross arms shall be made of MS channel of size ISMC 75 X 40 mm or an other appropriate size as approved by Engineer in charge at site or as shown on drawings. These shall be made to shape as show on drawings and shall be fixed to poles with clamps made to shape out of 50 x 6 mm flat iron and two nos 16 mm dia bolts , nuts washers etc. as shown on drawings and directed by engineer in charge . edges of clamps and cross arms shall be finished smooth. Holes shall be drilled for insulator bolts and other bolts as required.
- 5.3 The cross arms shall be shaped properly fit the steel tubular poles. For proper clamping MS round 6 mm dia hooks, made to shape for running earth wire / wires of suitable clamps as shown on the drawings shall be provided.

## **6. INSULATORS**

- 6.1 Insulators and insulator fittings shall comply with the requirements of IS – 731 of 1971 (second revision), IS -2486 PART I

## **7. PAINTING TO STEEL WORK**

- 7.1 Exposed surfaces of all steel work shall be painted with two coat of aluminium paint over a coat of red oxide or zinc chromate primer.

## **8. LIGHTENING ARRESTORS**

- 8.1 Lightening arrestors shall be non- linear type and shall comply with IS-3070-1974 (Part I). These shall be provided all as per BoQ.

## **9. EARTH WIRE**

- 9.1 Earth wire shall be 4mm nominal dia (8SWG) GI wire and shall run continuously as shown on drawings and as directed by engineer-in-charge.
- 9.2 The earth wire shall be laid in such a manner that it is free from kinks and is properly secured to hooks/ clamps by clip or eye hooks or binding wire as required. The sag for the same shall be as that of main conductors.
- 9.3 Every cross arm shall be properly bound to the continuous earth wire.

## **10. GANG OPERATED AIR BREAK SWITCHES ( SWING OUT EXPULSION FUSE ISOLATORS)**

Gang operated air break switches (swing out expulsion fuse isolators) shall be of 3.3 KV, 6.6 KV, 11 KV, and 33 KV. Rated up to 400 amps as indicated. They shall be three pole type. 3 insulators per phase. Triple pole rocking, out –door type, gang operated, suitable for both horizontal and vertical mounting with the following components:

- (a) channel bases for mounting post insulators.
- (b) Operating mechanism complete with 5/6 m long operating pipe. Phase coupling shaft, operating handle with padlock arrangements but with out padlocks.
- (c) Easy replacement type MS arcing horns with mark first and break after features.
- (d) Multi-built type contacts will be provided to grip incoming and outgoing ACSR conductors.
- (e) None – ferrous parts shall be electroplated and ferrous parts hot dip galvanised. These should be installed as directed b the engineer-in-charge.

### **10.1 Service Fuses**

Service fuses shall conform to IS- 2086-1982 and shall be suitable size for entry to ends to ends of lines jointed to them. They shall be fixed at the pole end of the service line except when otherwise directed.

## **DG SET**

### **5.1 BED FRAME AND COUPLING**

**Bed (Base) frame shall be factory made fabricated by the manufacturer of DG Sets out of MS rigidly welded, robust construction suitable for mounting the diesel Engine and couple, alternator comprising of following: -**

- (i) **Steel section bed plate duly ribbed.**
- (ii) Foundation bolts, nuts, washers and antivibration pads.
- (iii) Flexible coupling.
- (iv) Drip tray.
- (v) Protective spider/screen coupling guard.

### **5.2 DIESEL ENGINE FOR GENERATING SET**

It shall conform to BS 649/5514 or IS-1601 or 'DIN'-A-6720 and shall be of adequate capacity to deliver the electrical output at peak summer conditions prevailing in the area. Engine shall be direct injection, 4 stroke, vertical in line, V-type multicylinder, cold starting, water cooled, radiator type, stationery design, with specific shaft output/HP when operating at a governed speed of 1500 RPM and under NTP conditions suitable for continuous duty generating set applications. It should also have an additional 10% overload capacity for one hour in any period of 6 hours of continuous operation at standard operating conditions. The engine shall be supplied complete with all the standard accessories and fittings as under: -

- (i) Fly wheel to suit flexible coupling, complete with fly wheel/housing complete with starter gear ring and flexible coupling.
- (ii) Engine cooling system i.e. radiator and fan (contractor to submit the details of cooling arrangement proposed to be provided).
- (iii) Air cleaner dry type.
- (iv) Starting equipment mounted on engine consisting of Electric starter motor 24 V/12 VDC dynamo and voltage regulator automatic as per recommendations of the manufacturer.
- (v) Sufficient Nos of batteries of 25 plates each 12 volts 135 ampere hour, heavy duty lead acid, storage type connected in series or as required.
- (vi) Set of battery leads with robust brass terminals.
- (vii) One No. battery charging alternator 24 volts DC.
- (viii) Fuel and lubricating oil filters.
- (ix) Fuel hoses.
- (x) Fuel pump PTR type.
- (xi) Mechanical governor.
- (xii) Lubricating oil pump.
- (xiii) Corrosion resister.
- (xiv) Industrial exhaust silencer.





motor) panel to be suitable for single running, manual operation rated for system output and incorporating the following devices/instruments mounted flush on the panel as directed: -

- (i) One digital voltmeter 0-500 volts AC with 4 way selector switch of reputed make.
- (ii) One digital ammeter AC of suitable range with 3 Nos current transformers of suitable ratio and accuracy class-I with four way selector switch of reputed make.
- (iii) One No frequency meter load type/vibrator type.
- (iv) One set of bus bars of suitable capacity.
- (v) 2 sets of indicating lamps, 230 volts one for 'Set running' and other for 'Set on load'.
- (vi) Three Nos instruments fuses HRC/ MCB type 6 Amps.
- (vii) Two Nos push buttons for ON/OFF operation.
- (viii) One No neutral link bolts.
- (ix) Two Nos earthing studs.
- (x) Power factor meter.
- (xi) Cold starting arrangement (as applicable).
- (xii) Audio visual annunciation standard 3 points LOP/OS/HWT annunciation for faults as such as low lub oil pressure, high water temperature and over speed in case it is provided by the manufacturer.
- (xiii) Standard circuit diagram plate.
- (xiv) Suitable opening with cable glands for incoming and out going cables.
- (xv) Ampere/volt meter will be of flush type make AE, EE, KAY, HAVELLS, HPL, LEGRAND.
- (xvi) Push button shall be of make L and T, KAY and LEGRAND.

### **5.5 FUEL TANK**

Fuel tank shall be rectangular free standing, floor/wall mounting type made of sheet and of capacity to hold diesel oil sufficient for 12 hours running at full load The tank shall be provided with following: -

- (i) Level indicator to indicate level in the tank.
- (ii) Drain plug with 2 meters long pipe for draining out.
- (iii) Piping for fuel and spare length of pipe of 3 meters.
- (iv) Fuel strainer at inlet.
- (v) One air vent and one air breather.

## **5.6 GENERAL**

DG sets will be turbo type of suitable capacity described in BOQ. The contractor will procure all the three major component of DG sets i.e. Engine, alternator with control panel and base plate from one manufacturer as per BOQ and will produce purchase voucher/challan of the company to the Engineer-in-Charge for satisfaction before payment is made to him for these items. Procurement of items mentioned above from different sources and sponsoring shall not be accepted.

## **5.7 GENERAL ARRANGEMENT**

The diesel engine and alternator shall be directly coupled by means of a specially designed flexible coupling or as per manufacturer in order to form a very compact arrangement and both the units including the radiator assembly shall be mounted on a rigid fabricated bed plate (base frame) suitably machined to ensure perfect alignment of both the machines and of rigid construction to ensure minimum vibration. The base frame shall also be provided with lifting facilities and predrilled foundation holes suitable for permanent installation on prepared concrete foundation. The foundation, bolts, and grouting thereof shall be specified by the manufacturers/set builders.

## **5.8 TESTING**

- 5.8.1 All routine test certificates from the manufacturer in respect of the diesel engine, alternator and the control panel will be made available by the contractor.
- 5.8.2 The Generating set shall be run for a period of 6 hours running after commissioning of work
- 5.8.3 All instruments, equipments, materials including DHPP and Engine oil and labour required for testing will be made available by contractor at his own cost and unit rate in BOQ will be deemed to be included for testing to the entire satisfaction of the Engineer-in-Charge: -
- (i) Insulation resistance test on the alternator and control panel.
  - (ii) High voltage test as per BS-2613 clause 33 on the alternator when still hot.
  - (iii) Efficiency test at rated load and over load.

The electrical output in terms of KW from the above observation will be worked out and compared to the output indicated by the manufacture for assessing the performance. The observations in respect of cooling temperature, oil pressure etc, made during the test shall be compared with these laid down by the manufacturer to ensure that the set is performing within the designed conditions. Attention shall also be paid to the foundation/fixing, to ensure that there are no undue vibrations in the set.

- 5.8.4 All the expenses included on above tests including provision of testing apparatus required to carryout above mentioned test shall be borne by the contractor without any extra cost of Government. If the results of test are not found satisfactory, the contractor shall at his own expense replace the defective equipment/materials or any part thereof as directed by the Engineer-in-Charge. The decision of the Accepting Officer shall be final, conclusive and binding in this respect.

5.8.5 The test as described above under clause 5.8 shall be carried out in presence of electrical inspector/IEM nominated by Accepting Officer.

## **5.9 COMPLETION**

After test, the installation will be approved and accepted by Engineer in charge in writing. The installation will be taken over provisionally for one month and if no defect noticed during one month period, the final completion certificate will be issued. If there is found any defect during one month period, the contractor will repair it and installation will again be taken provisionally for one month. Maintenance period for one year will start from the date of final completion certificate which is issued after one month of his satisfactory working from the date of provisional take over.

## **5.10 TRAINING OF STAFF**

The contractor will give training to User staff as detailed by Engineer-in-Charge for 03 days period regarding operating and running maintenance of generating set.

## **6. GUARANTEE**

The contractor shall ensure that the generating set, panels, electrical fittings/accessories etc under this contract, shall be of best quality and shall be strictly in accordance with specifications and particulars contained/mentioned in the clause thereof and the contractor shall guarantee that the said generating set will continue to confirm the description and quality aforesaid for a period of 12 months. Engineer-in-charge may have inspected or approved it. If during the aforesaid period of 12 months the said generating set, articles are discovered not to confirm the description, quality, type aforesaid or have deteriorated and the decision of Engineer-in-charge in that matter will be final conclusive and binding the rejected item will be replaced by the contractor free of cost.

## **7. PAINTING**

Electric control panel shall be factory made and duly painted, having under gone a rigorous rust proofing process, treated with high corrosion resistant primer and finally painted with rust proof synthetic enamel paint of gray tint.

8. (i) The tenderer shall supply in duplicate technical pamphlets and literature for the generating set, its components/accessories, ACB's, auto synchronizing panel offered by them along with his offer.
- (ii) The tenderer shall also supply complete layout/schematic drawing showing portion of DG sets, panel and other equipment to be accommodated in existing room based on his own design in accordance to the best Engineering practices along with his offer.

## **9. CATALOGUES**

- (a) The tenderer shall supply the following literature after acceptance of tender to the Engineer-in-Charge.

- (i) Manufacturer's instructions/Books on maintenance and operation of the plant – 2 Sets.
- (ii) Spare parts catalogue of each of the units of plant – 4 Sets.
- (b) The tenderer shall supply the literature giving technical information of equipments offered by him – 2 Sets.

## **10. LAYOUT PLAN**

The contractor shall submit to the Engineer-in-charge layout plan, in triplicate duly signed by contractor and Engineer-in-Charge showing actual position of DG set, fuel tank, electric control panel, change over switch, batteries etc, and all other information that will be necessary for record, maintenance and operation. The contractor shall also submit sufficient copies of the recommended design of foundation for DG set supplied by the manufacturer/set builders.

- 11.1 Earthing shall be as per IE regulations and as per recommended by manufacturer.
- 11.2 The earth plate shall be of cast iron galvanised of size 600x600x6.3mm thick, placed vertically and shall be surrounded with adequate quantity of the charcoal dust to a packed thickness of 15cm on all sides GI strip as per BOQ, riveted/soldered to the GI earth plate shall run up on the metallic bodies of electrical equipments/provided with 50mm dia and shall be GI pipe and plug and socket pipe for leading and protecting earth conductor, upto the building. Pipe shall be 50mm dia, light grade. The metallic bodies of DG set and connected metal works shall be electrically connected at two points to earth by means of GI strips and shall be fixed over the entire length on floors/walls or in duct by GI clamps/clips, saddle, staple etc. (at every one meter centre to centre) which shall not in any way damage the earthing strips. The contractor shall get the layout of the earth strips and positions of proposed earthing pits approved from Engineer-in-Charge before installing the same.
- 11.3 The charcoal dust and returning filling shall be done in layers not exceeding 15cm thick and shall be properly watered and rammed. Surplus spoil shall be disposed off upto a distance not exceeding 150 meter and site left clean and tidy on completion.
- 11.4 The ultimate depth of earth electrode would depend on the nature of soil and contractor is required to take it to depth where sufficient moisture exist and natural conditions are suitable for resistance as specified here-in-after.
- 11.5 As far as possible joints in the GI/Cu earthing strips shall be avoided. But wherever it is absolutely necessary, prior permission of Engineer-in-Charge will be obtained in writing. While jointing, strip shall be properly cleaned, straight joint shall overlap 50mm. All joints in GI/CU strips shall be riveted (using 6mm dia GI rivets in two rows with 2 Nos rivets in each row) and then welded on all the four sides to full length of the joint.
- 11.6 Concrete for PCC chamber shall be 1:3:6 type C-1 cement concrete using 20mm graded coarse stone aggregate. Funnel in the chamber shall be provided as given in plate No 5 mentioned above and be provided with wire gauge of 0.45 mm nominal dia and 1.18mm average width of aperture.
- 11.7 The cover and frame for earth pits shall be of cast iron. The cover and frames shall be painted (all over) with 2 coats of black bituminous paint.

## MODULAR VRF SYSTEM

### 1. GENERAL

Unit shall be air cooled **Heat Pump type, Variable refrigerant Flow** air conditioner consisting of outdoor units and multiple indoor units, each suitable to cool in summer/ heating in winter as per the requirements.

- 1.2 The refrigerant piping shall be extendable up to 150 m with 50 m level difference without any oil traps.

### 2. OUTDOOR UNIT

**2.1 The outdoor unit shall be a factory assembled unit housed in a sturdy weather proof casing constructed from rust-proofed mild steel panels coated with a baked enamel finish.**

**2.1.1 The outdoor unit shall have multiple scroll compressors all compressor should have vapor injection technology. At least one compressor in each module should be of digital vapor injection type.**

**2.1.2 The connectable range of indoor units shall be based on heat load calculations.**

**2.1.3 The noise level shall not be more than 68 dB(A) at normal operation measured horizontally 1m away and 1.5m above ground.**

- 2.2 The outdoor unit shall be modular in design and shall be allowed for side by side installation.

### 3. COMPRESSOR

**3.1 The compressor shall be of highly efficient hermetic Digital Vapor Injection Scroll capable of capacity modulation by time averaging**

**method & Vapor injection Technology. Each ODU should have minimum 1 no. variable compressor upto 20 HP capacity, 2 nos. variable compressors upto 40 HP capacity, 3 nos. Variable compressors upto 60 HP capacity & 4 nos. variable e compressors upto 80 HP capacity.**

4. **HEAT EXCHANGER**

**4.1 The heat exchanger shall be constructed with copper tubes mechanically bonded to aluminium fins to form a cross fin coil. The aluminium fins shall be covered by anti-corrosion resin film. The System must have sub-cooling heat exchanger further to Condenser to increase refrigerating effect in Indoor units. The Condenser fins must be coated with Anti-corrosive treatment.**

5. **REFRIGERANT CIRCUIT**

- 5.1 The refrigerant circuit shall include an accumulator, liquid and gas shut off valves and a solenoid valves or pulse width modulation valve.
- 5.2 All necessary safety devices shall be provided to ensure the safety operation of the system.

6. **SAFETY DEVICES**

- 6.1 The following safety devices shall be part of the outdoor unit;  
High Pressure Switch, Low Pressure Switch, Fan Motor Safety Thermostat, Over Current Relay, Fusible Plugs, Fuses.

7. **OIL RECOVERY SYSTEM**

- 7.1 Each unit shall be equipped, with an oil separator to ensure stable operation with long refrigerant piping.

8. **INDOOR UNIT**

**8.1 Indoor unit shall be mix-match of wall mounted type, Slim 1Way Cassette Type, Mini 4Way Cassette Type, 4Way Cassette Type, Slim Duct Type or MSP Duct Type as specified in scope of work. It shall have electronic control valve to control refrigerant flow rate in response to load variations of the room. The fan shall be of the dual suction multi blade type and statically and dynamically balanced to ensure vibration free operation.**

**8.2 The address of the indoor unit shall be set automatically in case of individual and group control. In case of centralized control, liquid crystal remote controller shall set it.**

9. **CENTRALIZED SYSTEM TOUCH SCREEN REMOTE CONTROLLER (OPTIONAL)**

- 9.1 A multifunctional compact Touch Screen centralized controller shall be provided with the system.
- 9.2 The System Controller shall act as an advanced air conditioning management system to give complete control of VRV/VRF air conditioning equipment. It shall have ease of use for the user
- 9.3 It shall be able to control up to 256 groups of indoor units with the following functions :-
- 9.3.1 Starting/stopping of Air conditioners as a zone or group or individual unit.
- 9.3.2 Temperature setting for each indoor unit or zone.
- 9.3.3 Switching between temperature control modes, switching of fan speed and direction of airflow, enabling/disabling of individual remote controller operation.
- 9.3.4 Monitoring of operation status such as operation mode & temperature setting of individual indoor units, maintenance information, trouble-shooting information.



**9.4**

**The controller shall have wide screen user friendly colour LCD Touch scree display and can be wired by a non polar 2 wire transmission cable to a distance of 1 km. away from indoor unit.**

**10 REFRIGERANT PIPING**

11.1 All refrigerant piping for the air conditioning system shall be constructed from hard drawn seamless copper refrigerant pipes with copper fittings and silver-soldered joints. The refrigerant piping arrangements shall be in accordance with good practice within the air conditioning industry, and are to include expansion valves, charging connections, suction line insulation and all other items normally forming part of proper refrigerant circuits.

11.2 The suction line pipe size and the liquid line pipe size shall be selected according to the manufacturer's specified outside diameter. All refrigerant pipes shall be properly supported and anchored to the building structure using steel hangers, slotted angle tray, anchors, brackets and supports which shall be fixed to the building structure by means of inserts or expansion shields of adequate size and number to support the load imposed thereon.

11.3 The OD & wall thickness of copper refrigerant piping shall be as follows:

Size	Thickness	Specification
6.35mm (1/4 in)	24 G	C1220T-O (ANNEALED)
9.52mm (3/8 in)	24 G	C1220T-O (ANNEALED)
12.70mm (1/2 in)	22 G	C1220T-O (ANNEALED)
15.88mm (5/8 in)	22 G	C1220T-O (ANNEALED)
19.05mm (3/4 in)	20 G	C1220T-1/2 H (HALF-HARD)
22.23mm (7/8 in)	20 G	C1220T-1/2 H (HALF-HARD)
25.40mm (1 in)	20 G	C1220T-1/2 H (HALF-HARD)
28.58mm (1 1/8 in)	18 G	C1220T-1/2 H (HALF-HARD)
31.75mm (1 1/4 in)	18 G	C1220T-1/2 H (HALF-HARD)
38.10mm (1 1/2 in)	16 G	C1220T-1/2 H (HALF-HARD)
44.45mm (1 3/4 in)	16 G	C1220T-1/2 H (HALF-HARD)
50.8mm (2 in)	14 G	C1220T-1/2 H (HALF-HARD)

**11. DRAIN PIPING**

- 11.1 The indoor units shall be connected to drain pipe made of hard PVC.
- 11.2 The pipes shall be laid in proper slope for efficient drainage of condensate water.
- 12.2 **DRAIN PIPE INSULATION**
- 12.1 Drain pipes carrying condensate water shall be insulated with 6 mm Nitrile rubber having a 'K' value of 0.037 W/mk at a mean temperature of 20°C and a minimum density of 55 Kg/Sqm.
- 12.2 The joints shall be properly sealed with synthetic glue to ensure proper bonding of the ends.
- 13. **PIPE INSULATION**
- 13.1 **REFRIGERANT PIPE INSULATION**
- 13.1.1 The whole of the liquid and suction refrigerant lines including all fittings, valves and strainer bodies, etc. shall be insulated with 19mm /13 mm thick Nitrile close cell rubber.
- 13.1.2 The joints shall be properly sealed with synthetic glue to ensure proper bonding of the ends.

## **12 KW<sub>p</sub> PV Grid Connected solar power plant**



1	Project	:	12KWp grid system for SPV system
---	---------	---	----------------------------------

2	Plant Capacity	:	12 kWp
3	Source of Energy	:	Solar
4	Process	:	PV Technology
5	Project Timeline	:	NIL
6	Battery Bank	:	180Ah/ 48 V

### **System Description**

S.No	Parameters	Plant Capacity 2.5 kWp
1	Solar PV modules	345 Wp each
2	Voltage Range	250-800 V
3	Total number of Modules	36
4	Modules Connected in series	18
5	No of Parallel Strings	1 per each inverter
6	Solar Inverter	12 KVA
7	No of Distribution Box	1

### **Solar PV Module**

A photovoltaic module is a packaged interconnected assembly of photovoltaic cells, which converts sunlight into energy. For this project solar module of Poly crystalline is considered. The modules being offered are IEC 61215 Ed 2 certified.

#### **Solar PV Module technical specification**

Parameters	Specification
PV Module Capacity	345 Wp
PV Module type	Poly crystalline
Total No. of PV cell per Module	36
Mounting arrangement for solar module	On Module mounting structure
Cable gland at module Junction Box	Yes

Standard/Approvals from National/International	IEC 61215-Ed2 & IEC 61730-1 72
Mechanical Features	
Toughened	Yes

Low iron content	Yes
High transmissivity from glass	Yes
Anodized aluminum frame	Yes

### **Module Mounting Structure**

The module mounting structure is designed for holding suitable number of modules in series. The frames and leg assemblies of the Module Mounting structure are manufactured using standard Mild Steel sections of angle, channel, tubes and any other sections conforming to IS: 2062 and hot dip galvanized.

#### **Structure Technical Specification**

Parameters	Specifications
Type	Fixed Type using mild steel with hot dip galvanized coating of 80 micro mm
Location	Roof mounting
Overall dimension	As per design Angle (35:35: 5) approx. Channel (25: 25:5) approx.
Foundation	PCC (1:2:4)

### **Solar Inverter**

S.No	Parameters	Specifications
1	Model	12 KVA Ongrid Power Conditioning Unit
	<b>INPUT (DC)</b>	
3	Max. recommended PV power	12 kWp
4	Nominal power	12 KW
5	Voltage range	250-800 V
	<b>OUTPUT (AC)</b>	
9	Voltage range	230 V ( $\pm 20\%$ ) + N + PE
11	Nominal frequency	50/60 Hz
12	Total harmonic distortion (THD)	< 3 % @ nominal apparent power
13	Max. efficiency	98 %
14	Operating temperature	-20 ... +60 °C
15	Humidity	0 ... 90 %
16	Cooling	Fan (plug & play)
17	Protection degree	IP65 / IP55
18	Protection from lightning	Device inbuilt for Protect from Surge arrester

### **Junction box**

In the Junction boxes, individual module strings are bundled and safely routed to the inverter. Junction boxes will have suitable cable entry points fitted with cable glands of appropriate sizes for both incoming and outgoing cables.

#### **Junction Box Technical Specifications**

<b>Parameters</b>	<b>Specifications</b>
Type	FRP / ABS /Polycarbonate
Construction	Dust, Water & Vermin proof
Earthing Provision	Provided
Hardware	Provided as required
Mounting	Structure Mounting

### **Earthing**

The array structure of the PV yard will be grounded properly using adequate number of earthing set. All metal casing / shielding of the plant shall be thoroughly grounded to ensure safety of the power plant.

### **Cable**

Used copper cable of solar grade with proper conducting around it. Cable sizing design is done as per IEEE standards of keeping wiring loss under 3%. In solar PV system, wire size selection as per site 2.5 kw/3 kw solar system.

#### **Cable Specifications**

<b>Parameters</b>	<b>Specifications</b>
Type	PVC insulated and Sheathed
Make	Polycab / HPL / Havells / Finolex / RR Kable
Material	Copper
Test voltage	650V/1.1kV
Color	Red, Black, Blue
Temperature	-15 Deg C to +70 Deg C
Standard	IS 1554 / 694-1990

#### **Battery Bank Specification**

<b>S. No</b>	<b>Specification</b>	<b>Rating</b>
1	Capacity	180Ah
2	Voltage	12 V

<b>DRAWINGS AND DOCUMENTS BY CONTRACTOR:</b>
--

**Extent of Provision:**

Unless otherwise indicated, the Contractor shall provide the shop drawings and documents specified these specifications.

General layout drawings shall be drawn to a scale of 1:50 and detailed layout assembly drawings to a scale of 1:20. If more details is necessary scales of 1:10, 1:2 and 1:1 may be used.

The numbers of sets of drawings and documents to be supplied shall be as indicated.

**Shop Drawings And Documents:**

Shop drawings and documents including diagrams and schedules shall show the details of the Contractor's proposals for the execution of the works and shall include everything necessary for the following purposes:

- a). To illustrate in details, the arrangement of the various sections of the works and to identify the various components;
- b). To integrate the works with the detail of the building and other installations.

Shop drawings shall include:

- a) General layout drawings showing the location of all equipment including cable; cable tray, conduit ducting and earth electrodes;
- b) Detailed layout drawings showing the location of all equipment including cable, cable tray, conduit and ducting in switch rooms and plant rooms;
- c) Assembly drawings of factory Built equipment and site built assemblies;
- d) Detailed layout drawings showing the connection of cable and conduit to equipment;
- e) Detailed layout drawings showing the connections through ceiling voids and vertical shafts;
- f) System diagrams, circuit diagrams and wiring diagrams for all installations and equipment.

Diagrams shall comply with relevant IS. Interconnection diagrams shall indicate the type of cable, conductor size and terminal numbering.

**Builder's Work Drawings:**

Builder's work drawings shall show fully dimension details of all builders work required in connection with the works together with the overall size and weight of equipment.

Where the Engineer-in-Charge agrees, holes may be marked out on site instead of being shown on drawings.

### **As Built Drawings:**

As-built drawings, including diagrams and schedules shall show all the information necessary so that each installation can be operated, maintained, inspected and tested so as to prevent danger, as far as is reasonably practicable. They shall incorporate the information necessary for the identification of the devices performing the functions of protection, isolation and switching, and their locations. The value of prospective short-circuit current and earth fault loop impedance at the origin of the installation shall be recorded on the appropriate system diagram.

Circuit details including loading, route, destination and where buried, the depth below finished ground level shall be shown for each cable, conduit, and ducting. Conductor size and material and the type of insulation of all cables shall be shown together with the number of cores in each cable, the number of cables in each conduit, trunking or ducting. Where identification is by colour of insulation or sheath, this shall be shown. Joints and draw boxes shall be shown.

Where incoming supply cables are installed by others, they shall also be shown as described above.

Drawings shall indicate whether conduit or ducting is surface mounted, concealed in ceiling, spaces in wall chases, in floor screeds or cast in situ.

All earthing conductors, main equipotential bonding conductors, main earthing terminal or protective conductors and supplementary equipotential bonding conductor shall be identified with function, origin route, destination, conductor size and material, type of insulation and where buried, the depth below finished ground level test points shall be indicated.

Earth electrodes shall be identified to their types, dimensions, material and depth below finished ground level. The nature of the soil and any treatment that has been given to it or special fill that has been used in the installation shall be identified.

Details of each item of equipment including luminaires shall include electrical characteristics, classification, degree of protection against ingress of solids and liquids, class of protection against corrosion and manufacturer's name and reference.

Diagrams shall comply with relevant clauses of these specifications and they shall be supplemented with physical arrangement drawings to assist the location and identification of component parts of equipment.

During the course of the works, the contractor shall maintain a fully detailed record of all changes to ensure that the as-installed drawings are in all respects accurate.

Each drawing shall be in accordance with relevant IS to ensure suitability for micro-filming and shall be on durable translucent material, other than paper, of a standard size A0 to A4 in accordance with relevant IS. The words 'AS-BUILT' shall be placed in 19 mm block letters adjacent to the title block of each drawing together with the name of the site and the section of the works, the title of the installation, the date of completion of the works, the Authority's contract number and the name of the Contractor.

A draft of each as built drawing shall be submitted to the Engineer-in-Charge before final issue is made.

### **Maintenance and Operating Instructions:**

For each electrical installation, system and individual equipment forming part of the works, the maintenance and operating instructions shall include:

- a) A description of the extent and manner of operation, including duration periods of standby systems;
- b) A description of the method used for compliance with Regulation 413-3 of the IEE wiring Regulations together with time/current characteristics for all protective devices or automatic disconnection of supply.
- c) Copy of the inspection certificate and all the test records.
- d) A copy of any certificates of compliance with relevant standards or schemes as may be required.
- e) Comprehensive instructions for the switching on, operation, switching off and isolation, and for dealing with emergency conditions.
- f) Instructions for any precautionary measures necessary.
- g) Instructions for servicing, including frequency and materials to be used, to maintain the equipment in good and safe condition.
- h) The names and addresses of suppliers of all major components together with the type and model reference, serial number, duty rating and the order number and date.

Maintenance and operating instructions shall be indexed and contained in ring binders with stiff covers. The name of the site and the Authority's contract number shall be printed on the front and spine with, where more than one volume is necessary, a suitable identification title. The date of completion of the works shall be included on a flyleaf.

Copies of manufacturer's data may be incorporated to supplement the descriptions and instructions required in relevant clause but shall not replace them. Only data relevant to the works shall be included. Where non relevant data appears on the same sheet, it shall be cleared marked to show that it is not applicable. The data shall be cross referenced within the text and included in the index; if possible, it shall be contained in the ring binders, but where this is not possible, suitably protected box files or folder shall be provided, identified in accordance with relevant clause.

A draft of the maintenance and operating instruction shall be submitted to the Engineer-in-Charge before the final documents are issued.

<b>SAFETY REQUIREMENTS:</b>
-----------------------------

#### **Scope:**

Safety procedures as laid down in Indian Standards shall be strictly followed during erection and commissioning.

The safety provisions required under the IEE Rules shall be provided for which no extra payment shall be made.



<b>Additional Specifications</b>		
<b>Sr.No.</b>	<b>Name of Product</b>	<b>Description of article</b>
1.	Open Gym Equipment's	Cross walker
		Air walker
		Arm & Leg
		Strengtheners
		Air swing
		Exercising bar
		Cross trainer
		Multi-functional trainer
		Balancing beam
		Leg press
		Pull up station
2.	Pole Light	6 Meter GI Octagonal Pole (Top dia-70 mm, bottom dia- 130mm, Thickness-3 mm) Base plate size-220x 220x 12mm), 4 Light Bracket For 4 Nos. Light, Foundation Bolts 4 Nos.
3.	Fidder Pillar	Outdoor type external lighting feeder pillar of suitable size not less than 30 cm and up to 45 cm deep made out of M.S. sheet 2mm thick (14 SWG) duly compartmentalized, double door with locking arrangement (IP-54), duly fixed on MS angle iron frame work of size 50mm x 50mm x 6mm, 90 cm long legs out of which 45 cm duly grouted in cement concrete 1:2:4 (1 cement : 2 sand : 4 stone aggregate 20mm) and having following accessories mounted inside the cubical panel i/c connection, inter connection with aluminum thimbles, earthing with two nos. earth studs duly painted with one coat of red oxide & two coats of superior quality enamel paint of approved shade complete etc. as reqd. Power contactor 1 sets of single pole of suitable ratings 365 Days 24 Hrs electronic adjustable timer for on/off control of the light fittings during Summer & winter-01 nos- Legrand make or equivalent from GE / Siemens / L&T. The above board shall be complete with 1 no. phase indicating lights, flush mounted Ammeter, Voltmeter, selector switches, protective fuses etc. at Incomer with all inter connections by min. 2.5 sq.mm. Copper wires. External Lighting Feeder Pillar: - INCOMER : 40 AMP DP MCB (10 KA) BUS BAR : 100 AMP, 500 Volts, 1 phase 50 HZ 2P high conductivity electrolytic Aluminum bus bar. The current density of bus bar shall be minimum 1.00 sq mm /amp. The Maximum allowable temperature for the Bus bar to be restricted to 85 deg C. The temperature rise should be restricted to 35 deg C above ambient temperature. OUT GOINGS: 4 nos. 6- 32 AMP DP MCB (10 KA)
4.	LT Panel	Supply and installation of wall cum floor mounting totally compartmentalized cubical type switch with 125A, TP N Al bus bars, bus bar chamber, feeder module, cable compartment, castell lock, earth bus bars, voltmeters, ammeters all with selector switches, 3 phase indication lamps with fuse base and carriers, etc all inter connections ,painting and earthing as per requirement with following components: 125 A , 500 V 4P MCCB, 35KA Braking Capacity Incomer with mechanical castell interlock, voltmeters, ammeters, selector switches, indication lamps, control fuses etc; make Havells -1 nos outgoing 100 A , 500 V TP&N MCCB, 35KA Braking Capacity - 4 no 80 A, 500 VTP & MCCB,16KA Braking Capacity -2 nos ( Switchgear make C& S, Havells , Legrand) G I continuous Earth Bus

		of 25x6mm and danger board
5.	Casted pole lights	3 mtr & 4 mtr pole 2arm aluminum castcomplete with light.
6.	Yoga sculpture in metal/FRP/Stone	Fabrication and Installation of Customized Casted Brass Sculpture 2-3 mm thickness of Life size Yoga postures with Matt Lacquer Polish for Weather Protection fixed to pedestal as provided by the client, complete as per the directions of Site-in- Charge. The item is related to creative lead which will depend upon the creativity of the design consultants upon preparation of model/ prototype/ execution of item. Rate to include all necessary hardware.
		Fabrication and Installation of Customized Stone Sculpture made in Black Indian Stone 10 feet (Height) x 7.5 feet (Width) x 6.25 feet (Breath) fixed to pedestal as provided by the client, complete as per the directions of Site-in-Charge. The item is related to creative lead which will depend upon the creativity of the design consultants upon preparation of model/ prototype/ execution of item. Rate to include all necessary hardware.
		Fabrication and Installation of Surya Namaskar Life size FRP Sculpture 2-3mm thickness (12 Yoga Posture Sculpture) with Ramp pedestal made in MS Framework and cladded with FRP Textured Sheets, complete as per the directions of Site-in- Charge. The item is related to creative lead which will depend upon the creativity of the Design consultants upon preparation of model/ prototype/ execution of item. Rate to include all necessary hardware.
		Fabrication and Installation of Stone embossed Uttarakhand Tourism Logo (Signage) made on Dholpur Stone Measuring 8 feet x 5 feet x 1 feet fixed to pedestal as provided by the client, complete as per the directions of Site- in-Charge. The item is related to creative lead which will depend upon the creativity of the design consultants upon preparation of model/ prototype/ execution of item. Rate to include all necessary hardware.
7.	Stone Benches	3-seater length 7X2X2.5 ft
8.	HDPE dustbin with pole	50 L & 100 L HDPE dustbin with pole

## **SECTION 7.**

# **SECURITIES AND OTHER FORMS**

**PERFORMANCE BANK GUARANTEE**

**(Refer Clause 58, Section-3 GCC)**

To,

\_\_\_\_\_ [name of Employer]

\_\_\_\_\_ [address of Employer]

\_\_\_\_\_ [name of Contractor]

WHEREAS .....[name and address of Contractor] (hereafter called “the Contractor” that undertakes in pursuance of LOA Nos. .... dated..... to execute ..... [name of contract and brief description of works].

AND WHEREAS it has been stipulated by you in the said contract, that the contractor shall furnish you with a Bank Guarantee by a recognized Bank for the sum specified therein as security for compliance or his obligation in advance with the contract.

AND WHEREAS ..... contractors such Bank Guarantee.

NOW THEREFORE we hereby affirm that we are the Guarantor and responsible to you on behalf of the Contractor up to a total of .....(amount of guarantee)\* .....onwards, such sum being payable in the types and proportion of currencies which the contract price is payable and we undertake to pay you, upon your first written demand and without civil or argument, any sum or sums within the limits of ..... (amount of guarantee) as aforesaid without your needing to proof or to show grounds or reasons for your demand for the sum specified therein.

We hereby waive the necessity of your demanding the said debt from the contractor before presenting us with the demand.

We further agree that no change or addition to or other modification of the terms of the contract of the work to be performed there under or of any of the contract documents which may be made between you and the contractor shall in any way release us from any liability under this guarantee and hereby waive notification any such change, addition or modification.

Notwithstanding mentioned herein before our liability under this guarantee is restricted to Rs. .... (amount of guarantee) and this guarantee would be valid up to .....(date) and shall be discharged from all liabilities here under unless a written claim for payment under this guarantee is lodged with us within 2 months from the date of expiry of guarantee i.e. on or before .....(date), irrespective of whether or not the original guarantee is returned to us.

The confirmation of this guarantee is available with our controlling office at ..... The beneficiary in their own interest should obtain such confirmation from the controlling office at the above mentioned address enclosing a certified Xerox copy of the guarantee.

For .....

Senior Manager.

Signature and Stamp of the guarantor .....

Name of Bank .....

Address .....

Date .....

**\* An amount shall be inserted by the guarantor representing the percentage the contract price specified in the contract including additional security for unbalanced Bids, if any and denominated in Indian Rupees.**

**INDENTURE FOR SECURED ADVANCES**

**[Refer Clause 57.4 Section-3 of GCC]**

(for use in cases in which the contract is for finished work and the contractor has entered in to an agreement for the execution of a certain specified quantity of work in a given time).

This indenture made the ..... day of .....20.....  
BETWEEN ..... (hereinafter called the contractor which expression shall where the context so admits or implies be deemed to include his executors, administrator and assigns) or the one part and the Employer of the other part.

Whereas by an agreement dated ..... (hereinafter called the said agreement) the contractor has agreed.

AND WHEREAS the contractor has applied to the Employer that he may be allowed advanced on the security of materials absolutely belonging to him and brought by him to the site of the works the subject of the said agreement for use in the construction of such of the works as he has undertaken to executive at rates fixed for the finished work (inclusive of the cost of materials and labour and other charges).

AND WHEREAS the Employer has agreed to advance to the Contractor the sum of Rupees ..... on the security of materials the quantities and other particulars of which are detailed in Accounts of Secured Advances attached to the Running Account bill for the said works signed by the Contractor on ..... and the Employer has reserved to himself the option of making any further advance or advances on the security of other materials brought by the Contractor to the site of the said works.

Now THIS INDENTURE WITNESSETH that in pursuance of the said agreement and in consideration of the sum of Rupees ..... on or before the execution of these presents paid to the Contractor by the Employer (the receipt where of the Contractor both hereby acknowledge) and of such further advances (if any) as may be made to him as aforesaid the Contractor doth hereby covenant and agree with the President and declare as follows:

That the said sum of Rupees ..... so advanced by the Employer to the Contractor as aforesaid and all or any further sum of sums advanced as aforesaid shall be employed by the Contractor in or towards expending the execution of the said works and for no other purpose whatsoever.

That the materials details in the said Account of Secured Advances which have been offered to and accepted by the Employer a security are absolutely the Contractor's own propriety and free from encumbrances of any kind and the contractor will not make any application for or receive a further advance on the security of materials which are not absolutely his own property and free from encumbrances of any kind and the Contractor indemnified the Employer against all claims to any materials in respect of which an advances has be made to him as aforesaid.

That the materials detailed in the said account of Secured Advance and all other materials on the Security of which any further advance or advances may hereafter be made as aforesaid (hereinafter called the said materials) shall be used by the Contractors solely in the execution of the said works in accordance with the directions of the Engineer.

That the Contractor shall make at his own cost all necessary and adequate arrangements for the proper watch, safe custody and protection against all risks of the said materials and that until used in construction as aforesaid the said materials shall remain at the site of the said works in the Contractor's custody and on his own responsibility and shall at all times be open to inspection by the Engineer or any officer authorized by him. In the event of the said materials or any part thereof being stolen, destroyed or damaged or becoming deteriorated in a greater degree than is due to reasonable use and wear thereof the Contractor will forthwith replace the same with other materials of like quality or repair and make good the same required by the Engineer.

That the said materials shall not be any account be removed from the site of the said works except with the written permission of the Engineer or an officer authorized by him on that behalf.

That the advances shall be repayable in full when or before the Contractor receives payment from the Employer of the price payable to him for the said works under the terms and provisions of the said agreement. Provided that if any intermediate payments are made to the Contractor on account of work done than on the occasion of each such payment the Employer will be at liberty to make a recovery from the Contractor's bill for such payment by deducting there from the value of the said materials than actually used in the construction and in respect of which recovery has not been made previously, the value for this purpose being determined in respect of each description of materials at the rates at which the amounts of the advances made under these presents were calculated.

That if the Contractor shall at any time make any default in the performance or observance in any respect of any of the terms and provisions of the said agreement or of these presents the total amount of the advance or advances that may still be owing of the Employer shall immediately on the happening of such default be repayable by the Contractor to be the Employer together with interest thereon at twelve percent per annum from the date or respective dates of such advance or advance to the date of repayment and with all costs, charges, damages and expenses incurred by the Employer in or for the recovery thereof or the enforcement of this security or otherwise by reason of the default of the Contractor and the Contractor hereby covenants and agrees with the Employer to reply and pay the same respectively to him accordingly.

That the Contractor hereby charges all the said materials with the repayment to the Employer of the said sum of Rupees \_\_\_\_\_ and any further sum of sums advanced as aforesaid and all costs, charges, damage and expenses payable under these presents PROVIDED ALWAYS and it is hereby agreed and declared that notwithstanding anything in the said agreement and without prejudice to the power contained therein if and whenever the covenant for payment and repayment here-in-before contained shall become enforceable and the money owing shall not be paid in accordance there with the **Employer** may at any time thereafter adopt all or any of the following courses as he may deem best :

- (a) Seize and utilize the said materials or any part thereof in the completion of the said works on behalf of the contractor in accordance with the provisions in that behalf contained in the said agreement debiting the contractor with the actual cost of effecting such completion and the amount due to the contractor with the value of work done as if he had carried it out in accordance with the said agreement and at the rates thereby provided. If the balance is against the contractor, he is to pay same to the **Employer** on demand.

- (b) Remove and sell by public auction the seized materials or any part thereof and out of the moneys arising from the sale retain all the sums aforesaid repayable or payable to the Employer under these presents and pay over the surplus (if any) to the Contractor.
- (c) Deduct all or any part of the moneys owing out of the security deposit or any sum due to the Contractor under the said agreement.

That except in the event of such default on the part of the contractor as aforesaid interest on the said advance shall not be payable.

That in the event of any conflict between the provisions of these presents and the said agreement the provisions of these presents shall prevail and in the event of any dispute or difference arising over the construction or effect of these presents the settlement of which has not been here-in-before expressly provided for the same shall be referred to the Employer whose decision shall be final and the provision of the Indian Arbitration Act for the time being in force shall apply to any such reference.

For & On behalf of Contractor

**[Name:]**

**Designation**

Date:



**AGREEMENT**

**[Refer Clause 2.3 (a) Section-3 of GCC ]**

This agreement made on this ..... day of ....., 20...., between MUNICIPAL COMMISSIONER, NAGAR NIGAM DEHRADUN, a Corporation incorporated under the Companies Act, 1956 and having its Corporate Office at **Avasthapna Bhawan, Municipal Commissioner, Nagar Nigam, 583th, Opposite Govt. ITI Majra, Saharanpur Road, Dehradun.**(hereinafter referred to as ‘**Municipal Commissioner, Nagar Nigam Dehradun**’) which expression unless excluded by or repugnant to the context shall include their successors and assigns of the one part and M/s ..... (hereinafter referred to as ‘**Contractor**’) which expression, unless excluded by or repugnant to the context, shall include their successors and assigns of the other part.

Whereas the MUNICIPAL COMMISSIONER, NAGAR NIGAM DEHRADUN is desirous of ....., in accordance with the general requirements and conditions hereinafter appearing and whereas the contractor has agreed to provide the same.

NOW THEREFORE the parties here to hereby agrees as follows:

1. The following documents attached hereto shall be deemed to form an integral part of this Contract
  - a. NCB Document (Technical and Financial Bids).
  - b. The following appendices:-
    - Appendix A: Minutes of pre-bid meeting.
    - Appendix B: Copy of letter of acceptance.
    - Appendix C: Performance Guarantee in the form of Bank Guarantee

**"The contract is subject to the jurisdiction of Court at Dehradun only."**

In Witness where of the parties hereto have set their respective hands and seals in the day and the year first above written.

Signature and delivered by

Signed and delivery by

-----  
Contractor

-----  
For and on behalf of the Nigam

In presence of

1. -----

1. -----

2. -----

2. -----

**Letter of Acceptance**

**[Refer Clause 2.3 (b) Section-3 GCC]**

*(Letterhead paper of the Employer)*

To,  
.....  
.....

**Sub:** .....

**Ref:- Your tender dated .....**

**Sir,**

Your tender on Schedule-B will be quote item rate amount for the above noted work is hereby accepted on behalf of MD, MUNICIPAL COMMISSIONER, NAGAR NIGAM, Dehradun.

1. You are requested to submit Performance Guarantee and additional performance Guarantee of (Rs. .... only) within 14 days from issue of this letter. The Performance Guaranty shall be in the form of FDR/BG from any Scheduled / Nationalized bank in favour of Finance Controller, Nagar Nigam, Dehradun and shall be valid upto 60 days beyond the date of completion of the work.
2. On receipt of prescribed Performance Guaranty, necessary letter to commence the work shall be issued and site of work shall be handed over to you thereafter.

Yours sincerely,

For and on behalf of, Municipal Commissioner, Nagar  
Nigam

## Form of Bid-Securing Declaration

Date:

Bid No.:

To: *[insert complete name of Employer]*

We, the undersigned, declare that:

We understand that, according to your conditions, bids must be supported by a Bid-Securing Declaration.

We accept that we will automatically be suspended from being eligible for bidding in any contract with the entity that invited Bids for the period of time of *[insert number of months or years]* starting on *[insert date]*, if we are in breach of our obligation(s) under the bid conditions, because we:

- (a) have withdrawn our Bid during the period of Bid validity specified in the Section I. ITB Clause no. 16; or
- (b) having been notified of the acceptance of our Bid by the Employer during the period of bid validity, (i) fail or refuse to execute the Contract, if required, or (ii) fail or refuse to furnish the Performance Security and, if required, the Environmental and Social (ES) Performance Security, in accordance with Section I. ITB Clause no. 35.

We understand this Bid-Securing Declaration shall expire if we are not the successful Bidder, upon the earlier of (i) our receipt of your notification to us of the name of the successful Bidder; or (ii) forty-five days after the expiration of our Bid.

Name of the Bidder\* \_\_\_\_\_ *[insert complete name of person signing the Bid]*

Name of the person duly authorized to sign the Bid on behalf of the Bidder\*\* *[insert complete name of person duly authorized to sign the Bid]*

Title of the person signing the Bid *[insert complete title of the person signing the Bid]*

Signature of the person named above \_\_\_\_\_ *[insert signature of person whose name and capacity are shown above]*

Date signed *[insert date of signing]* day of *[insert month]*, *[insert year]*

\*: In the case of the Bid submitted by joint venture specify the name of the Joint Venture as Bidder

\*\* : Person signing the Bid shall have the power of attorney given by the Bidder to be attached with the Bid *[Note: In case of a Joint Venture, the Bid-Securing Declaration must be in the name of all members to the Joint Venture that submits the Bid.]*

# **Section-8**

# **Drawings**





## **SECTION – 06**

### **Bill Of Quantities**

## **BILL OF QUANTITIES**

### **Preamble**

- 1- The Bill of Quantities shall be read in conjunction with the instruction to Bidders, Conditions of Contract. Technical Specification and Drawings.
- 2- The quantities given in the Bill of Quantities are estimated and provisional, and are given to provide a common basis for bidding. The basis of payment will be the actual quantities of work ordered and carried out as measured by the contractor and verified by the Engineer, and valued at the rates and prices tendered in the priced Bill of Quantity, where applicable, and otherwise at such rates and prices as the Engineer may fix within the terms of the Contract.
- 3- The rates and prices tendered in the priced Bill of Quantities shall, except in so far as it is otherwise provide under the Contract, include all constructional plant, labour, supervision, material erection/ maintenance, insurance, profit, taxes and duties, together with all general risks, liabilities and obligations set out of implied in the contract.
- 4- The rates and price shall be quoted entirely in Indian Currency.
- 5- The whole cost of complying with the provision to the contract shall be included in the items provide in the priced Bill of Quantities, and where no items are provided the cost shall be deemed to be distributed among the rates and the prices entered for the related items of works.
- 6- General directions and description of work and materials are not necessarily repeated or summarized in the Bill of Quantities. References to the relevant sections of the contract documentations shall be made before entering rates of prices against each item in the Bill of Quantities.
- 7- The method of measurement of completed work for payment shall be in accordance with the specification for Buildings.
- 8- Errors will be corrected by the Employer for any arithmetic discrepancy as per clause Nos. 28 of the Instruction to Bidders.

Executive Engineer